

Product Installation Manual

TBM/L-1E

FOR:

TB222M/L、TB309-1M/L、

TB334M/L、TB336M/L、

TB340M/L、TB346M/L、

TB351M/L、TB353M/L、

TB354M/L、(N)TB131M/L、

(N)TB133-1M/L、(N)TB326M/L、

(N)TB347M/L、(N)TB352M/L

Product Installation Manual

Installation Instruction for water closet

Before Installing

FOR:
TB222M/L、TB309-1M/L、
TB334M/L、TB336M/L、
TB340M/L、TB346M/L、
TB351M/L、TB353M/L、
TB354M/L、(N)TB131M/L、
(N)TB133-1M/L、(N)TB326M/L、
(N)TB347M/L、(N)TB352M/L

1. Read the instruction carefully to be familiar with the tools, fittings and installation procedures to prevent any unnecessary damage.
2. Check the fittings follow the fitting form and check whether there is any damage of the product.
3. Check whether the roughing-in on installing position is aligned with the one of product. Realize all the stipulates for pipelines preposing for water supply.
4. Because the ceramics is easy to be damaged, please handle it gently and the nut should not be overtightened.
5. The floor of installation position should be flat and hard.
6. If you want to change the water closet, please turn off water supply and flush the water closet to make sure no water remains inside the product. Remove the soft pipe for water supply, and unfasten screws. Then remove the water closet and the old gasket and clean the end of the outlet of drainage.
Note: Please plug the drainage outlet on the floor if you do not install the product at once.
7. Make sure the water supply has been off.

NOTE: 1. Refer to the newest information of the printed matter. We reserve the rights to change the features, packing and fittings of the products without notice.
2. Please keep the installation instruction carefully (including installation procedure, fitting form, trouble shooting and notice.)

Tools and Fittings (Not supplied with the product)

- | | | |
|-----------------------|----------------|-------------------------|
| 1.monkey wrench | 5.level | 9.water supply valve |
| 2.pipe wrench | 6.screw driver | 10.connecting soft pipe |
| 3.tapeline | 7.hacksaw | 11.silicone |
| 4.percussive drilling | 8.sinker | 12.flange |

Installing Procedure

1. Install Flange and Water Supply Valve

1. Install the water supply valve onto the installing position according to the dimension of the product. Then get the flange aligned with drainage outlet. Mark the installing positions for screws and drill holes. Then fix the flange onto floor.

Note: Do not use high-congealed material (cement & mortar) when you installing the product because of the dilatation for the cement which will damage the bottom of product. EAGO has no responsibility for that damage.

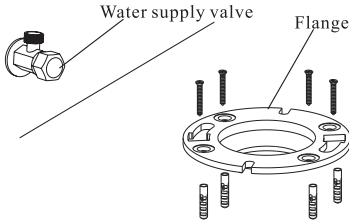

Mark installing holes

Mark the centre line for drainage outlet. Mark the installing position for mounting screws and connecting pipe as illustrated (drawing for distance of installing holes).

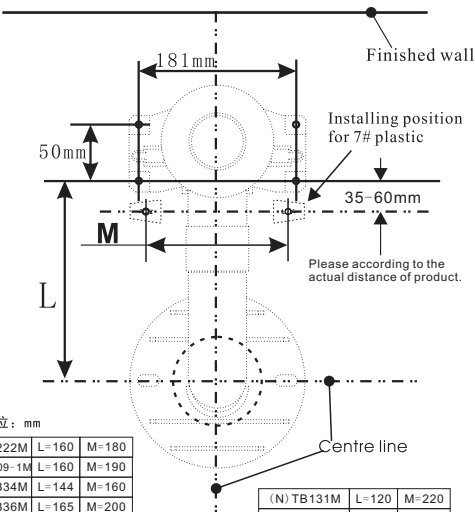
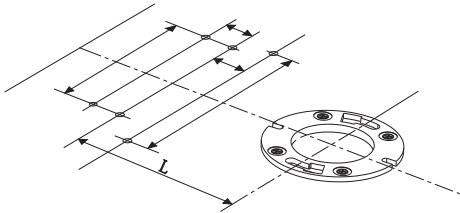

单位: mm

TB222M	L=160	M=180
TB309-1M	L=160	M=190
TB334M	L=144	M=180
TB336M	L=165	M=200
TB340M	L=160	M=190
TB346M	L=144	M=220
TB351M	L=130	M=220
TB353M	L=130	M=200
TB354M	L=130	M=200

(N) TB131M	L=120	M=220
(N) TB133-1M	L=144	M=210
(N) TB326M	L=135	M=190
(N) TB347M	L=130	M=190
(N) TB352M	L=130	M=210

Drawing for distance of installing holes

3. Install T# screw, mounting screw and connect pipe

- ① Drill holes onto installing position and insert expandable plastics.
- ② Make the bottom of connecting pipe up towards, then cover the flange onto water outlet tightly. Make sure the pipe is not plugged.
- ③ Get 2 T# screws through the installing holes of connecting pipe. Adjust the screws to get the four holes on the back side of connecting pipe aligned with expandable plastics on the floor. Fix the connecting pipe and 7# plastic onto the floor as illustrated.

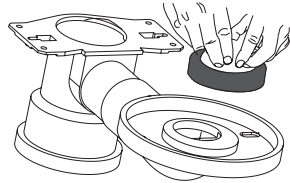

Installing Hole for Expandable Plastic 1: 4pcs
 Ø 5, height of 30mm
 Installing hole for Expandable Plastic 2: 2pcs
 Ø 10, height of 50mm

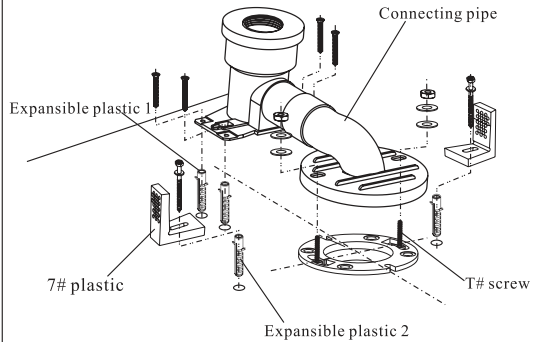

4. Install water closet

- ① Put up the water closet and make sure the two pieces of mounting screws are all through the installing holes of water closet. Get the centre line of water closet aligned with the centre line on the floor and then put down the water closet gently.

Note: Make sure the pipe is through the 4 layers of sealing rubber spacer of connecting pipe after installing the product. Otherwise it will have bad effect for flushing function.

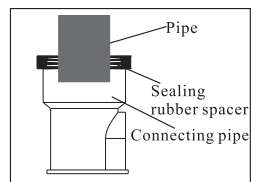
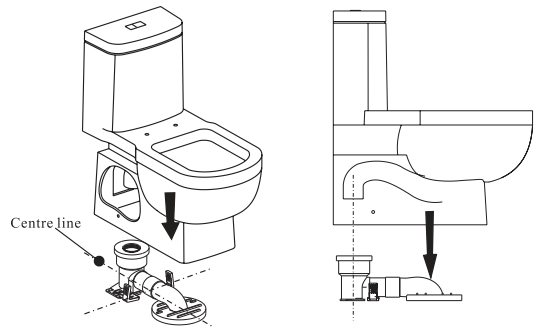

② Fix the product on the floor with screws and plastic covers, then cover the decoration caps.

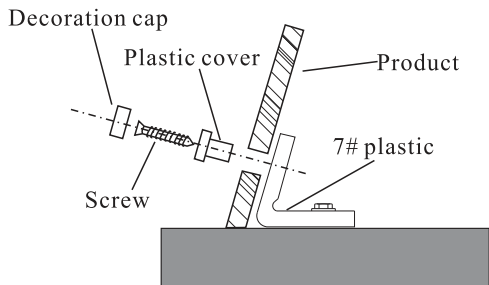

5. Connect water supply pipe and check sealing performance

Get the water supply pipe and the water inlet with soft connecting pipe. (If the fitting is separated filter, please connect filter first.) Turn on the water supply valve and make sure there is no leakage for every joint. Fasten the nuts a little can prevent leakage.

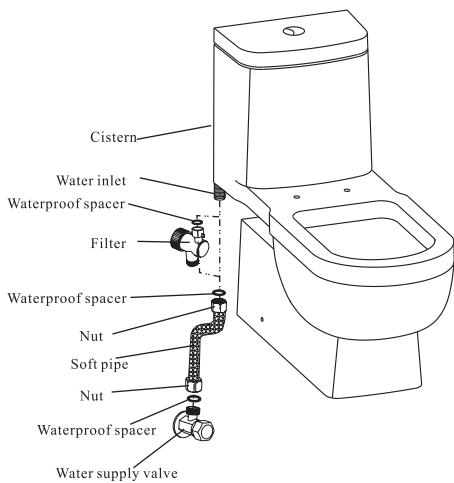

6. check Water refilling pipe

Open the cistern cover and make sure the overflow pipe is inserted into the water refilling pipe.

Note: If the water refilling pipe do not insert into the overflow pipe, the flushing water will be inadequate.

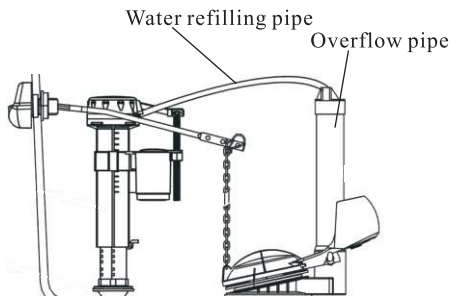

7. Install water closet seat

Install the water closet seat according to the installation instruction, then daub a layer of silicone between the product and floor.

Note: Do not use the product immediately after finishing installing. Make sure there is no water around the product about 24 hours.

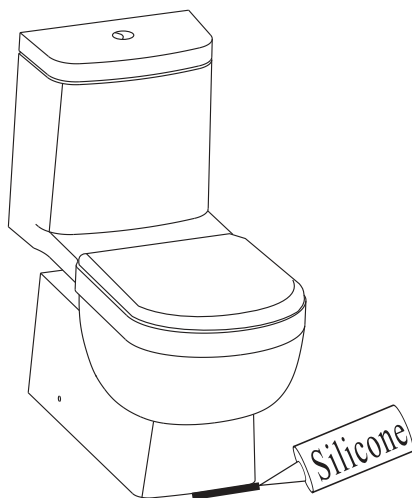

Troubleshooting

Malfunctions	Reason	Solutions
No incoming water	1.The main water valve does not open. 2.Incoming water filter net is clogged. 3.Floating ball of water inlet valve in cistern does not work.	1.Turn on the valve. 2.Clean the net. 3.Readjust the floating ball.
Non-stop incoming water	1.Higher water pressure. (The standard is 0.1-0.3MPa) 2.Floating ball of water inlet valve does not work. 3.Water inlet valve is broken. 4.Floating ball of water inlet valve touches the inwall of cistern.	1.Reduce water pressure. 2.Readjust the floating ball. 3.Call your dealer to replace a new inlet valve. 4.Adjust the direction of floating ball.
Inadequate flushing water	1.The water level of inlet valve is too low. 2.The push button does not reach pushing point. 3.Press the wrong button. (Dual Flush)	1.Adjust the water inlet valve to appropriate position. 2.Adjust water level rod. 3.Identify small and large flushing button or call you dealer.
Slow drainage (Inadequate suction)	1.The drainage outlet is not aligned with the outside drainage pipe. 2.Drainage pipes are obstructed. 3.Inadequate flushing water.	1.Readjust or reinstall the product. 2.Clean the drainage pipes. 3.Adjust the water in cistern.
Leakage	1.The hexangular nuts of water inlet valve are not fastened. 2.The water supply spacer of inlet valve is damaged. 3.The water supply spacer on the bottom of cistern is damaged.(Separate Water Closet)	1.Fasten the nuts. 2.Change the water supply spacers. 3.Change the water supply spacers.
Overflow from drainage pipe	1.Drainage pipes are obstructed. 2.Water outlet pipes are obstructed.	1.Clean the drainage pipes. 2.Clean the water outlet pipes.

Note:

1. Do not use the sitting we pan when the water temperature is 0℃below, please stop using it when the temperature is under 0 degree centi grade, and clean away the surplus water in it, otherwise the product will be damaged when the water icing and expanded.
2. Do not throw newspaper, paper diapers, sanitary napkins or other similar articles in the sitting we pan.
3. Do not impact the ceramic part heavily in case of any damage.
4. To keep the normal flushing function of sitting we pan, please use a long-handle nylon brush and a neutral cleanser to clean up the flushing hole or pipes, so as to prevent the accumulation of mineral substance. It is suggested to make cleaning once a week.
5. Clean up the filter once a month at least, so as to prevent slow water inletting or water blockage in the tank.
6. Do not use any cleanser in the tank; otherwise, the accessories (rubber) in the tank may be damaged,thus ,causing leakage or damage to the building.

Please follow what is specified below to avoid discoloration, deformation, craze or scratch on water closet seat.

1. Do not expose the water closet seats to sunlight, sources of heat and near the kitchen.
2. Do not use sharp edge or abrasive materials to clean water closet seats.
3. Do not use corrosive chemicals to clean water closet seats.
4. Do not put heavy or hard materials on water closet seats. Such as water closet tank or flowerpot.

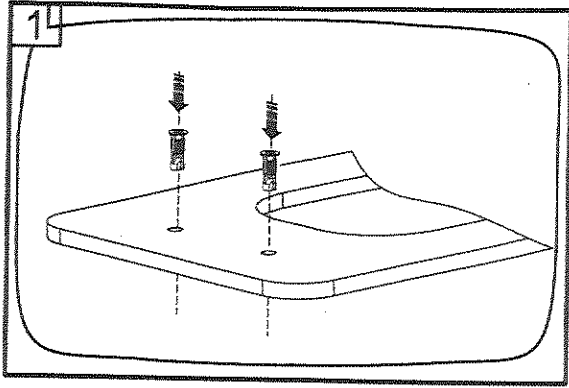

1
Insert the expansion rubbers into the hinge holes of the WC pan.

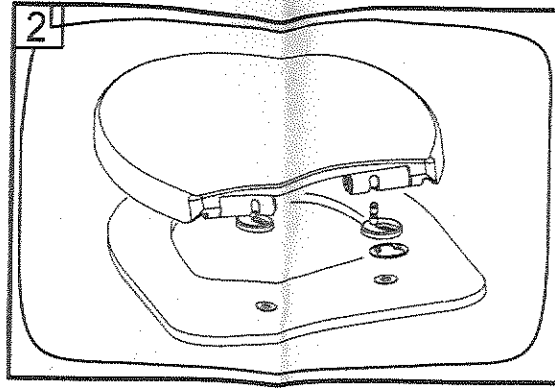

2
Mount the hinges onto the shaft of the toilet seats.

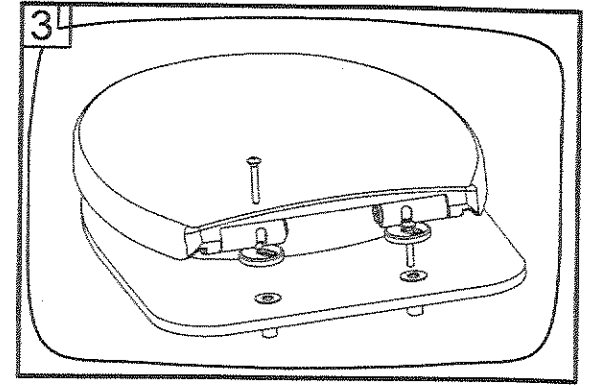

3
Plug the bolt into the expansion rubber.

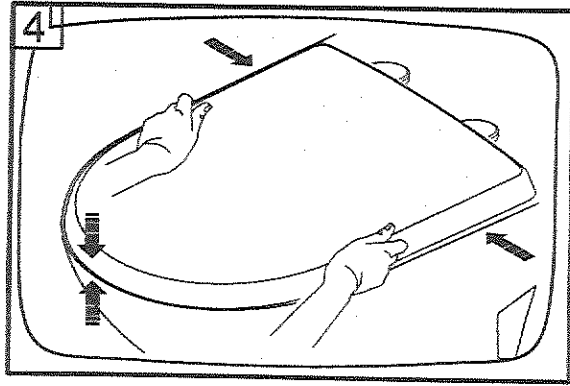

4
Align the toilet seats with the WC pan.

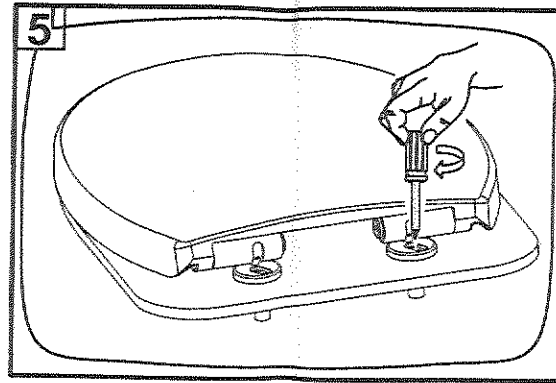

5
Screw the bolts.

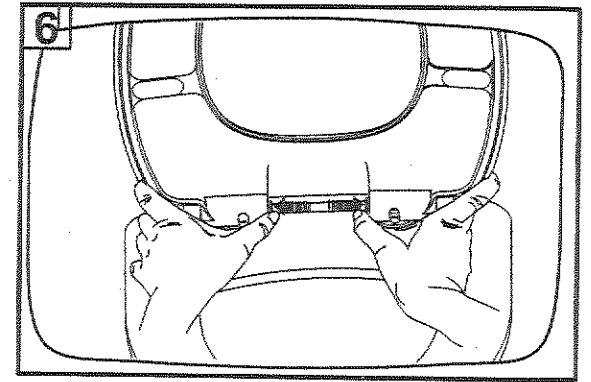

6
Push the right and left buttons.

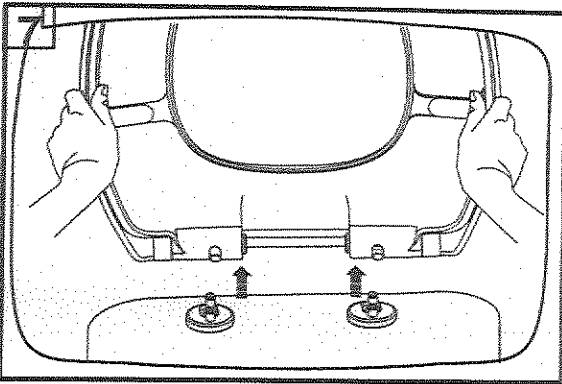

7
Lift the toilet seats.

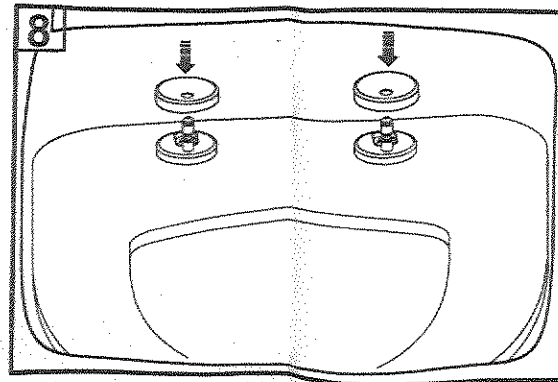

8
Put on the cover of the hinge.

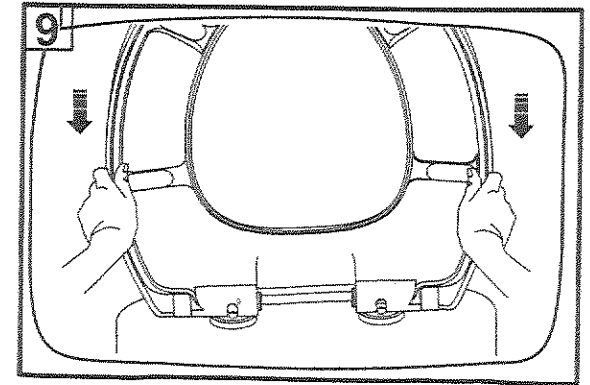

9
Mount the toilet seats.

Installation Manual of Tank Trims

Please give the manual to the end user. Please read the manual thoroughly before using it.

General Drawing

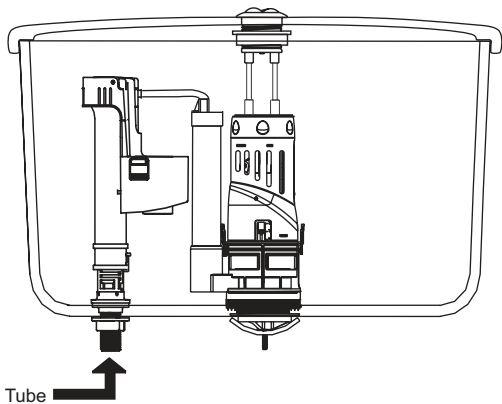

Connect Water supply Tube

WARNING:
Do not use an in-tank type bowl cleaner in your toilet. In-tank cleaners containing chlorine (calcium hypochlorite) can seriously damage fittings in the tank. We shall not be responsible for any tank fitting damage caused by the use of cleaners containing chlorine (calcium hypochlorite). We will not be liable for damages due to improper handling or installation, abuse or alteration of the product. We disclaim any responsibility for incidental or consequential damages.

The Installation Manual

1. The Installation of Fill Valve

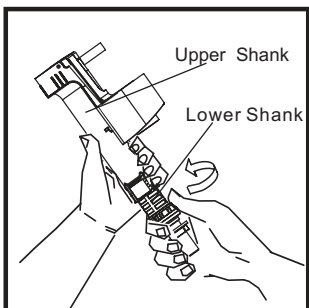

Adjust Height of Fill Valve:
To adjust height, push the Tamper proof up, turn the upper shank clockwise to unlock teeth from lower shank. Next, adjust the height by pulling up or down on upper shank to set at desired height.

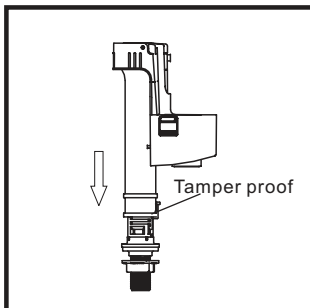

After adjusting height of Fill valve, rotate the upper shank counter clockwise to lock into lower shank. Next, push down On Tamper proof to secure it.

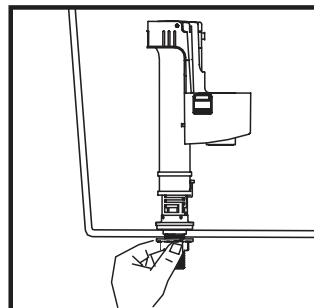

Installing Fill Valve: To install into tank, remove locknut and slide Fill Valve into the hole in tank. Next, position Fill valve to desired position and tighten the locknut. **(DO NOT OVER TIGHTEN)** (Torque <math>< 2.2 \text{ LB-FT}</math>)

2. The installation of Outlet Valve

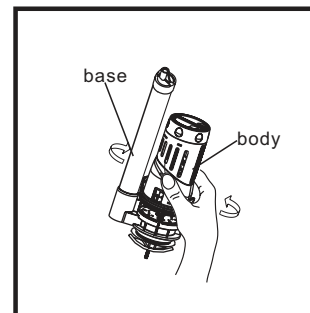

Rotate the flush valve body separate the body from base as shown in the Fig.

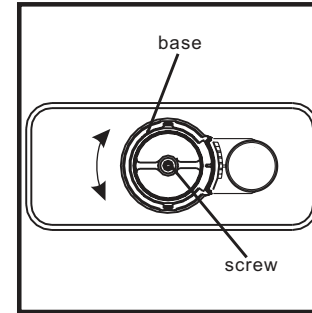

Install the flush valve base into the outlet to make the "U" clasp on the tank properly. Rotate the base to choose proper angle and lock the screw.

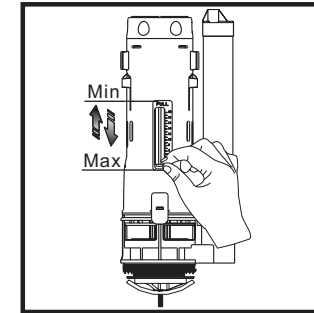

Adjustment of whole flush level: when the white card is on the highest position, the whole flush water is at the least.

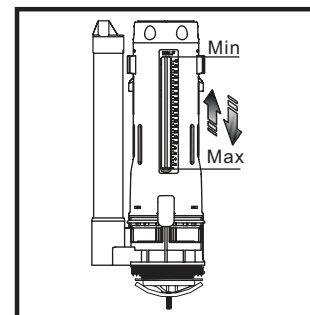

Adjustment of partial flush level: The partial flush float is higher, the partial flush water is less.

3. Push button installation

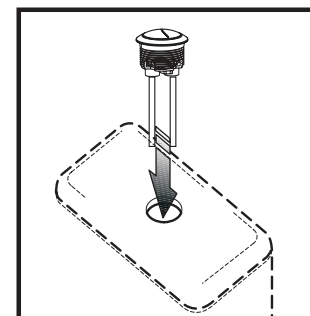

Cut the rod to a proper length, put the push button into the hole.

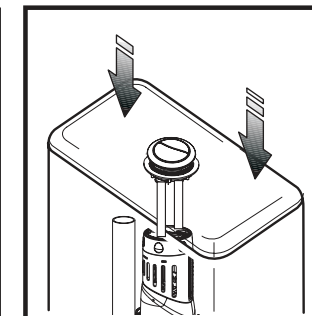

Adjust the direction of the push button. Be sure the full flush button toward the full flush touch piece.

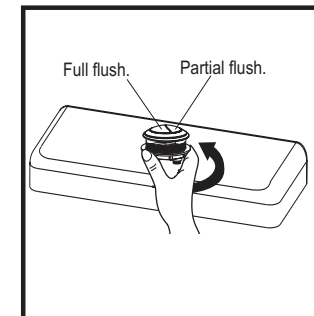

Tighten the nut.

Attention: If the product is different from the drawing, Please take the object as right.