

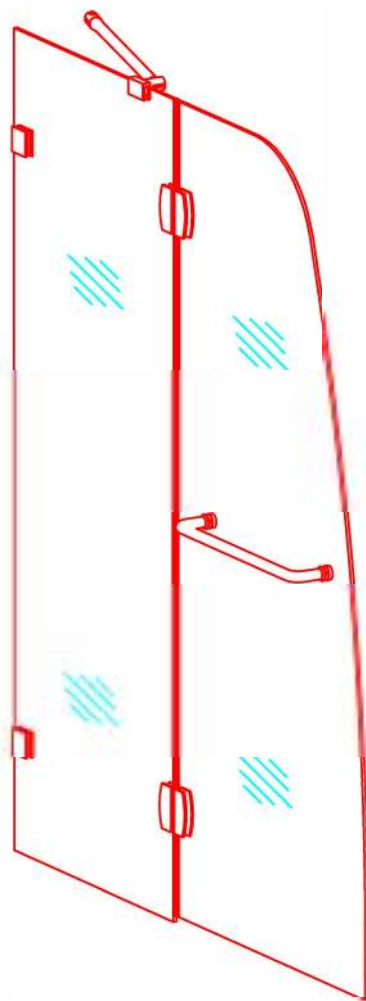

INSTALLATION AND OWNER'S MANUAL



SOLEIL TUB DOOR (TDR982)

Shower Door Model Number: TDR982.00

Please carefully read these instructions before you begin to install the products.

05/16 Rev C

P/N: SDR982.00

Before you start

Thank you for purchasing your Aston shower door. We hope that it will provide you with years of satisfying use and enjoyment.

Please read this manual carefully because it contains information and instructions about the proper installation of the unit. If you do not follow certain conditions of installation and maintenance, your warranty may be affected.

1. Inspect boxes for shipping damage. If the product has been damaged, is missing parts, or has a finishing defect, please contact our customer support department within 5 business days of delivery date.
2. NOTE: You should consult your local building codes with questions on installation compliance standards. Plumbing and building codes vary by location.
3. Before installation, inspect installation surfaces or level and have to the strength to support the heavy weight of this shower door assembly. This Shower Door should only be installed using the connection point to the studs or to pre-installed 2x6 wood reinforcements behind the wall.
4. This Shower Doors assembly is very heavy and requires professional installation.

Aston Shower door's feature:

- Tempered Safety Glass
- High quality hardware





WARNING: The Aston Shower door is designed to be used with tiled walls. If you are using a pre-made Acrylic/ABS/FRP shower stall that will be thicker than average plus tile, then you must consider the offset of the pre-made panel thickness.

Certifications:

All Aston Shower doors are 3rd party tested to meet the following US, Canadian and International Standards:

- CPSC 16 CFR1201 II / ANSI Z97.1 - 2009 Class A
- CSA B45 Series - 02

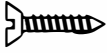
SUPPLIED HARDWARE

SCREW PACK (1)	M4x40		2
	Anchor		2
SCREW PACK (2)	M4x40		1
	Anchor		1

SUPPLIED PARTS

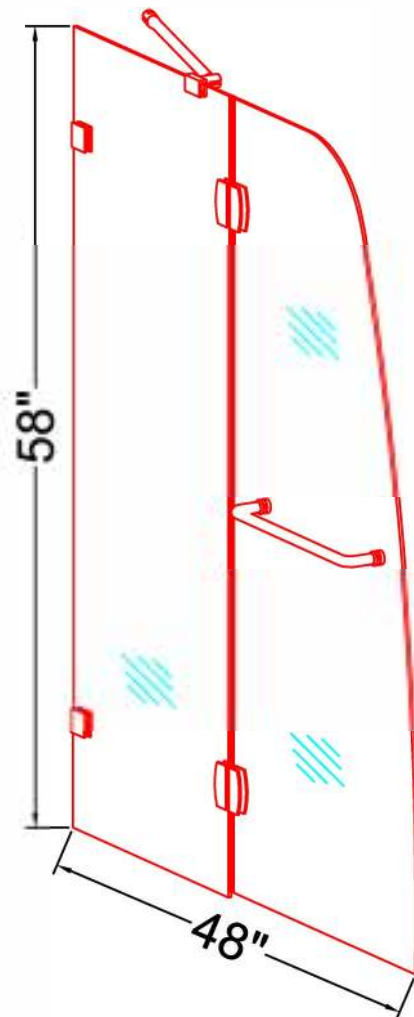

Detailed Diagram of Shower Door Components

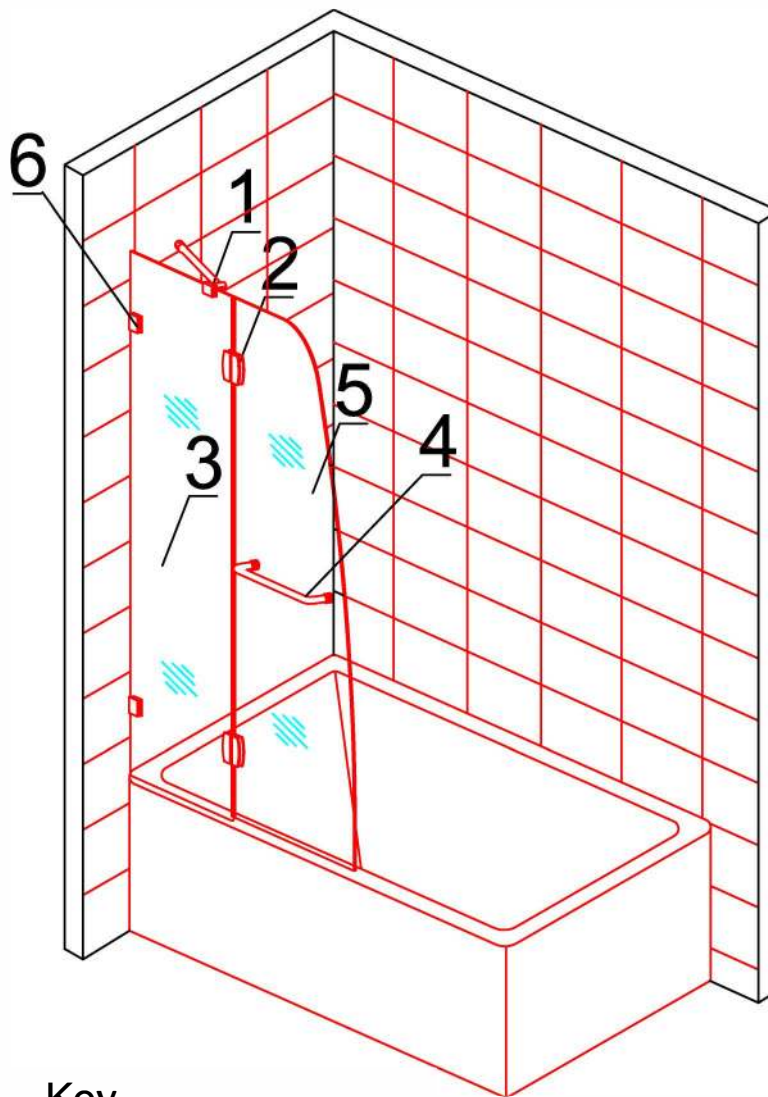

Key Number	Description	QTY
1	Glass Panel Support Rod	1
2	Door Hinge	2
3	Fixed Glass	1
4	Door Handle	1
5	Door	1
6	Glass Clamp	2

PLEASE NOTE: During unpacking carefully inspect all parts and use the exploded view drawing to identify all parts in the parts listing. Before discarding the packaging check for any parts or small hardware bags that may have been overlooked.

Installation Guide

Please read and follow the installation instructions and guidelines in this section. Failure to follow the recommended instructions and installation techniques may lead to possible damage to the unit or the surrounding area. This can affect warranty claims.

ATTENTION: This unit requires assembly. A minimum of two people are required for assembly, as several of the sections can be large and unstable until assembled.

You will need the following tools:

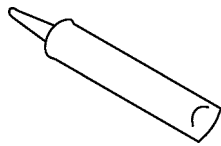

Caulk

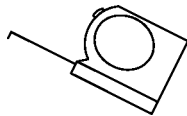

Tape Measure

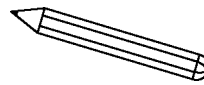

Pencil

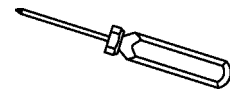

Phillips Screwdriver



Caulk Gun

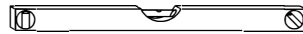

Level

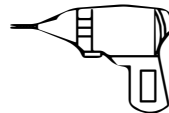

Electric Drill



Drill bit (Ø $\frac{5}{16}$ ")

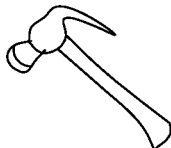

Hammer

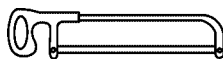

Hacksaw

Measure the glass clamp mounting holes of fixed glass panel

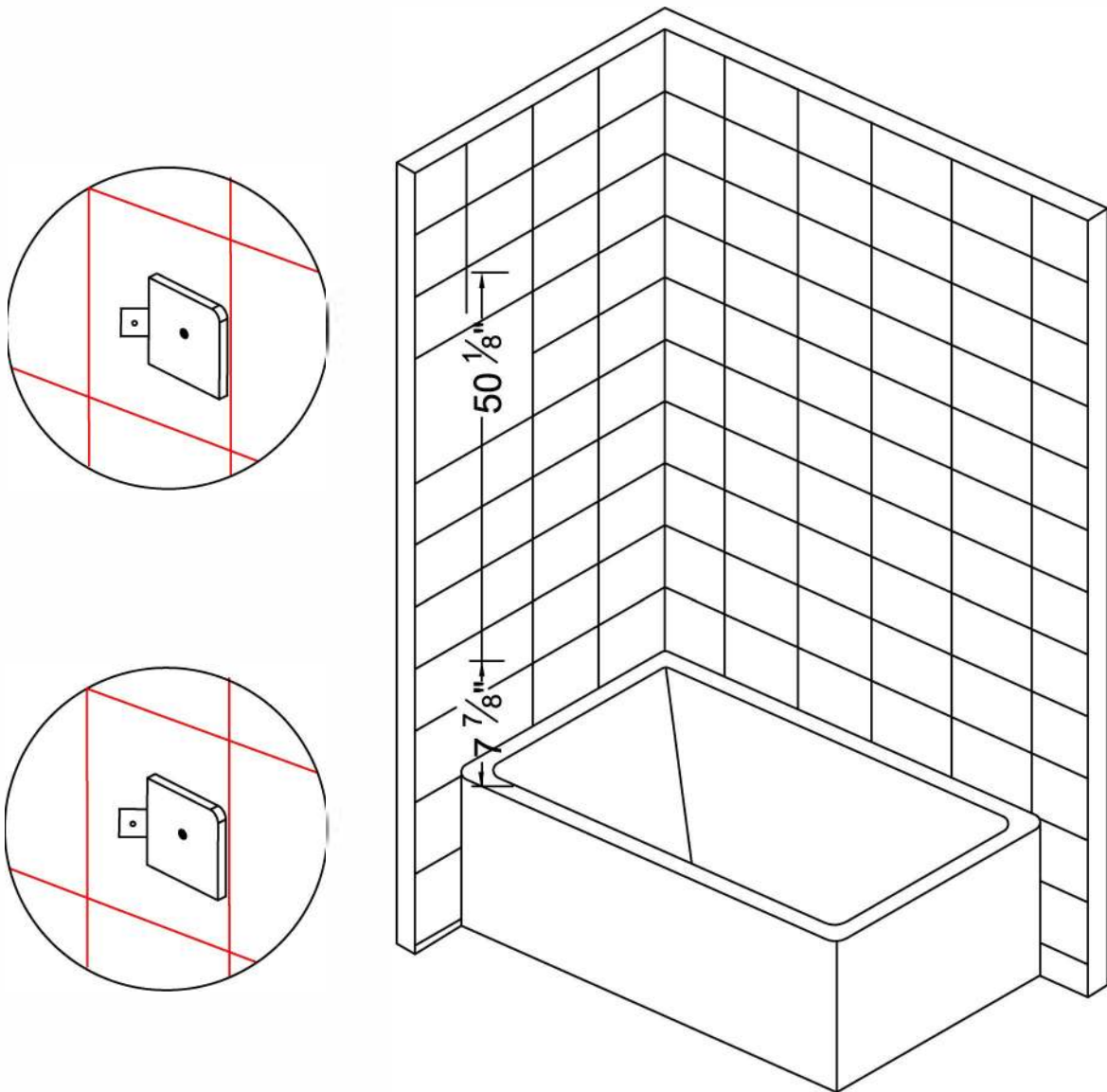

Install all of the wall material or materials you intend to use before installing the wall glass clamps this includes all moisture resistant wall board or rock board, tile, stone or other wall covering.

Refer to the drawing above and measure and mark the shower wall for drilling locations to attach glass clamps.

Install the glass clamp and fixed glass

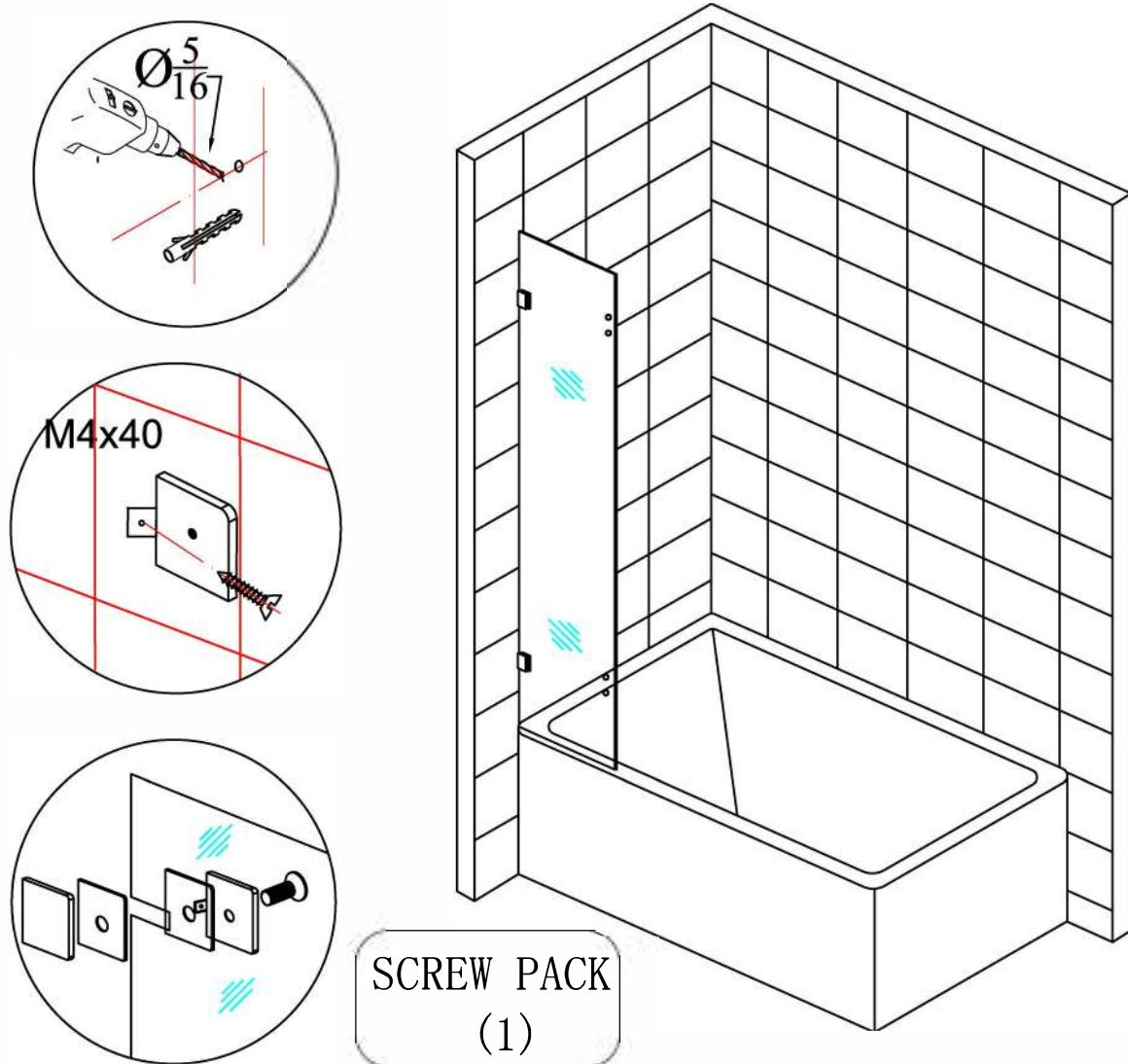

Using the appropriate drill bit for your wall surface drill each hole location with a 5/16" diameter drill bit. Install the plastic wall anchors provided into the drilled holes

NOTE: If your surface is prone to cracking or chipping then it is recommended that you pilot drill first using a smaller drill bit, and then step up to the final size.

Using screw pack (1) attach the glass clamp to wall using M4x40 screws. The glass clamp should be positioned so that single hole is facing toward the inside of shower.

Position fixed glass panel in tub and connect to glass clamps using hardware provided as seen in drawing.

Installing the support rod

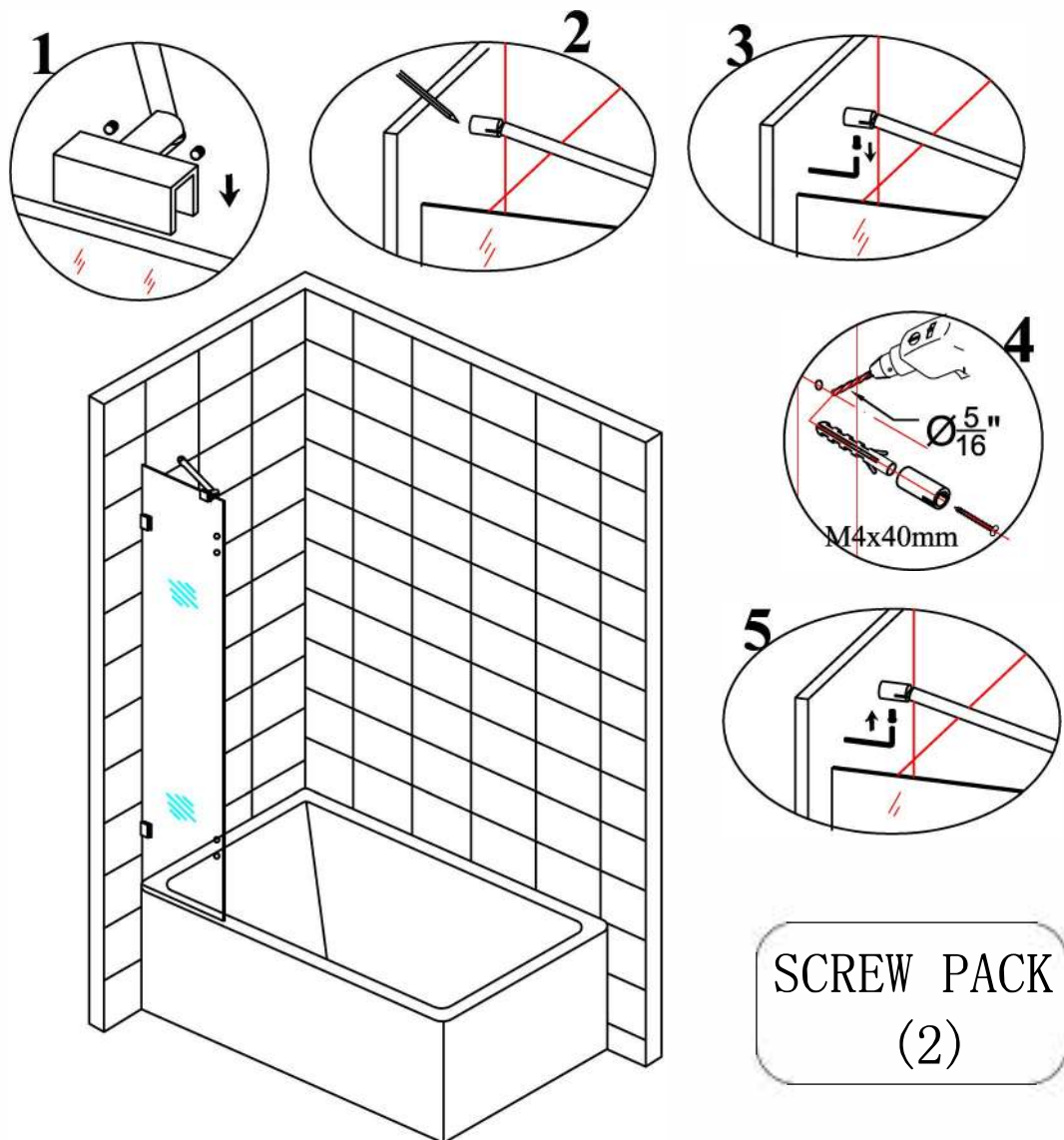

Pre-install the glass panel support rod and mark the mounting hole location on the shower wall. See figure 1 and figure 2.

Using the appropriate drill bit for your wall surface drill a single hole location with a 5/16" diameter drill bit. Install the plastic wall anchors provided into the drilled holes.

NOTE: If your surface is prone to cracking or chipping then it is recommended that you pilot drill first using a smaller drill bit, and then step up to the final size.

Mount the rod end on respective wall mounting location using the screw provided. Install the glass support rod using the hardware provided be sure to use the silicone washers between the glass and the hardware.

Installing the door

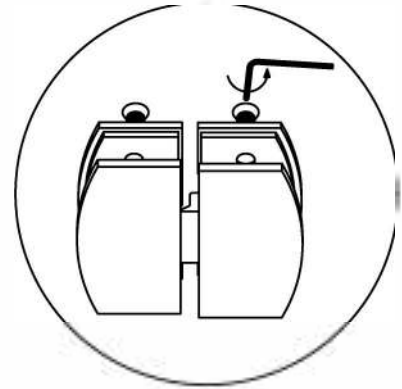
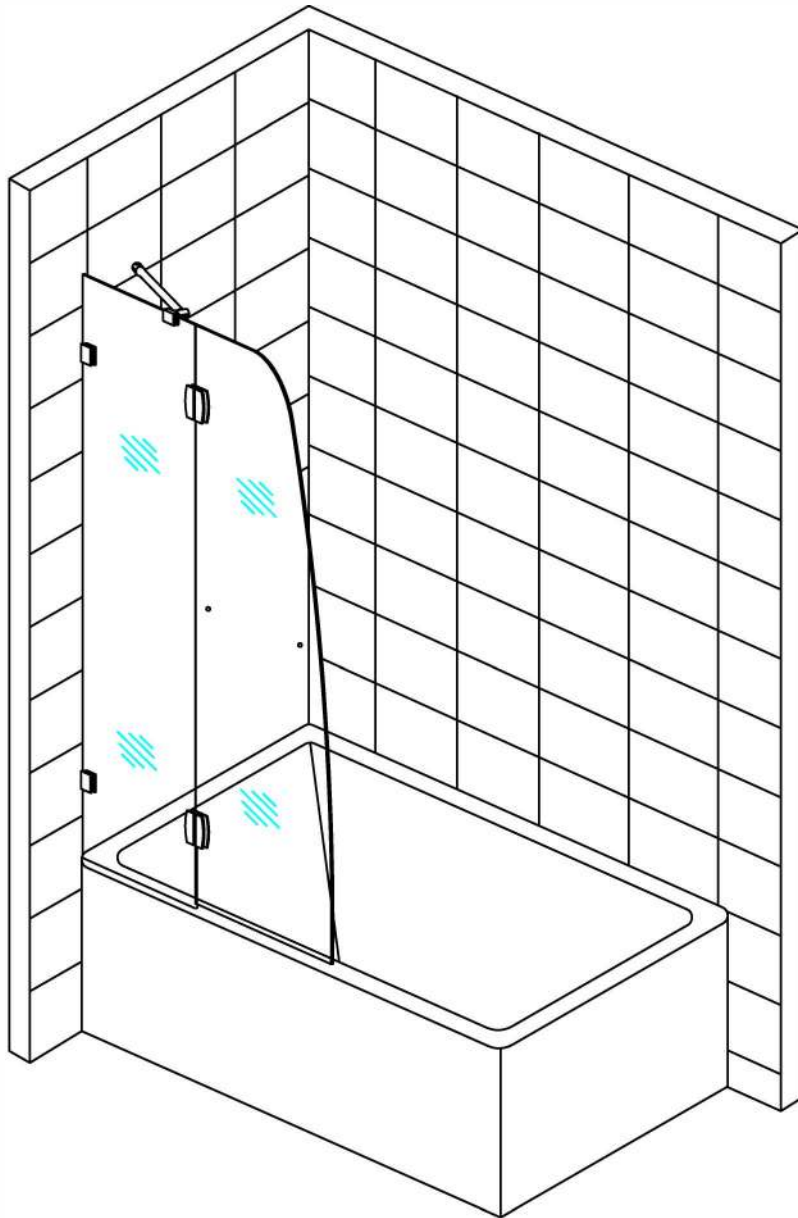

Note: This view is looking from inside of shower doors.

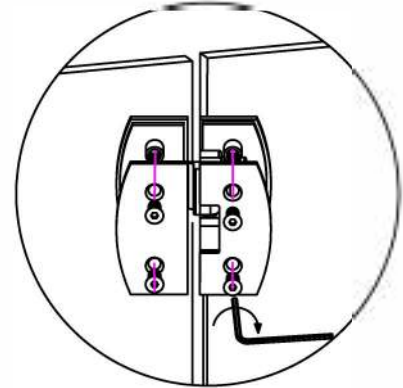

Position glass door in tub and connect to fixed glass panel using hinges provided as seen in drawing. Be sure to use the silicone washer provided between the glass and hinge to prevent scratching.

The hinges should be positioned so that screw holes are facing toward the inside of tub.

Installing the door seals

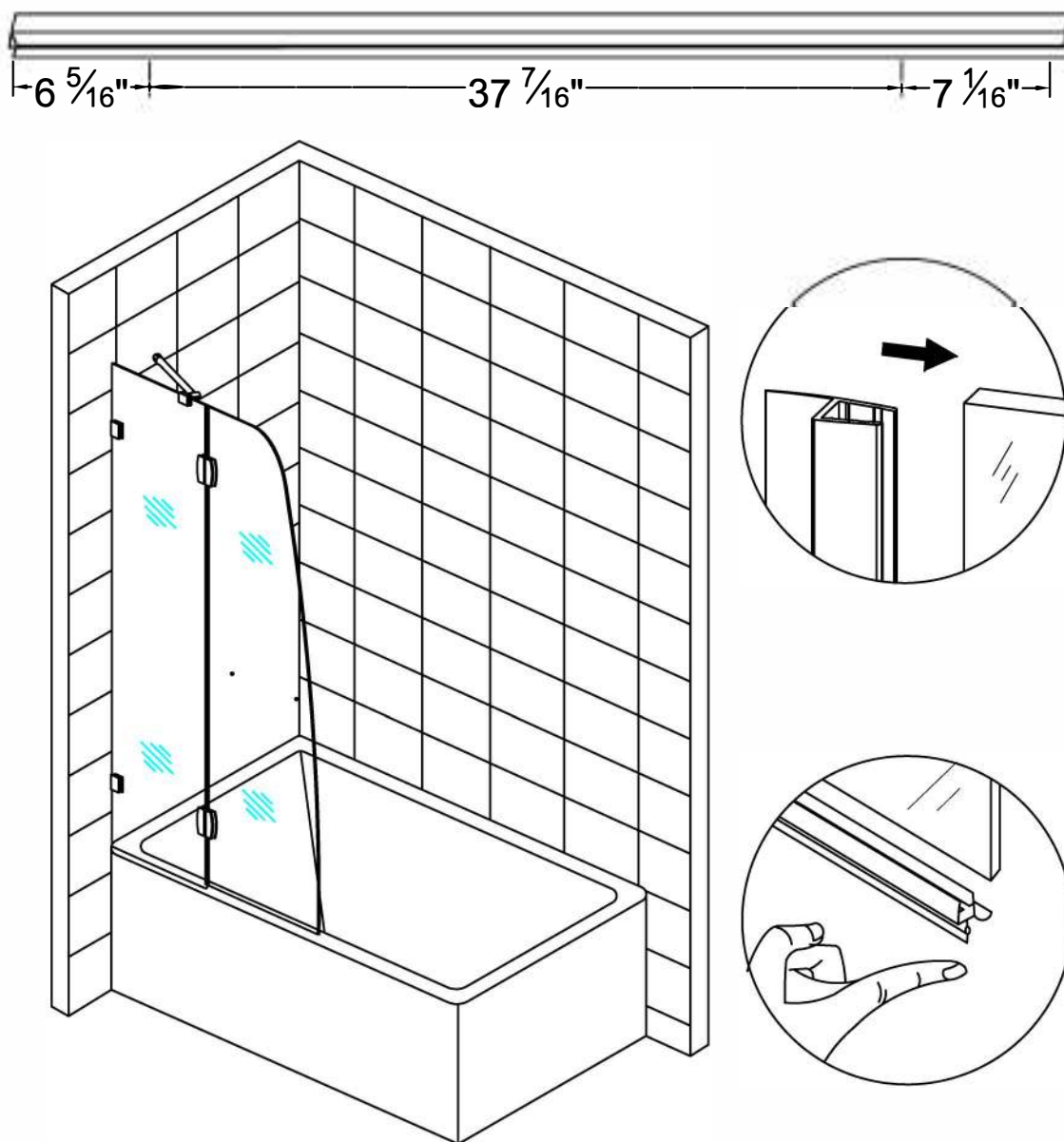

To install the vertical seal between the fixed panel and hinged door, you will need to cut the provided 58" long seal to properly seat in place. Make your marks on the seal at $6 \frac{5}{16}$ ", $37 \frac{7}{16}$ " and $7 \frac{1}{16}$ ". Carefully cut the seal at the appropriate marks, then install the individual seals on the appropriate sections of glass door.

Install the bottom seal on the door.

Once you have installed all of the seals close to the door and ensure a seal is created the entire length of the door. Make adjustments if necessary to the door to create a positive seal.

Installing the door handle

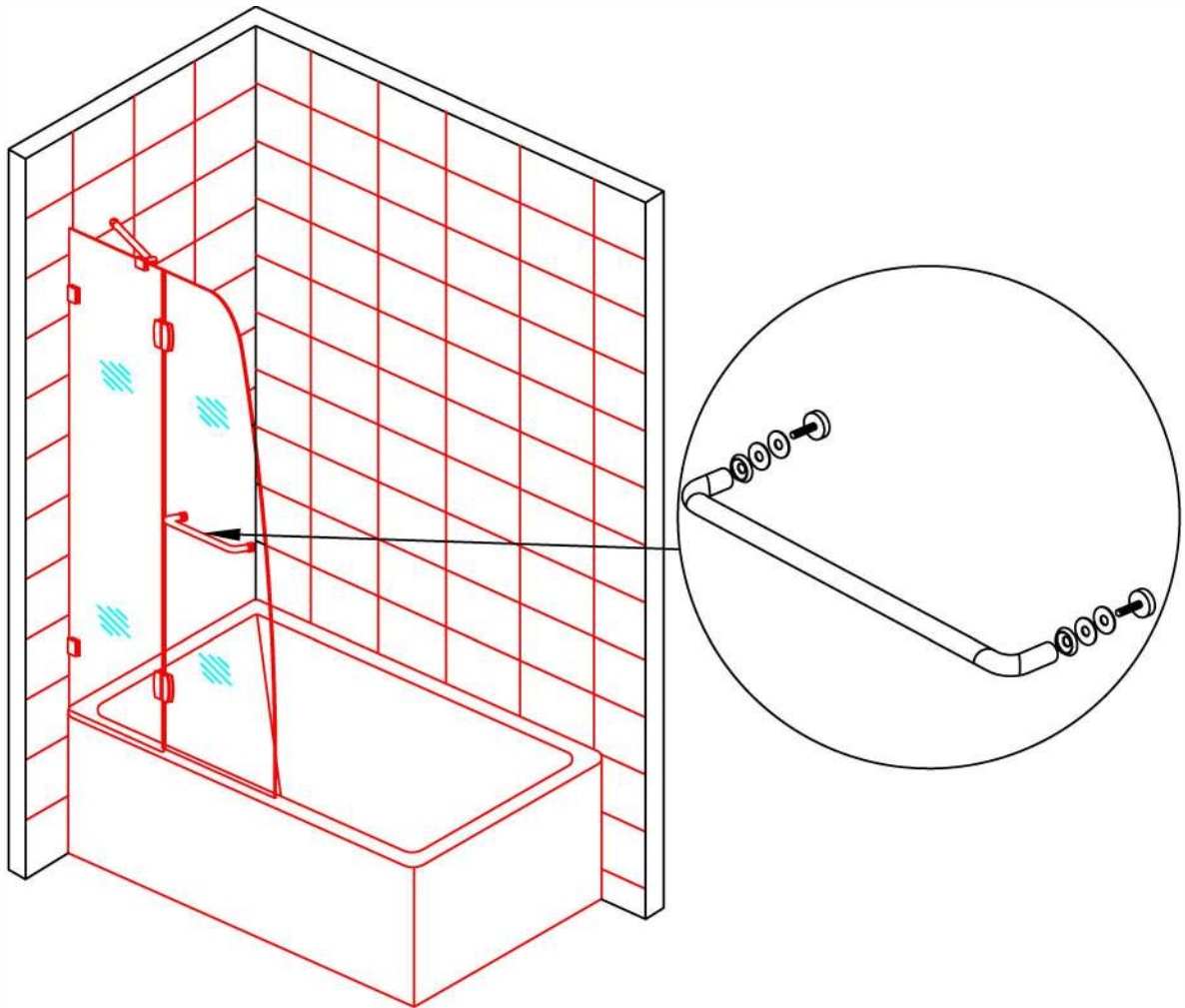

Install the door handle using the hardware provided be sure to use the silicone washer provided between the glass and the door handle to prevent scratching.

Care and Maintenance

As with any other luxury item, maintenance and care are critical to the long lasting quality and enjoyment of your shower door and tray. The proper care and maintenance outlined in this section are necessary to ensure the longevity of the unit. Damage caused by not following the care and maintenance guidelines in this section is not covered under the manufacturer's warranty.

The glass doors and panels can be cleaned using any commercially available glass cleaner.

We recommend that you clean the glass daily and squeegee the glass with a silicone or rubber squeegee after each use to help prevent water spots.

Warranty

PLEASE READ THESE WARRANTY TERMS AND CONDITIONS CAREFULLY BEFORE USING YOUR ASTON GLOBAL BATHROOM PRODUCT. BY USING THE PRODUCT, YOU ARE CONSENTING TO BE BOUND BY THE FOLLOWING WARRANTY TERMS AND CONDITIONS.

SHOWER DOOR/SHOWER TRAY

Aston Global Inc. Parts-Only Limited Warranty 5 years.

Warranty for any part in oil rubbed bronze finish is limited to two (2) years.

Aston Global, Inc. ("Aston Global") warrants to the original retail purchaser ("Owner") of any Shower Door/Tray product ("Product"), at the original installation site, for a period of Five (5) years from date of purchase (whether directly from Aston Global or an authorized reseller) that the Product manufactured by Aston Global is free from manufacturing defects in materials and workmanship, when used under normal conditions and when such Product has not been modified or changed in any manner after leaving Aston Global's warehouse or plant. If any Product manufactured by Aston Global is found to have manufacturing defects in materials or workmanship, such Product will be repaired or replaced by Aston Global. This warranty applies only against defects discovered within the warranty period and extends only to the original purchaser of the Product. Parts repaired or replaced under the terms of this Warranty will be warranted for the remainder of the original warranty period only.

Proof of purchase is required to exercise this Warranty. Aston Global may, at its option, examine and inspect the alleged defective Product, and Aston Global may request that parts be returned to Aston Global at Owner's expense for factory inspection. The determination as to whether Product shall be replaced, or in the alternative, repaired, shall be made solely by Aston Global. If a Product is determined to be covered by the above Warranty, Aston Global will ship the replacement part(s) to Customer by either ground shipping or US postal service. Increased costs for expedited delivery, if requested by Customer, are the responsibility of Customer. Parts not currently in stock may require up to a 6 week delivery time after placement of order.

The above warranty is subject to the following conditions: (1) the Product must be installed in a single family dwelling unit where the original purchaser of the Product resides; and (2) the Product must be maintained as described in the owner's manual supplied with the Product.

For glass and acrylic panels, the customer must (a) open and inspect the Product upon delivery (without releasing the delivery driver until visual verification that the Product arrived in a good and acceptable condition); and (b) clearly notate damage on the delivery acknowledgment receipt. Failure to do so, and any damage discovered to glass or acrylic panel after delivery, will be repaired or replaced at the sole discretion of Aston Global.

THIS WARRANTY DOES NOT COVER:

1. Product installed in buildings other than single family dwelling units.
2. Product installed outdoors or any other non-standard bathroom location.
3. Component parts not manufactured by Aston Global.
4. Workmanship of any installer of Aston Global Product. This warranty does not assume any liability of any nature for unsatisfactory performance caused by improper installation, or any damages to property resulting from improper installation or use of the Products, including but not limited to flooring, subfloor, tile, walls, sheet rock, concrete board, paint, plumbing fixtures and ceilings.
5. Labor costs incurred in the removal, disassembly, reassembly, or installation of the Product(s), including replacement Products issued under the Warranty, or costs for transportation to Aston Global, and any other materials necessary to return Product to Aston Global.
6. Any Product that has been damaged as a result of being improperly serviced or operated, including, but not limited to, the following: operated with insufficient water; allowed to freeze; subjected to flood conditions; operated with water conditions or additives which cause unusual deposits or corrosion in or on the Product, or subject to any other abuse or negligence.
7. Any Product that has been damaged as a result of natural disasters, including, but not limited to, lightning, fire, earthquake, hurricanes, tornadoes or floods.
8. Product used for any purpose other than residential bathroom usage.

LEGAL DISCLAIMERS

ALL IMPLIED WARRANTIES, INCLUDING WARRANTIES OF MERCHANTABILITY AND FITNESS FOR A PARTICULAR PURPOSE, ARE HEREBY DISCLAIMED IN THEIR ENTIRETY WITH RESPECT TO ALL PURCHASERS OR OWNERS. FAILURE TO RETURN THE WARRANTY CARD SHALL HAVE NO EFFECT ON THE DISCLAIMER OF THESE IMPLIED WARRANTIES. ALL EXPRESS WARRANTIES SHALL BE LIMITED TO THE DURATION OF THIS EXPRESS LIMITED WARRANTY AND EXCLUDE ANY LIABILITY FOR CONSEQUENTIAL OR INCIDENTAL DAMAGES RESULTING FROM THE BREACH OF ANY EXPRESS WARRANTY. Some states do not allow the exclusion or limitation of incidental or consequential damages, so the above limitations or exclusions may not apply. No dealer, distributor, service company or other party is authorized to change, modify or extend the terms of this warranty in any manner whatsoever.

Aston Global and its representatives shall not be liable for any injury, loss, cost or other damages, whether incidental or consequential, arising out of any defect covered by this Warranty including and without limitation, loss of use of the Product and cost for removal of defective Product, even if Aston Global has been advised of the possibility of such damage. The liability of Aston Global under this Warranty, if any, shall not exceed the original amount paid for the Product covered by the Warranty. Coverage under this Warranty shall commence as of the original date of purchase and the duration of such coverage shall not extend for any reason whatsoever beyond the stated time period. The

Customer is required to provide adequate access the Product for any repair or inspection. Aston Global shall not be liable for expenses or damage which may include but are limited to water damage, removal of any and all common building product such as tile, flooring, wood, sheet rock, plumbing fixtures, concrete board, vanities, bathtubs and toilets or any other custom items.

THIS WARRANTY GIVES YOU SPECIFIC LEGAL RIGHTS AND YOU MAY HAVE OTHER RIGHTS WHICH VARY FROM STATE TO STATE. ASTON GLOBAL'S FAILURE TO ENFORCE ANY TERMS OR CONDITIONS STATED HEREIN SHALL NOT BE CONSTRUED TO BE A WAIVER OF SUCH PROVISION.

For prompt service, notify the original installer who, in turn, will notify the Aston Global distributor who supplied the Product. If this does not result in prompt service, contact Aston Global, Inc. at the address below with details in support of the warranty claim. For any questions about coverage of this Warranty, contact Aston Global at the address below.

Aston Global offers free phone support for the life of the Product to the original Owner.

The Warranty applies only to Products manufactured on or after January 1, 2012.

This Warranty may not be combined with any other warranty offered by Aston Global.



Customer Service
877-424-9699

If further assistance is required, you have a question or need additional product information, please visit our website:

www.astonbath.com