

RELIANCE™ BATHS



OWNER'S MANUAL  
INSTALLATION GUIDE  
Effective July 1, 2011

Installer: This booklet must be given to the product owner.  
Please note important information below:

Distributor Name, City, State \_\_\_\_\_

Model # \_\_\_\_\_

Manufacturer's Date \_\_\_\_\_

Registration # \_\_\_\_\_

---

**Reliance™**

---

## OWNER'S MANUAL AND INSTALLATION GUIDE

Thank you for choosing a Reliance™ bath. You have purchased a high-quality acrylic bath, hand-crafted with pride in the USA. We know it will give you many years of pleasure. The instructions in this booklet will provide you with the information you need to install and operate this unit. This information is also available on our website: [reliancebaths.com](http://reliancebaths.com). Our customer service department is available to answer any additional questions you may have pertaining to the installation and operation of your bath. Call 800-783-8827 to speak to our Service Department. For faster service, please have your warranty registration number (serial number) ready when calling. The registration number can be found on the CSA/UL label adhered to the exterior surface of the tub. This sticker is typically placed on the exterior wall of the tub several inches above the pump.

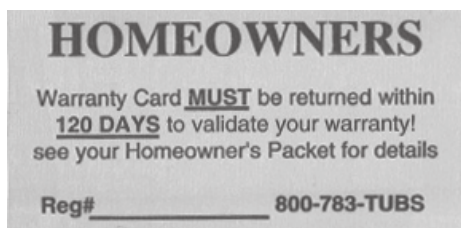

**IMPORTANT:** Locate and note your serial number on the cover of this manual for any future service needs.

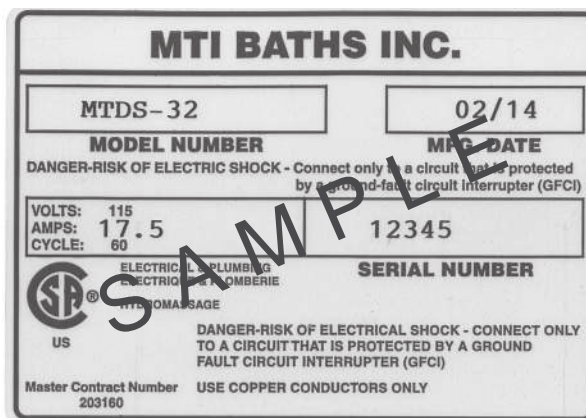

## IMPORTANT SAFETY INSTRUCTIONS

**WARNING - WHEN USING ELECTRICAL PRODUCTS, BASIC PRECAUTIONS SHOULD BE FOLLOWED, INCLUDING THE FOLLOWING:**

This manual contains information and instructions for proper operation and maintenance of your MTI bath. Failure to follow these instructions could result in personal injury, electrical shock or fire.

**INSTRUCTIONS PERTAINING TO RISK OF FIRE, ELECTRIC SHOCK, OR INJURY TO PERSONS.**

### READ AND FOLLOW ALL INSTRUCTIONS

- ⚠ Do not permit children to use this unit unless they are closely supervised by an adult at all times. Supervision is also required when bath is used by an elderly or handicapped individual.
- ⚠ Use this unit only for its intended use as described in this manual. Do not use attachments not recommended by the manufacturer. Never drop or insert any object into any opening.

- ⚠ Do not operate this unit without guard over the suction fitting.
- ⚠ The water in a whirlpool should never exceed 40° C (104° F). Water temperatures between 38° C (100° F) and 40° C (104° F) are considered safe for a healthy adult. Use time should be limited to approximately 10 minutes, followed by a shower to cool down. Longer exposures may result in hyperthermia, which can be fatal. The symptoms of this condition are nausea, dizziness and fainting. Lower water temperatures are recommended for extended use (exceeding 10 - 15 minutes) and for young children.
- ⚠ Since excessive water temperatures have a high potential for causing fetal damage during the early months of pregnancy, pregnant or possibly pregnant women should limit bath water temperatures to 38° C (100° F).
- ⚠ The use of drugs or alcoholic beverages before or during hydrotherapy bath use may lead to unconsciousness with the possibility of drowning. Never use the hydrotherapy bath while under the influence of alcohol, anticoagulants, stimulants, antihistamines, vasoconstrictors, vasodilators, hypnotics, narcotics or tranquilizers.
- ⚠ Persons with a medical history of heart disease, low or high blood pressure, circulatory system problems, or diabetes should consult a physician before using a hydrotherapy bath.
- ⚠ Persons using medication should consult a physician before using a hydrotherapy bath since medication may induce drowsiness, affect heart rate, blood pressure and circulation.
- ⚠ **DANGER:** To reduce the risk of injury, enter and exit the bath slowly.
- ⚠ **WARNING:** Never operate electrically connected devices in or within 5' of the bath. Never drop or insert any object into any opening within the hydrotherapy bath.
- ⚠ **DANGER:** Risk of electric shock. Connect only to circuits protected by a Ground Fault Circuit Interrupter (GFCI). Such a device should be installed by a licensed electrician and should be tested on a regular basis (at least monthly). To test the GFCI push the TEST button. The GFCI should interrupt the power. Push the RESET button and the power should be restored. If the GFCI fails to operate in this manner there is the possibility of an electric shock. **DO NOT USE.** Disconnect the unit and have the problem corrected by a qualified service technician. To avoid the possibility of personal injury and discoloration of the acrylic surface, the inlet water temperature should not exceed 60° C (140° F).
- ⚠ **DANGER:** Disconnect power before servicing.
- ⚠ A pressure wire connector is provided on the exterior of the pump or control within this unit to permit connection of a bonding conductor between this unit and all other exposed metal in the vicinity, as needed to comply with local requirements.

**INSTALLER/OWNER BEARS ALL RESPONSIBILITY TO COMPLY WITH ALL STATE AND LOCAL CODES WHEN INSTALLING THIS PRODUCT.**

- ⚠ **CAUTION:** Do not use harsh abrasives or solvents for cleaning this unit.

# SAVE THESE INSTRUCTIONS

## TABLE OF CONTENTS

Important Measurements .....	1
Installation Instructions .....	2-5
Electrical Installation Instructions .....	6
Important Safety Instructions.....	7
Operating Instructions .....	8
Cleaning Instructions.....	9
Troubleshooting.....	10-11
Residential Warranty .....	12-13
Commercial Warranty .....	14-15

---

## ATTENTION INSTALLER!

Access must be provided to each pump and/or electrical component on your tub. The access panel must have a minimum size of 16" x 14" for installation and future servicing of the equipment.

MTI Baths, Inc. will not authorize any service unless **clear** access is available. Access from a crawlspace or incomplete access to all equipment may result in warranty claims being denied.

---

# IMPORTANT INSTALLATION MEASUREMENTS

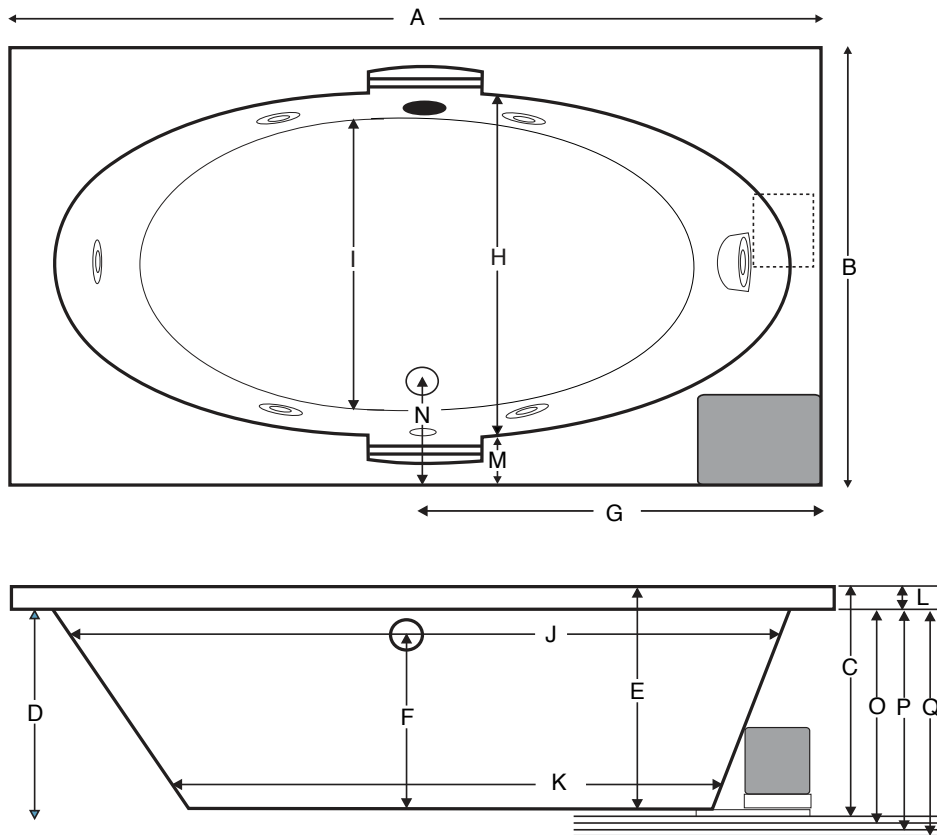

- A: Overall length
- B: Overall width
- C: Overall height
- D: Height — flange bottom to tub bottom
- E: Inside tub height
- F: Center of overflow to tub bottom
- G: Drain center to right tub edge
- H: Inside bowl width at top of bowl
- I: Inside bowl width at bottom of bowl
- J: Inside bowl length at top of bowl
- K: Inside bowl length at bottom of bowl

- L: Flange edge depth
- M: Top flange width
- N: Drain center to edge of flange
- O: Allow 1/2" to 1" to D for wet bedding
- P: Pre-leveled frame height\* – Adds 1/2" - 3" to height
- Q: Air bath height\* – Adds approximately 2" to height

\*Please measure actual tub **prior** to building any decking or framing. Specifications are subject to change without notice. MTI Baths is NOT responsible for any preparatory labor or materials.

# INSTALLATION INSTRUCTIONS

Read all instructions before installing tub.

## BEFORE INSTALLING:

Inspect tub thoroughly.

- A. Damage from shipping or delivery must be reported to carrier immediately. **Do not install damaged tub. MTI is not responsible for damage occurring in transit.**
- B. Factory defect must be reported to factory before tub is installed. Defects or damage claimed after installation will be excluded from warranty.
- C. **Important** - Measure tub on site carefully before framing or cutting any deck materials. Specifications are subject to change without notice. MTI Baths is NOT responsible for any preparatory labor or materials.

**WARNING: Certain cleaning products will permanently damage the acrylic surface. Read product label carefully before applying any cleaning product. Never use anything abrasive, aerosol sprays or any product that is described as "scrubbing bubbles".**

**CAUTION: DO NOT LIFT TUB BY PIPING OR PUMP  
DO NOT RUN PUMP DRY**

**To Do So May Cause Damage Not Covered By the Warranty**

*Never leave a full or filling bath unattended.*

## ATTENTION INSTALLER!

**THIS TUB MUST BE TESTED FOR OPERATION AND LEAKS PRIOR TO ENCLOSURE OF SURROUNDING AREAS. FAILURE TO DO SO WILL VOID WARRANTY. THIS TUB WAS WATER TESTED AT THE FACTORY AND FOUND TO BE FULLY OPERATIONAL AND LEAK FREE PRIOR TO SHIPPING. FREIGHT HANDLING AND JOB SITE EXPOSURE MAY HAVE DETERIORATED THE TUB'S CONDITION. IT IS THE RESPONSIBILITY OF THE INSTALLER TO THOROUGHLY TEST THE UNIT PRIOR TO INSTALLATION. TUBS ARE INTENDED, AND WARRANTIED, FOR INDOOR USE ONLY.**

### TEST PROCEDURES

1. Place the tub on a flat surface such as the driveway.
2. Seal the drain with tape.
3. Fill tub to overflow and allow tub to stand for five minutes **without the pump running**. Examine all fittings carefully for leaks. **NOTE:** The overflow is a plumbing device designed to prevent water from reaching a certain level in your tub. DO NOT, under any circumstances, tape off or block the overflow in any way. Any controls located above the normal water line are designed to be water-resistant, not water-proof. The controls will not leak under normal usage, however, they are not warranted against leaks when improperly used or subjected to conditions for which they were not designed.
4. Plug the pump, blower and/or in-line heater into a 110v GFCI outlet. Start the pump, blower and/or in-line heater, and check all fittings for leaks.
5. Check that all optional equipment is functioning properly and that the features on the tub match exactly what was ordered.
6. **If any leaks or operating problems are discovered, do not complete installation until problems are resolved. MTI will not be responsible for any costs involved with removing or reinstalling the tub, or for the costs of any surrounding materials.**

See troubleshooting section of this manual or call for assistance: 800-783-8827

**Always protect tub from construction damage by using a protective cover. Damage, including chips and scratches, incurred at the jobsite is excluded from warranty.** Do not store tub in temperatures below 32 degrees Fahrenheit. Proper waste and overflow installation is the responsibility of the installer. MTI does not warrant leaks associated with improper waste and overflow installation.

There are many possible ways to install your new Reliance tub, and some may require different framing than the following instructions. Keep in mind that the framing should always provide a level surface for the rim of the tub and sufficient space below the tub for bedding compound. **Access must be provided to each pump and/or electrical component on your tub. The access panels must have a minimum size of 16" x 14" for installation and future servicing of the pump and/or electrical equipment. MTI will not authorize any service unless clear access is available. Access from a crawlspace or incomplete access to all equipment may result in warranty claims being denied.** Additional access to plumbing fixtures is strongly recommended. It is the responsibility of the installer to comply with local plumbing codes regarding pump and plumbing access. **Note:** Do not allow any material such as insulation within 8" of pump. Pump must have sufficient air space surrounding it for circulation and proper operation.

## GENERAL INSTALLATION GUIDELINES

**Do not begin building any structure for your tub until your tub arrives. All printed specifications for Reliance tubs have +/- 1/2" tolerance AND ARE SUBJECT TO CHANGE AT ANY TIME. Take all final installation dimensions from your tub. Note: add approximately 2-3 inches to the overall tub height for drop-in tubs equipped with pre-leveled foam base and/or pre-leveled frame. The bolts/screws through the mounting feet on the pump may be loosened or removed once the tub is in place if necessary for future servicing.**

Reliance tubs are not equipped with leveling feet. The tub must be leveled from the top flange in both directions and bedding compound used underneath for proper operation. Determine the final height of the tub rim by measuring from the underside of the rim to the floor on the **drain side** and add 1/2" to allow for bedding compound. If your tub has a pre-leveled foam base, do not add 1/2" since wet-bedding is not necessary. The tub must be leveled by the rim of the tub, and supported by the bedding (or foam base) under the full length of the tub bottom. It is recommended to use a plastic sheet barrier on top of and underneath the bedding compound. Carefully lower tub into place. Shift tub side to side to settle into compound. The tub will not drain properly if not level both front to back and side to side. Use care not to damage any plumbing, wiring or other options when bedding the tub. Let compound harden overnight before use. Failure to properly bed the tub will void any warranty on the tub shell.

**NOTE:** Pre-leveled frame eliminates the need to frame the walls or use bedding compound to level the tub, assuming the floor is perfectly level. If not, some bedding compound may be needed to achieve level. **The pre-leveled frame adds 1/2 to 3 inches of height, depending on the specific model of tub.**

### ALCOVE

Mark a level line on the stud walls using the measurement determined above. A 2" x 2" or similar stringer will be attached to the studs touching this line. All mounting surfaces must be level to allow for proper drainage. Framing of the same height should be constructed across the front of the tub for skirt, tile or other material. Remember to allow for access to each pump, blower and/or electrical component.

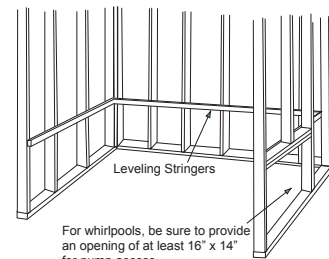

For whirlpools, be sure to provide an opening of at least 16" x 14" for pump access.

### DROP IN

Use the above dimension as the finished deck height from the floor. The drop in opening should be approximately 1 1/2 inches smaller than the outside dimensions of the tub. This will create a 3/4 inch ledge to support the entire rim of the tub. It is best to have as large an opening as possible in the deck to clear the plumbing and other tub accessories during install while still providing full support for the rim. Full size templates for oval tubs can be purchased through your distributor.

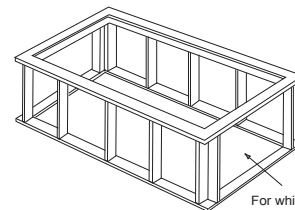

For whirlpools, be sure to provide an opening of at least 16" x 14" for pump access.

**NOTE: Most Reliance tubs are NOT undermountable. See individual tub specification sheets.**

**Have tub at jobsite and measure or template very carefully before cutting any decking materials. MTI is not responsible for any preparatory labor or materials.** If your application calls for solid surface material covering only the width of the tub flange, additional support for the solid surface material is not necessary.

*(continued on next page)*

## GENERAL INSTALLATION GUIDELINES *(continued from previous page)*

### PRE-LEVELLED FRAME

Place tub into proper location and attach to floor with 2" screws drilled through frame. This system does not require bedding compound unless subfloor is not level. A self leveling compound can be used to level the subfloor. Read and follow all manufacturers directions. The pre-leveled frame adds approximately 2"-3" to the height of the bath.

### WOOD SKIRT

Paint front and back of skirt to seal wood before attempting installation. Secure to floor cleat and wall supports using 4d finish nails. Paint as desired.

### TILE FLANGE – FACTORY INSTALLED

1. Mark flange of tub where it aligns with wall studs
2. Pre-drill a minimum of three holes on each side of the tub flange to align with selected wall studs. Place enough bedding compound (MTI recommends Quickrete Sand Mix) to fill void between the bottom of the tub and floor. **If your tub was ordered with the pre-leveled foam option, no bedding compound is necessary.** Note: If your floor is not completely level, use enough bedding compound to achieve level.
3. Work tub into bedding compound.
4. Ensure that tub is level, both front to back and side to side.
5. Attach tub to wall studs using the pre-drilled holes in the flange.
6. Fill the void between the tile flange and tub with clear silicone.



### TILE FLANGE KIT – FIELD INSTALLATION

1. Clean tub flange.
2. Apply supplied adhesive to tub flange and tile flange with brush, being careful not to get adhesive on top of tub.
3. Position tub 2-3" from wall.
4. Apply tile flange to tub flange.
5. Position the tub against the walls. Adhesive will set in five minutes.
6. Seal / fill the void between the tile flange and tub with clear silicone.
7. Trim any excess flange.

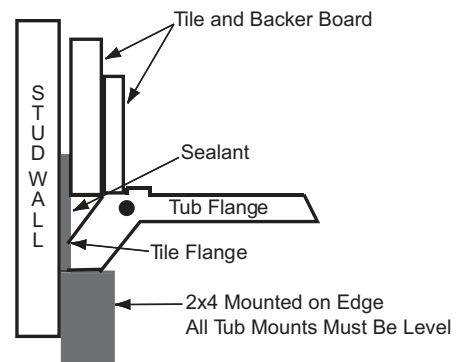

## INSTALLATION INSTRUCTIONS FOR AIR BATHS

**⚠ Do not attempt to remove the foam or board from the bottom of the tub. Doing so may cause damage and will void warranty.**

1. Never handle the bath by the blower, piping or other equipment.
2. Make sure the manifold and airlines are protected when moving the tub into the house.
3. An access panel of at least 16" x 14" must be provided for the blower for any future servicing.
4. The blower must not be insulated and must have sufficient air space to permit proper operation. Surrounding ambient air temperature should be between 72° F and 86° F.
5. The heating element on your blower heats the air blown into the tub to prevent the water from cooling too quickly. It will not, under any circumstances, reheat or maintain the temperature of the bath water.
6. The area underneath and around the tub must be cleaned thoroughly before finalizing installation to prevent any particles from entering the blower or being blown into the air jets.
7. Before filling the tub, clean installation debris and dirt from the interior of the tub. If necessary, use the soft brush attachment of a vacuum cleaner.
8. Fill tub and test for proper operation and leaks. Note: The blower must be plugged into a GFCI protected outlet.

**Note: All air baths are equipped with an automatic drying cycle. The blower will turn on for 1-2 minutes approximately 20 minutes after the air system is turned off. This drying cycle cannot be cancelled. Any attempt to cancel this cycle only resets the countdown timer.**

## INSTALLATION INSTRUCTIONS FOR INTEGRAL SKIRTED TUBS

All Reliance Integral Skirted tubs come with several standard features. Standard features include an integral molded front skirt, integral three-sided tile flange and a pre-leveled foam base. These tubs are designed to be installed in a three-wall alcove.

1. Slide tub into installation location. Check to ensure that the tub is level to allow for proper drainage. If the tub is not level, do not continued with the installation. A self leveling compound may be used to level the subfloor. Read and follow all manufacturers directions.
2. Carefully drill 1/8" holes through the tile flange at each stud location. Secure to stud with screws, being careful not to over-tighten as this might cause the acrylic to crack or chip. Do not attempt to drive nails through the integral flange. See *'Tile Flange - Factory Installed'* on previous page.

# ELECTRICAL INSTALLATION INSTRUCTIONS

**Warning:** When installing or using electrical products, basic precautions should always be followed, including:

1. All Reliance whirlpool and air baths require a separate 15 amp 110VAC circuit for each pump or air system blower. The inline heater for whirlpools adds 5.3 amps. The inline heater for air baths and soakers (HTISOAK) will require an additional 20 amp circuit. This circuit must be connected to a supply that is protected by a ground fault circuit interrupter (GFCI). Such a GFCI should be provided by the installer and tested on a routine basis. To test the GFCI, push the test button. The GFCI should interrupt power. Push the reset button. Power should be restored. If the GFCI fails to operate in this manner, there is a ground current flowing, indicating the possibility of electric shock. Do not use this unit. Disconnect the unit and have the problem corrected by a qualified electrician before using.
2. Every Reliance whirlpool or air bath is supplied with a 29" grounded plug on each pump, inline heater or air blower to be plugged into a standard grounded receptacle. Do not remove this plug. If a wall mount switch is desired to control use of the unit, the switch should control the receptacle. Under no circumstance should you alter the provided supply cord.
3. **A pressure wire connector is supplied on the exterior of the pump to permit connection of a No.8AWG (8.4mm) solid copper bonding conductor between this unit and all other electrical equipment and exposed metal in the vicinity as needed to comply with local requirements. NOTE: air blowers do not require a bonding conductor.**

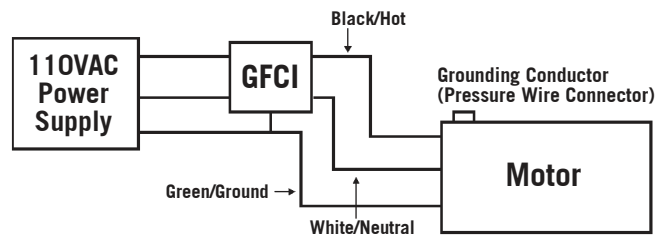

See Manufacturers Wiring Diagram on Motor

# IMPORTANT SAFETY INSTRUCTIONS

## Pertaining to a Risk of Fire, Electric Shock, or Injury to Persons

**WARNING:** When using electrical products, basic precautions should always be followed, including these: **(Please read and follow all directions. Save these instructions.)**

1. **DANGER:** To reduce the risk of injury, do not allow children or infirmed persons to use this product unless they are supervised at all times.
2. This Reliance hydrotherapy unit is designed for use only as described in this manual. Do not use attachments not recommended by the manufacturer.
3. Do not drop or insert any object into any opening.
4. Do not operate this tub without the guard over the suction fitting (water intake). The guard is a safety device that reduces the potential hazard of hair or body entrapment. Keep hair and body away from suction guard when pump is running.
5. Anyone under doctor's care, pregnant, or whose health is poor should check with a physician before using any whirlpool bath system.
6. Recommended length of hydrotherapy bath is 10 minutes. However, if you become dizzy or nauseous or develop a headache, get out at once and cool down. Get medical attention if symptoms persist. Also check with your physician before using this system again.
7. Do not use immediately after eating or while under the influence of drugs or alcohol.
8. Before servicing unit, shut off all electrical outlets as more than one outlet may be energized.

# WHIRLPOOL AND AIRBATH OPERATING INSTRUCTIONS

## WHIRLPOOL

1. Reliance whirlpool baths are equipped with a factory installed on/off device. This eliminates the need for an external switch, although one may have been provided by your installer. Check with your installer for location of switch. Starting motor with no water in the tub could result in damage to the pump and internal seals and could void your warranty.
2. Fill tub approximately 1" above highest jet. Do not start pump until tub has been filled to specified level.
3. When you are ready to use the hydrotherapy system, activate the on/off device on the deck of the tub.
4. Adjust the amount of air mixed with the water using the master air volume control located on the deck or sidewall of the tub. Rotate the control counter-clockwise to increase the amount of air and pressure in the system.
5. All jets on Reliance whirlpool baths are designed to operate individually. Open or close jets by twisting the outer ring.
6. Hydrotherapy jets can also be adjusted directionally.
7. Bath oils or other petroleum based products are not recommended for use in Reliance whirlpool baths. These products have been shown to increase the possibility of bacteria growth within the system.
8. Bubble bath should only be used sparingly. The action of the system will greatly increase the amount of bubbles. The system must also be cleaned after each use as described in "Cleaning Instructions."

## AIR BATH

1. Reliance air baths are equipped with a factory installed on/off device so an external switch is not required. Simply press the on/off button located on the tub to start the air blower.
2. The air blower has three speeds. The start up speed is high. Pressing the on/off button a second and third time activates the medium and low speeds respectively. The next press will turn the air blower off and activate the delayed purge cycle. The purge cycle will start 20 minutes after the blower is turned off and run for approximately 1-2 minutes. The purge system is designed to dry out the air jets and keep the system clean.

**NOTE:** The delayed automatic purge is only activated by turning the blower on and off. If the tub is frequently used as a shower or the air system is not used while bathing, it is recommended to manually purge the system. After using the tub, briefly turn the system on, then turn off. This will activate the 20 minute delayed purge cycle and keep the system clean and sanitary. Do not touch the on/off button during the purge cycle. Pressing the button will reset the cycle.

# CLEANING INSTRUCTIONS

## CLEANING INSTRUCTIONS FOR THE ACRYLIC SHELL

The cross-linked cast acrylic surface of all Reliance whirlpools, air baths and soaking baths is among the glossiest, highest quality surfaces available. Its hard, non-porous surface prevents dirt from accumulating and resists stains better than other materials. With normal use, cast acrylic will retain its beauty with only a minimal amount of care. To maintain the high gloss, elegant look of the cast acrylic surface, follow these simple steps:

1. Use common household, **non-abrasive** cleaners for most cleaning jobs (for example: a mild dishwashing detergent such as Ivory Liquid). Follow manufacturer's directions and precautions. Rinse well and dry with a soft, clean cloth. Be sure to check the product label. Some products, although not containing abrasives, WILL damage the acrylic over time.

***Never use any type of "scrubbing bubbles" on your acrylic product unless it specifically states that it is safe for use on acrylic!***

2. Never use abrasive cleansers. If any product feels gritty when rubbed between your fingers, do not use on the acrylic surface or controls as permanent damage will occur.
3. Do not allow your cast acrylic surface to come into contact with nail polish, nail polish remover, Wintergreen oil, dry cleaning solution, lacquer thinners, gasoline, pine oil, etc.
4. Remove dust and dry dirt with a soft, damp cloth.
5. Clean grease, oil, paint or ink stains with isopropyl (rubbing) alcohol. Dry with a clean, soft cloth.
6. Avoid using razor blades or other sharp objects that might scratch the surface. Small scratches can be removed by applying a thin coat of automotive paste wax and buffing lightly with a clean cloth. For deeper scratches, sand the surface lightly with a 400 grit "wet or dry" paper and buff with a fine grit buffing compound.

**MTI strongly recommends a professional acrylic repair person for deep scratches or chips.**

## CLEANING INSTRUCTIONS FOR WHIRLPOOL SYSTEMS

**THE WHIRLPOOL SYSTEM SHOULD BE CLEANED PERIODICALLY. IT IS RECOMMENDED TO CLEAN THE WHIRLPOOL PLUMBING SYSTEM AT LEAST ONCE A MONTH, NOT TO EXCEED 90 DAYS BETWEEN CLEANINGS. ALWAYS USE CAUTION WHEN USING CHLORINE-BASED PRODUCTS IN CONJUNCTION WITH OTHER CLEANING PRODUCTS. THE POSSIBILITY OF HARMFUL FUMES COULD RESULT. ALWAYS RINSE THOROUGHLY.**

Fill tub with warm water 2" above the highest jet and add **one** of the following to the bath water: 1 cup vinegar, **or** several drops of a low sudsing detergent mixed with 1 cup warm water. Turn the system on for five minutes then let stand for an additional 15 minutes. Drain the tub and refill with cold water. Restart the system for 10 minutes then drain.

## TROUBLESHOOTING Q & A

**Q: The pump or blower will not turn on. What should I check first?**

A: Check the electrical connections. Test the outlet for power by plugging in a small lamp or hair dryer. Check to make sure the breaker is not tripped. Replace GFCI outlet or breaker if necessary.

**Q: There is a leak at the pump when it's turned on. How do we stop the leak?**

A: Check the rubber "O" rings for proper seating. Tighten the large union nut rings on the pump. These may have loosened during shipping or installation. Do not over tighten.

**Q: The whirlpool jets do not seem to have much force. How can I adjust?**

A: Open the air volume control on the top or side wall of the tub to all for greater air flow through the jets.

**Q: One or two of my whirlpool jets are not working. What could be the problem?**

A: Each jet can be opened and closed individually. Check each jet by turning the jet escutcheon to ensure it's open.

**Q: How can I check that my in-line heater is working?**

A: The in-line heater has a separate power cord. Make sure the pump and heater are both plugged into working receptacles. The indicator light on the top of the heater will glow, indicating it is functioning properly. Keep in mind, the in-line heater will not heat your water; it will just maintain the water temperature up to 103 degrees.

**Q: There is a rust colored, greasy ring in my bath tub. What causes this?**

A: The condition results from sediment in the water heater of the home. Drain and flush the heater according to the manufacturer's instructions, and then clean the interior of the tub with a mild, grease cutting dish soap.

**Q: The air jets on my tub are not blowing air bubbles. What could be the problem?**

A: The on/off control may have been unplugged during installation. Check that the on/off control is connected to the blower, and the blower is plugged into a working receptacle. Check that the grey air hose from the air blower to the manifold is properly connected. If necessary, reconnect and tighten clamps.

**Q. My air bath appears to just turn on even if we are not in the tub.**

A. Each Reliance air bath is designed to purge 20 minutes after the system is turned off. This is normal, and helps keep the bath dry and sanitary.

**Q. I understand the purge cycle, however my tub is now purging in the middle of the night. How can I stop this from happening?**

A. Small, barely detectable power fluctuations may have disrupted the purge cycle. Turn the breaker off (or unplug the blower), wait for ten seconds, then plug back in. The blower should now follow the normal purge cycle.

**Q: The air bubbles seem cool. How do I check that the blower is warming the air?**

A: To verify, turn the air system on high for 4-5 minutes (you do not need to have water in the tub). Carefully feel the grey air hose where it exits the blower. It should be warm to the touch. If it is cold, please contact MTI for service. Please note that some skin sensitive people might experience the so-called "cold air effect", which is caused by the actual sensation of air bubbles running along the skin, giving the bather a "shivering" sensation. Note: Even if the air entering the tub was hot enough to burn the skin, this shivering effect would still persist. The heated blower is not designed to heat your bath water, just to preheat the incoming air.

If your tub is installed against an outside wall(s), it is recommended to adequately insulate the wall(s) to minimize heat loss. Do not insulate the blower itself; the blower needs sufficient air space surrounding it for proper circulation and operation.

**Q: Several of the air jets in my tub are not working. What could be the problem?**

A: Some of the air jets may be clogged from normal construction debris, possibly sheet rock dust. To correct: Fill the tub with several inches of warm water. Add 3-4 ounces of CLR. Use only the CLR in the yellow bottle, not the gray bottle. Allow to work for 30 minutes. Using a small brush, such as an old toothbrush, gently brush around each non-functioning jet. Caution! Do not turn the air system on while you have cleaning solution in the tub! Drain and rinse tub. Repeat if necessary.

**Q. Can I relocate the pump and/or blower?**

A. The whirlpool pump cannot be relocated once the tub is built. The air blower can be relocated on-site up to eight feet away from the bath.

**Q. Is it safe to use bath salts or bath oils in my whirlpool?**

A. Water soluble products such as bath salts are fine to use, however, MTI does not recommend the use of heavy bath oils. If bath oil is used, refer to the cleaning section of your manual for proper after care and cleaning instructions. Products containing strong natural or chemical dyes may discolor the jets and/or controls on your tub. Check the label to ensure the products are safe for acrylic or plastics, and always use according to the product recommendations.

**Q. How can I get scratches out of my acrylic tub?**

A. Most scratches can be buffed out using an automotive polish. Any polish suitable for use on "clear coated" automobile paint is fine. Deeper scratches and chips may require the services of a professional acrylic repair technician.

**Q. My bath's hydrotherapy system has been working great for years, and now has stopped working. What should I check first?**

A. The problem is most likely the breaker or the GFCI outlet under the tub. Check your breaker box first, and then use a hairdryer to test the outlet under your bath where the equipment is plugged in. This should identify the problem. If both these items check out fine, please have your registration number available and contact our technical service department.

**Q. How do I find the serial or registration number on my bath?**

A. The registration number can be found on a silver sticker attached to the outside wall of your bath. It is typically placed 3-4 inches over the pump and /or air blower.

## MTI RELIANCE™ RESIDENTIAL WARRANTY

This warranty is effective for all MTI Reliance™ bathtubs manufactured after January 1, 2008, and is in lieu of all other warranties.

MTI Baths (MTI) provides a limited warranty on its bathtubs for use in the continental United States of America to original purchasers for personal or single family use.

**Two-Year Warranty:** MTI warrants Reliance bathtubs for two years. The parts and labor warranty covers the tub shell and standard factory installed components, including pump, motor and standard plumbing, against defects in material or workmanship. All controls and mechanisms are subject to the MTI One-Year Parts Only warranty described below. The bath must be water tested for operation and leaks prior to final enclosure of the unit. Failure to do so will void warranty. If a problem is discovered after the final enclosure, MTI will not be responsible for the cost of removing or reinstalling the tub, or for the costs associated with any adjacent materials. Proper drain installation is the responsibility of the installer. MTI's warranty does not cover drain leakage.

**One-Year Parts Only Warranty:** MTI warrants all other components and options such as in-line heaters and on/off controls, not specified above for one year for parts only against defects in material or workmanship. Replacement parts are subject to availability, and may differ from those originally supplied. MTI can not guarantee that parts currently in use will be available in the future. Changes in materials, parts or specifications are not valid reasons for product refusal or replacement under warranty claims. Trim kits are specifically excluded from this warranty. MTI does not warrant valves and accessories. Check with MTI for details.

**Return of Warranty Card:** The Warranty Registration Card must be filled out by the purchaser within one hundred twenty days from purchase and mailed to MTI Baths in order for this warranty to become effective.

**MTI Baths is NOT liable for incidental or consequential damage, loss of time, inconvenience, incidental expenses, labor or material charges or any other costs related to the application of this warranty.**

**Warranty Limitations:** Your warranty is void if unit is not water tested and inspected prior to final enclosure. Our warranty does not cover defects, damage, or failure caused by common carrier, installer, user or other person. Chips, cracks and scratches can be repaired by a qualified technician at the owner/user's expense. We do not cover the following: careless handling; modification of any type for any reason; improper installation (See Installation Instructions); connections supplied by the installer; improper voltage supply/electrical modifications; misuse; incorrect or improper maintenance; incorrect or inadequate water use; use of improper cleaners; or extraordinary acts such as earthquakes, hurricanes, lightning, floods, hail, etc.

**Extent of Warranty:** This warranty extends only to the original consumer/ purchaser of the MTI Baths product when purchased and originally installed within the boundaries of the USA. The warranty terminates after transfer of ownership or if whirlpool is installed or relocated outside the boundaries of the USA by the original consumer/purchaser prior to the expiration of the warranty period. See commercial warranty for commercial installation coverage.

**Warranty Performance:** In the event of any malfunction or defect covered under the terms of this warranty, a Factory Authorized Service Agent of MTI Baths will repair the MTI product. To obtain service, contact the MTI Service Department for an agent in your area and issuance of a service order number. No work/payment will be made without an authorized service order number. There will be no charge for parts, labor or freight costs for parts necessary to repair the tub under warranty. Written notice of any malfunction or defect must be given within ten days of the time the malfunctions were discovered, and must be accompanied by the serial/registration number, tub model number and manufacturers date to verify purchase date. Notice must be given to: MTI Baths, 670 N. Price Rd., Sugar Hill, GA 30518, Attn: Service Dept. MTI reserves the right to inspect the malfunction or defect on site.

**Customer Service:** To verify coverage or request service, please contact the MTI service department at 800-783-8827 or email [info@reliancebaths.com](mailto:info@reliancebaths.com). Please have your serial or registration number available.

**Acts Invalidating Warranty:** Inspecting the unit prior to installation is the responsibility of the installer(s) or person(s) acting on behalf of the user. They are responsible for ensuring that the unit is free of defect or damage. Our shipping container advises the installer of this responsibility. MTI is not responsible for failure or damage that should have been discovered, repaired and avoided by proper inspection and testing prior to installation.

Damage that occurred in transit is the responsibility of the carrier. The user/installer must open and inspect the unit for damage when it is delivered.

It is the responsibility of the installer, contractor, or user to install/bed the unit properly allowing clear access for service. Unit must be water tested prior to final enclosure. Failure to do so will void warranty.

Damage occurring to the unit during installation is the responsibility of the installer, and after installation is the responsibility of the user.

**Disclaimers/Implied Warranty:** MTI Baths is not responsible for incidental or consequential damages/losses from any cause such as water damage to carpeting, floors or ceilings. Optional equipment not manufactured by MTI is not covered. Damages or defects that should be detected before installation are not covered. This limited warranty does not include labor, transportation or other costs incurred in the removal and/or reinstallation of the original unit or replacement unit. Costs related to obtaining access for repair are not covered.

The foregoing warranty is EXCLUSIVE and in lieu of all other warranties, including any other warranty of quality, express or implied, and including any warranty of merchantability, or any warranty of fitness for any particular purpose.

## MTI RELIANCE™ COMMERCIAL WARRANTY

This warranty is effective for all MTI Reliance™ bathtubs manufactured after January 1, 2008, and is in lieu of all other warranties.

MTI Baths (MTI) provides a limited warranty to the original purchaser for commercial, rental or multi-family applications. Bathtubs are warranted only when installed in a climate-controlled environment according to the instructions contained in our manual

**One-Year Warranty:** MTI warrants our Reliance bathtubs for one year. The parts and labor warranty covers the tub shell and standard factory installed components, including pump, motor and standard plumbing against defects in material or workmanship. All controls and mechanisms are subject to the MTI One-Year Parts only warranty described below. The bath must be water tested for operation and leaks prior to final enclosure of the unit. Failure to do so will void warranty. If a problem is discovered after the final enclosure, MTI will not be responsible for the cost of removing or reinstalling the tub, or for the costs associated with any adjacent materials. Proper drain installation is the responsibility of the installer. MTI's warranty does not cover drain leakage.

**One-Year Parts Only Warranty:** MTI warrants all other components and options such as in-line heaters and on/off controls, not specified above for one year for parts only against defects in material or workmanship. Replacement parts shall assume the remaining warranty period of the parts replaced. Replacement parts are subject to availability, and may differ from those originally supplied. MTI can not guarantee that parts currently in use will be available in the future. Changes in materials, parts or specifications are not valid reasons for product refusal or replacement under warranty claims. Trim kits are specifically excluded from this warranty. MTI does not warrant valves and accessories. Check with MTI for details.

**Return of Warranty Card:** The Warranty Registration Card must be filled out by the purchaser within 120 days from purchase and mailed to MTI Baths in order for this warranty to become effective.

**Warranty Limitations:** Your warranty is void if unit is not water tested and inspected prior to final enclosure. Our warranty does not cover defects, damage, or failure caused by common carrier, installer, user or other person. Chips, cracks and scratches can be repaired by a qualified technician at the owner/user's expense. We do not cover the following: careless handling; modification of any type for any reason; improper installation (See Installation Instructions); connections supplied by the installer; improper voltage supply/electrical modifications; misuse; incorrect or improper maintenance; incorrect or inadequate water use; use of improper cleaners; or extraordinary acts such as earthquakes, hurricanes, lightning, floods, hail, etc.

**MTI Baths is NOT liable for incidental or consequential damage, loss of time, inconvenience, incidental expenses, labor or material charges or any other costs related to the application of this warranty.**

**Extent of Warranty:** This warranty extends only to the original consumer/ purchaser of the MTI Baths product when purchased and originally installed within the boundaries of the USA. The warranty terminates after transfer of ownership or if whirlpool is installed or relocated outside the boundaries of the USA by the original consumer/purchaser prior to the expiration of the warranty period.

**Warranty Performance:** In the event of any malfunction or defect covered under the terms of this warranty, a Factory Authorized Service Agent of MTI Baths will repair the MTI product. To obtain service, contact the MTI Service Department for an agent in your area and issuance of a service order number. No work/payment will be made without an authorized service order number. There will be no charge for parts, labor or freight costs for parts necessary to repair the tub under warranty. Written notice of any malfunction or defect must be given within ten days of the time the malfunctions were discovered, and must be accompanied by the pump serial number, tub model number and manufacturers date to verify purchase date. Notice must be given to: MTI Baths, 670 N. Price Rd., Sugar Hill, GA 30518, Attn: Service Dept. MTI reserves the right to inspect the malfunction or defect on site.

**Customer Service:** To verify coverage or request service, please contact the MTI service department at 800-783-8827 or email [info@reliancebaths.com](mailto:info@reliancebaths.com). Please have your serial or registration number available.

**Acts Invalidating Warranty:** Inspecting the unit prior to installation is the responsibility of the installer(s) or person(s) acting on behalf of the user. They are responsible for ensuring that the unit is free of defect or damage. Our shipping container advises the installer of this responsibility. MTI is not responsible for failure or damage that should have been discovered, repaired and avoided by proper inspection and testing prior to installation.

Damage that occurred in transit is the responsibility of the carrier. The user/ installer must open and inspect the unit for damage when it is delivered.

It is the responsibility of the installer, contractor, or user to install/bed the unit properly allowing clear access for service. Unit must be water tested prior to final enclosure. Failure to do so will void warranty.

Damage occurring to the unit during installation is the responsibility of the installer, and after installation is the responsibility of the user.

**Disclaimers /Implied Warranty:** MTI Baths is not responsible for incidental or consequential damages/ losses from any cause such as water damage to carpeting, floors or ceilings. Optional equipment not manufactured by MTI is not covered. Damages or defects that should be detected before installation are not covered. This limited warranty does not include labor, transportation or other costs incurred in the removal and/or reinstallation of the original unit or replacement unit. Costs related to obtaining access for repair are not covered.

The foregoing warranty is EXCLUSIVE and in lieu of all other warranties, including any other warranty of quality, express or implied, and including any warranty of merchantability, or any warranty of fitness for any particular purpose.



Manufactured by: MTI Baths, Inc.  
670 N. Price Road  
Sugar Hill, GA 30518  
800 783 8827  
770 271 8228  
Fax 800 438 8827  
[reliancebaths.com](http://reliancebaths.com)

Email: [info@reliancebaths.com](mailto:info@reliancebaths.com)

© Copyright 2014 by MTI Whirlpools, Inc.  
Modification Rights Reserved.

1114

Part # RELTUB

---

**Reliance**<sup>™</sup>

---