

PS-006

FEATURES:

- * Sink Size: 24" x 17 1/2" x 5 1/2"
- * Material: Ceramic
- * Finish: Semi gloss
- * Above counter sink
- * With overflow
- * Warranty: 2 Year Limited Warranty

CODES / STANDARDS APPLICABLE

- * CSA B45
- * ASME A112.19.2

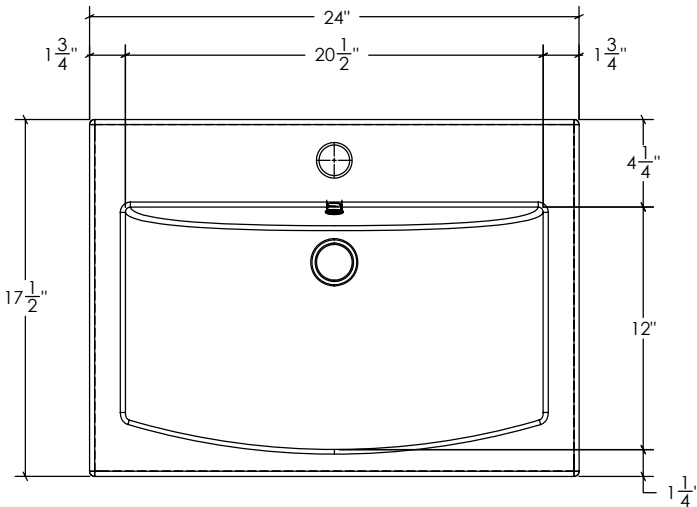

TOP VIEW

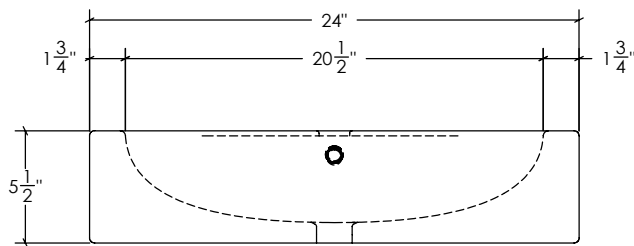
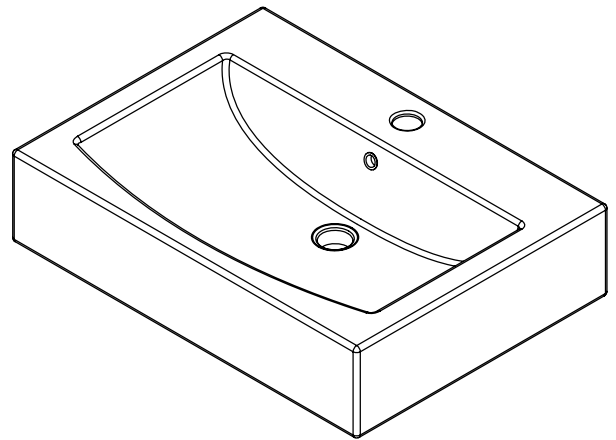

FRONT VIEW

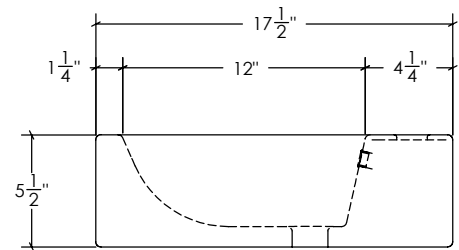

SIDE VIEW

JOB INFORMATION:

Job Name _____
 Date Specified _____
 Contractor _____

* Specifications and drawings provided on this sheet are for illustration only. Cantrio Concepts will not be held responsible for cutouts made without the actual product or product template.