

MS-2318

FEATURES:

- * Sink Size: 22-7/8" x 16-3/8" x 4-3/8"
- * Material: Stainless Steel with mirror Finish
- * Handmade Undermount 10mm Radius Sink
- * For Use With Standard Pop Up Drain
- * Limited Lifetime Warranty

CODES / STANDARDS APPLICABLE

- * CSA B45
- * ASME A112.19.2

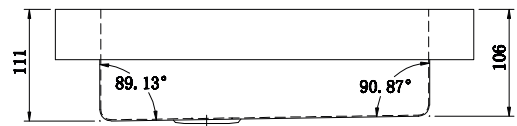
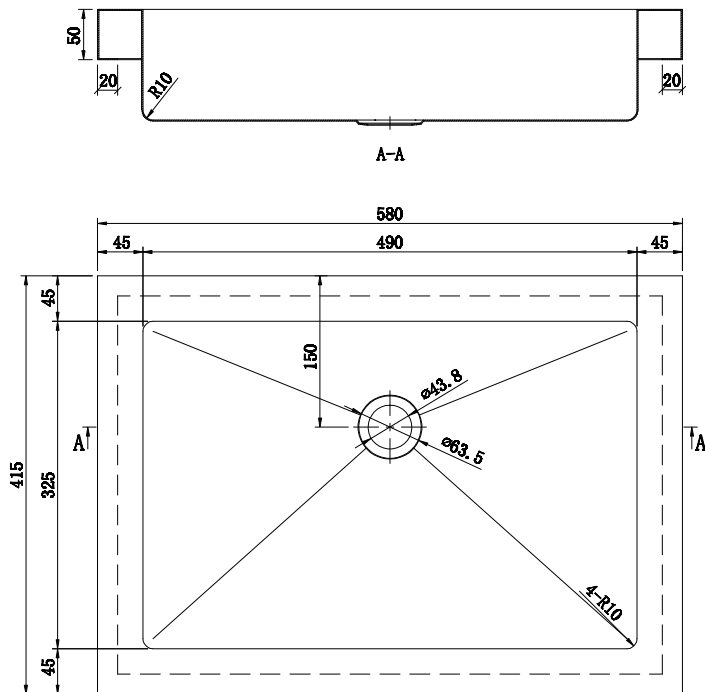

JOB INFORMATION:

Job Name _____
 Date Specified _____
 Contractor _____

Specifications and drawings provided on this sheet are for illustration only. Cantrio Concepts will not be held responsible for cutouts made without the actual product or product template.

Dimensions may vary within industry standard tolerances. Cantrio Concepts reserves the right to make changes without notice.