

MS-018

FEATURES:

- * Sink Size: 25" x 22" x 11-7/8"
- * Material: 304 Stainless Steel, 18 Gauge
- * Chrome Nickel Content 18 / 10
- * Single Basin Topmount 10mm Radius Sink
- * With Undercoating and Padding
- * Handmade Construction
- * Recommended Drain DS-005 Provided
- * Warranty: Limited Lifetime Warranty

CODES / STANDARDS APPLICABLE

- * CSA B45
- * ASME A112.19.2

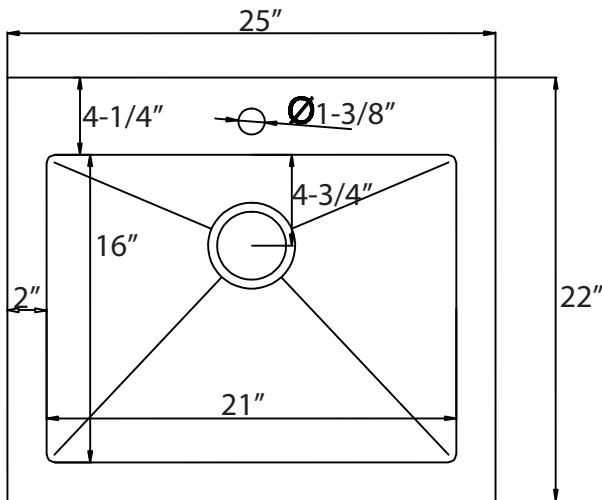

TOP VIEW

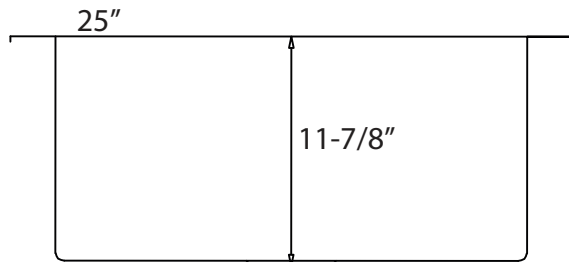

FRONT VIEW

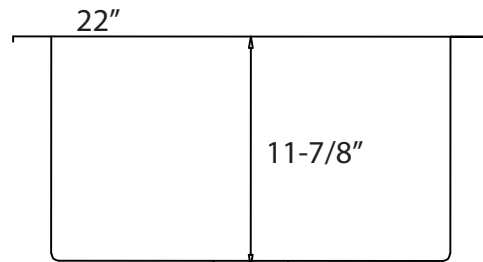

SIDE VIEW

JOB INFORMATION:

Job Name _____

Date Specified _____

Contractor _____

Specifications and drawings provided on this sheet are for illustration only. Cantrio Concepts will not be held responsible for cutouts made without the actual product or product template.

Dimensions may vary within industry standard tolerances. Cantrio Concepts reserves the right to make changes without notice.