

KSS-522

FEATURES:

- * Sink Size: 31 1/4" x 20 1/2" x 7-1/2"
- * Material: 304 Stainless Steel, 19 Gauge
- * Double Basin Topmount Sink
- * Strainer Drain Provided
- * Warranty: Limited Lifetime Warranty

CODES / STANDARDS APPLICABLE

- * CSA B45
- * ASME A112.19.2

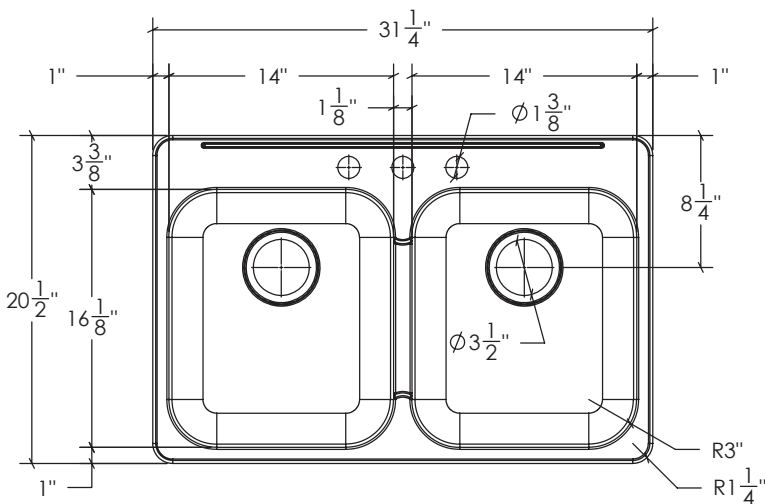

TOP VIEW

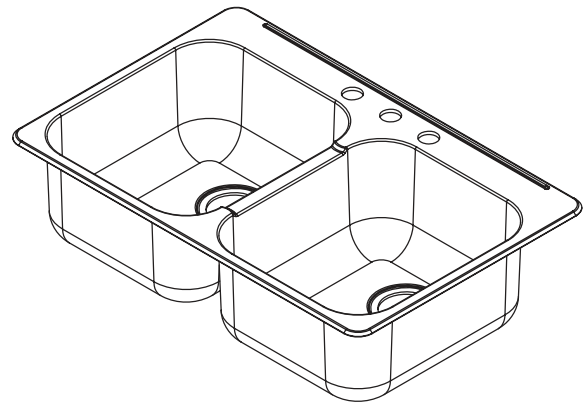

3D VIEW

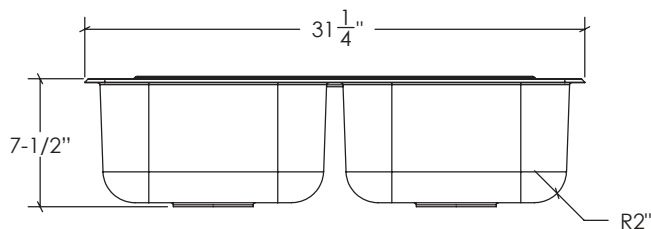

FRONT VIEW

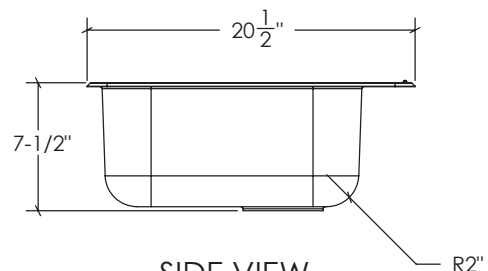

SIDE VIEW

JOB INFORMATION:

Job Name _____
 Date Specified _____
 Contractor _____

* Specifications and drawings provided on this sheet are for illustration only. Cantrio Concepts will not be held responsible for cutouts made without the actual product or product template.