

KSS-508

FEATURES:

- * Sink Size: 31 1/4" x 17 3/4" x 9 1/4"
- * Material: 304 Stainless Steel, 18 Gauge
- * 18/10 Chrome-Nickel content
- * Double Basin Undermount Sink
- * High Luster finish
- * Strainer Drain Provided
- * Warranty: Limited Lifetime Warranty

CODES / STANDARDS APPLICABLE

- * CSA B45
- * ASME A112.19.2

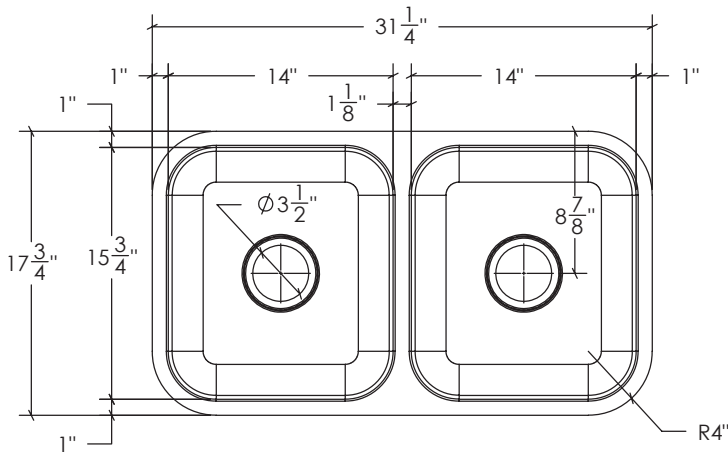

TOP VIEW

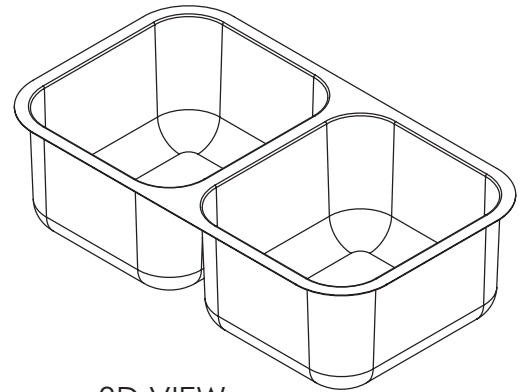

3D VIEW

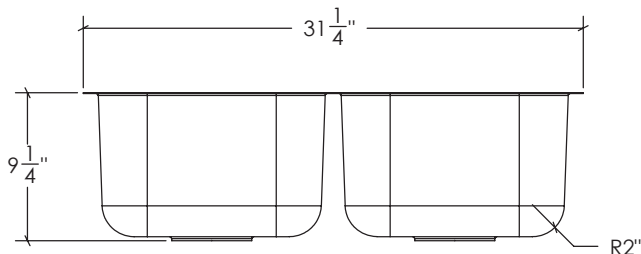

FRONT VIEW

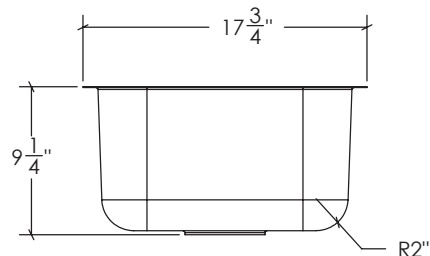

SIDE VIEW

JOB INFORMATION:

Job Name _____
 Date Specified _____
 Contractor _____

* Specifications and drawings provided on this sheet are for illustration only. Cantrio Concepts will not be held responsible for cutouts made without the actual product or product template.