



KSS-2018

FEATURES:

- * Sink Size: 20" x 18" x 8"
- * Material: 304 Stainless Steel
- * 18 Gauge
- * Nickel Content 18/10
- * For Undermount or Self Rimming Use
- * With Undercoating & Padding
- * Recommended Drain: DS-003
- * Drain Opening 3-1/2"
- * Strainer Drains Included
- * Warranty: One Year Limited Warranty

CODES / STANDARDS APPLICABLE:

- * CSA B45
- * ASME A112.19.2

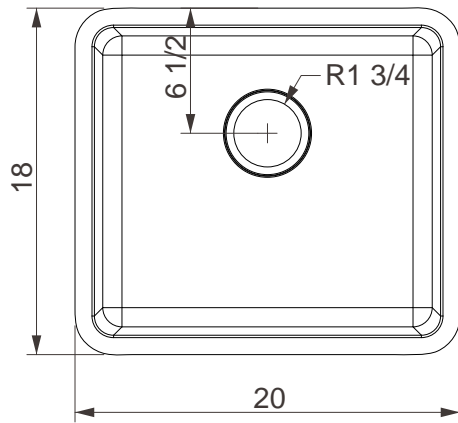

TOP VIEW

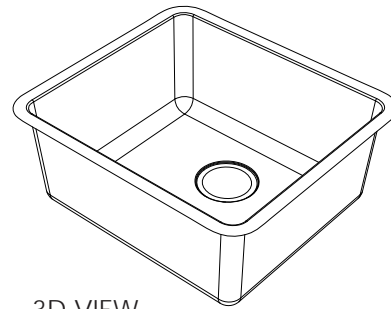

3D VIEW

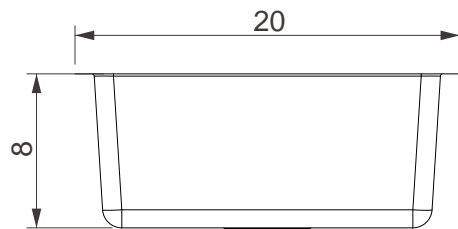

FRONT VIEW

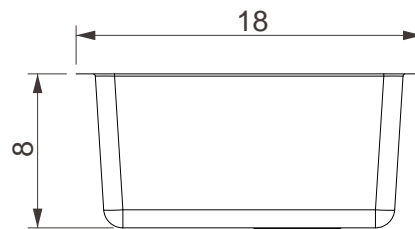

SIDE VIEW

JOB INFORMATION:

Job Name _____
 Date Specified _____
 Contractor _____

* Specifications and drawings provided on this sheet are for illustration only. Cantrio Concepts will not be held responsible for cutouts made without the actual product or product template.