



KS-002

FEATURES:

- * Sink Size: 29" x 18" x 9 1/4"
- * Material: 304 Stainless Steel, 18 Gauge
- * Chrome Nickel content 18 / 10
- * Double Basin Undermount 0 Radius Sink
- * Strainer Drain Provided
- * Warranty: Limited Lifetime Warranty

CODES / STANDARDS APPLICABLE

- * CSA B45
- * ASME A112.19.2

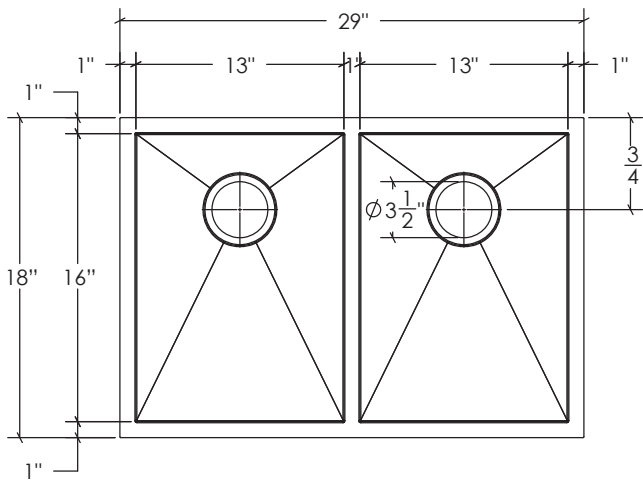

TOP VIEW

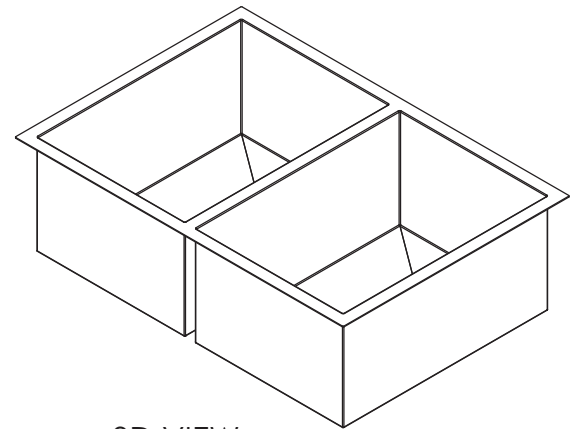

3D VIEW

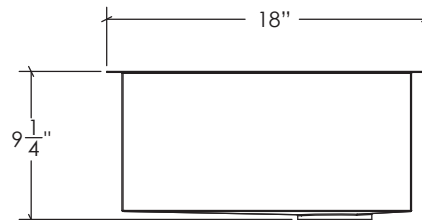
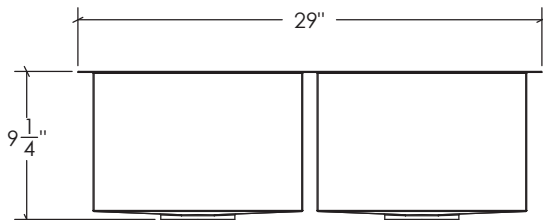

JOB INFORMATION:

Job Name _____
 Date Specified _____
 Contractor _____

* Specifications and drawings provided on this sheet are for illustration only. Cantrio Koncepts will not be held responsible for cutouts made without the actual product or product template.