

# Kräus®

INSTALLATION MANUAL

## **Britt™ Sensor Commercial Pull Down Kitchen Faucet**

**KSF-1691**

## **Congratulations on the purchase of your new Kraus® plumbing fixture!**

Please keep the box and packaging materials until your product is completely installed. If you have any questions, require technical assistance or have any problems with your product:



**DO NOT RETURN TO STORE**

**Please contact our Customer Service Team  
1-800-775-0703 / [customerservice@kraususa.com](mailto:customerservice@kraususa.com)**

Have the model number available and retain a copy of your receipt with purchase date for reference.

If for any reason this product does not meet your expectations, please be sure to repack this product in the original box and packaging material to avoid damage during transit.

**STOP**

### Prior to Installation:

- Make sure you have all necessary parts by checking the diagram and parts list. If any part is missing or damaged, please contact Kraus<sup>®</sup> Customer Service at 800-775-0703 for a replacement.
- Read all instructions and safety warnings and ensure you have all tools, parts, and equipment necessary for a safe installation.
- Turn off the hot and cold water supply at the angle stops and turn on the old faucet to release any built up pressure. Remove existing faucet.
- Pre-drilled hole size requirement: 1 3/8" (min)
- Max countertop thickness: 3 1/8"

For technical assistance or replacement parts, please contact Kraus Customer Service and one of our representatives will be happy to help:  
Toll-Free: 800-775-0703 or [Customerservice@kraususa.com](mailto:Customerservice@kraususa.com)

### Tools Required



### Care & Maintenance

- \* To keep the product clean & shining, follow the steps below:
  1. Rinse with clean water & dry with a soft cloth
  2. Do not clean with soaps, acid, polish, abrasives or harsh cleaners
  3. Do not use cloth with a coarse surface
  4. Unscrew the aerator and clean when necessary
- \* This installation manual is subject to change without further notice.



## Diagram and Parts List

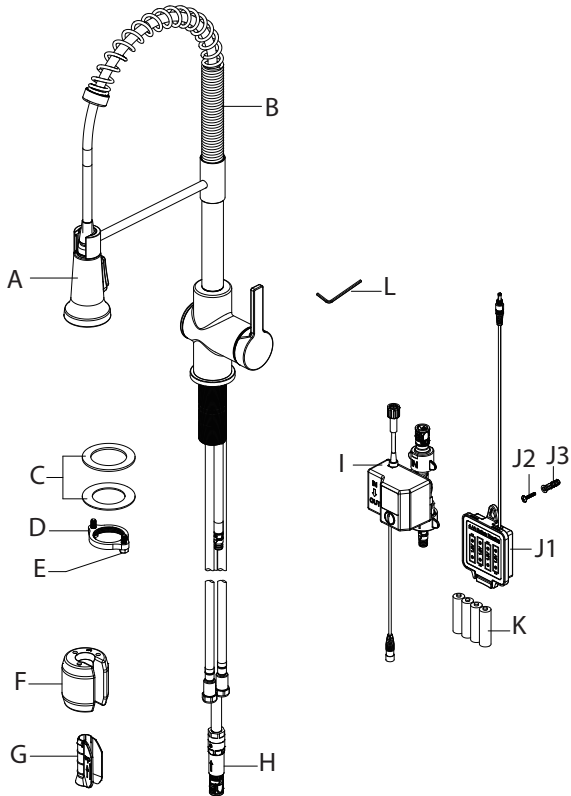

A. Spray Head  
 B. Faucet Body  
 C. Washers  
 D. Mounting Nut  
 E. Screws  
 F. Weight  
 G. Weight Clip  
 H. Quick Connector Assembly

I. Sensor Control Box  
 J. Battery Pack  
   J1. Battery Pack  
   J2. Screw  
   J3. Anchor  
 K. Battery  
 L. 2.5mm Hex Wrench

# Faucet Dimensions

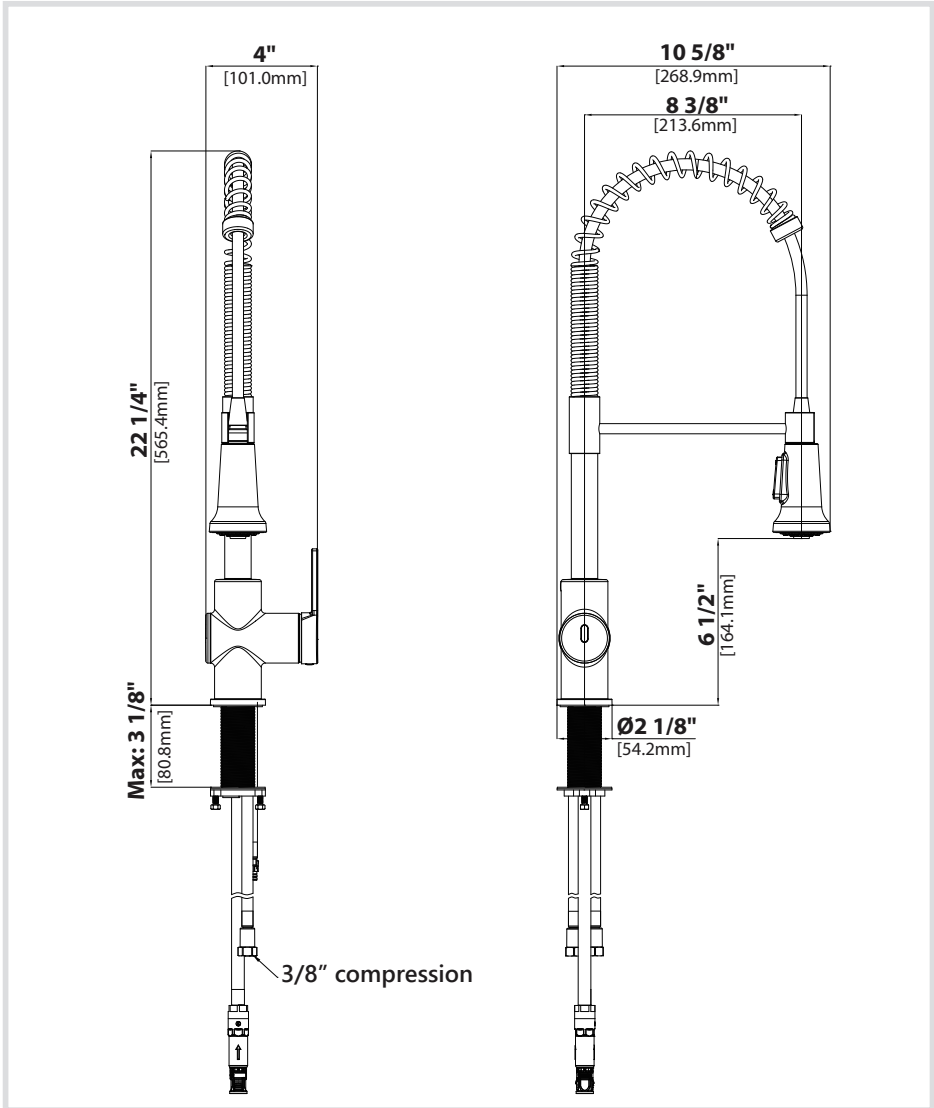

## Installer Tip:

Shut off main water supply before installing new faucet.

## Step 1: Installing the faucet

---

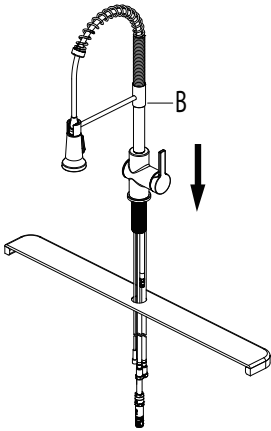

Shut off the water supply. Insert faucet body (B) through the hole in the sink.

## Step 2: Securing the faucet assembly

---

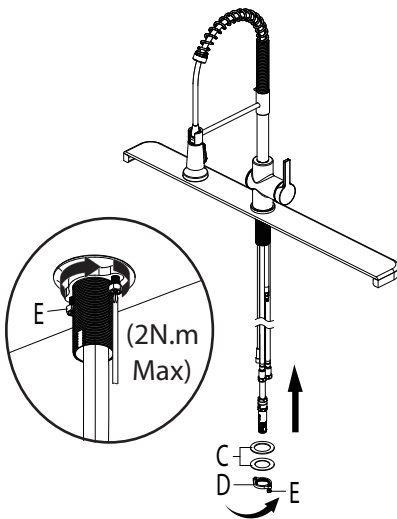

Secure the faucet (B) to the countertop using the washers (C) and mounting nut (D) provided. Hand tighten the nut (D) onto the faucet assembly. Lock the nut (D) into position by tightening the screws (E) with a phillips screwdriver. Do not overtighten.

### Step 3: Installing the sensor control box

---

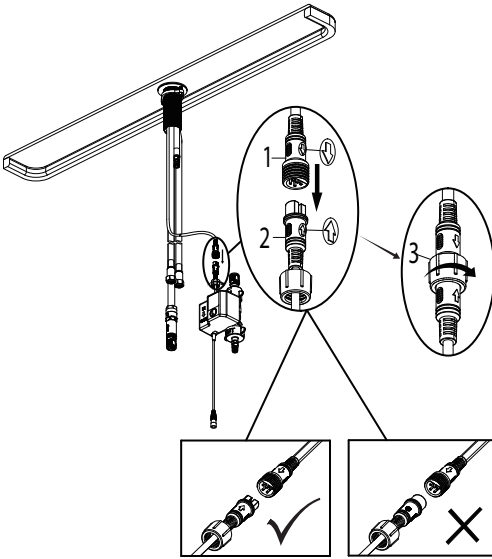

Install the data cable (1) to the control box connection (2). Ensure the arrows on the data cable and control box connection are aligned to one another to ensure proper installation. Ensure they are tightly connected by firmly pushing together. Secure the connection by hand tightening the nut (3) in a clockwise direction onto the threaded sensor cable.

**CAUTION:** If the connections are not made properly, the sensor feature will not work.

### Step 4: Installing the sensor control box

---

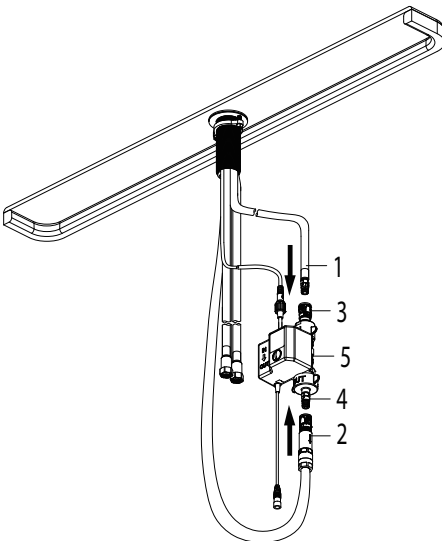

Connect the hose (1 & 2) to the connector (3 & 4) on the control box (5). Push firmly together until they snap into place.

## Step 5: Installing the counterweight

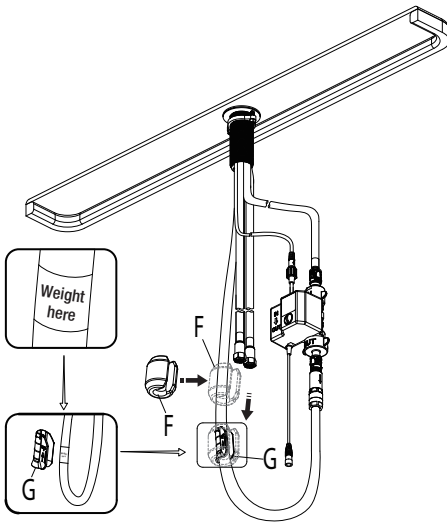

Install the weight clip (G) at the point of the hose marking "weight here". Insert the weight (F) onto the weight clip (G) by sliding it down onto the weight clip (G).

## Step 6: Installing the battery pack

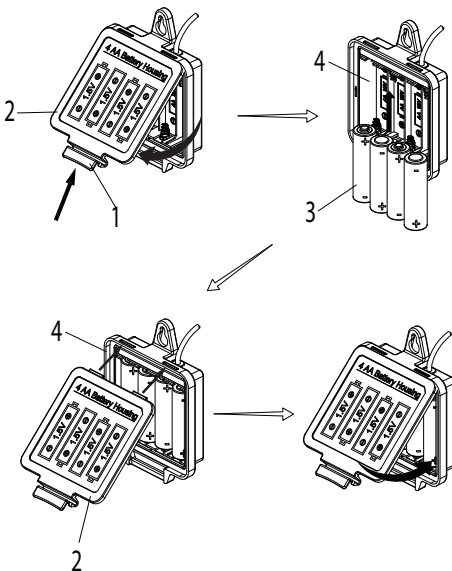

To open the battery housing, squeeze the tabs (1) on the cover (2), then remove the cover (2). Install the four AA batteries (3) included by matching the positive (+) and negative (-) ends on the battery (3) to the (+) and (-) markings in the battery pack (4). The negative ends of the battery (3) should always connect to the spring end of the battery slots in the battery pack (4). Reinstall the battery pack cover (2) by pushing up and snapping into place.

**NOTE:** When the sensor flashes 10 times continuously and slowly, the batteries have lost their charge. Replace the batteries (3).

## Step 7: Installing the battery pack

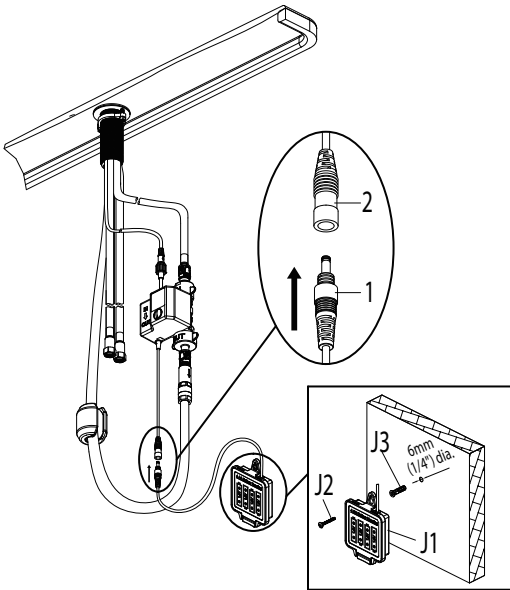

Drill a hole in the wall using a 6mm (1/4 in.) diameter drill bit. Install the battery pack (J1) using the molly anchor (J3) and screw (J2) provided. Insert the battery pack cable (1) into the control box connection (2).

**NOTE:** After installing the battery pack, the light on the sensor will flash and the faucet will sound when you move your hand in the sensor area. If not, check to ensure the batteries are installed correctly.

## Step 8: Connect waterlines to main valve

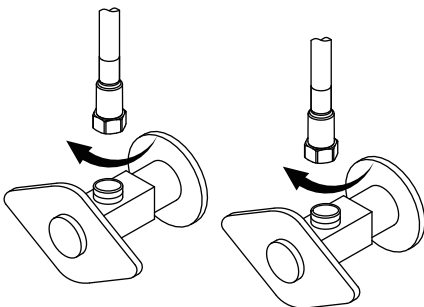

Attach waterlines to angle stops and tighten until snug. Turn on angle stops and check for leaks (**DO NOT TURN FAUCET ON**).

**NOTE:** Please make sure filter washers are installed before connecting to the main valve.

## Step 9: Flush faucet

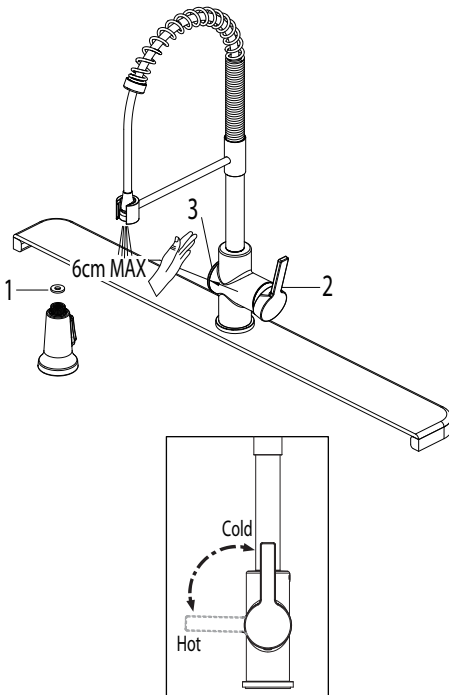

**Flushing and checking for leaks:** After the installation is complete, unscrew and remove the spray head in order to flush the line. Turn on the water supply and allow both hot and cold water to run for at least one minute each. This flushes away any debris that could cause damage to internal parts. Check for leaks. Reattach the spray head. Do not lose the gasket (1) in the hose.

**NOTE:** Please make sure washer (1) is installed attaching spray head to hose.

**Operating the sensor:** Turn the handle (2) away from the faucet to the full on position. Turn the water on by activating the sensor (3) by waving your hand within 6cm of the sensor. Move the handle towards you and away from you, the water flow pattern can be switched from hot water to cold water. If the sensor does not work, then you can refer to the troubleshooting. If you want to use the faucet without the sensor feature, then you can refer to troubleshooting 5. Then, turning on the water can be done by moving the handle away from the faucet to the full on position.

**NOTE:** The sensor is active only when the handle is in the ON position. As a water saving feature, the water will turn off automatically after 3 minutes of continuous flow.

# Replacement Parts

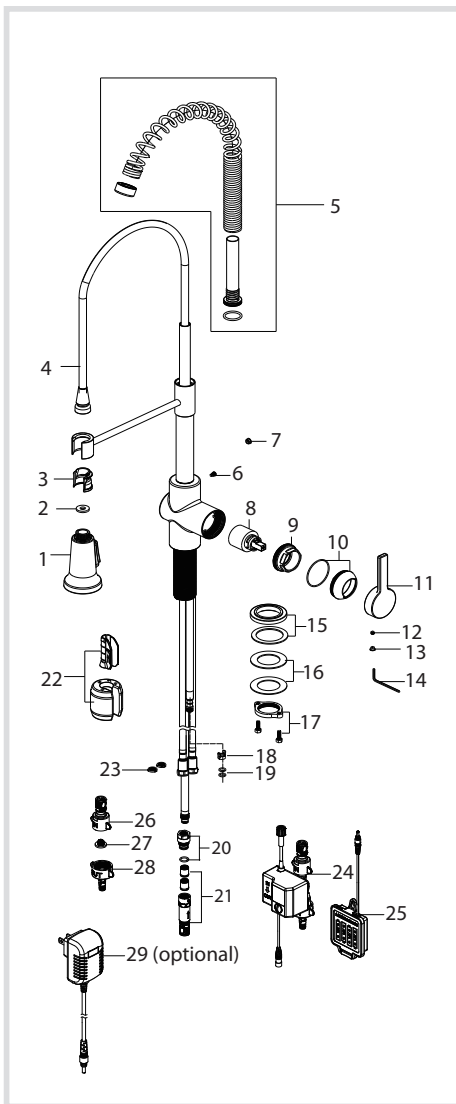

Replacement Parts List	Finish / Color	Part #
1. Spray Head	SFS, MB, SFACB**	KP27195
2. Sprayer Washer		KP27208
3. Inverter	BL, GR**	KP27242
4. Spray Hose	BLMB, GRSFS, BLSFACB*	KP27244
5. Sprayer Support Assembly	SFS, MB, SFACB**	KP27243
6. Set Screw		KP27084
7. Index	BL, GR**	KP27124
8. Cartridge		KP27083
9. Bonnet Nut		KP27238
10. Cap	SFS, MB, SFACB**	KP27239
11. Handle	SFS, MB, SFACB**	KP27240
12. Set screw		KP27001
13. Cover Button	BL, GR**	KP27002
14. Hex Wrench		KP27020
15. Flange	SFS, MB, SFACB**	KP27041
16. Rubber & metal washer		KP27028
17. Mounting nut & screws		KP27079
18. Block		KP27073
19. O-ring		KP27092
20. Connector	WHITE	KP27318-WH
21. Quick connector assembly		KP27090
22. Weight & Clip Assembly	BL**	KP27212
23. Filter Washer		KP27248
24. Control Box		KP27186
25. Battery Housing		KP27188
26. IN Connector		KP27190
27. Filter Washer		KP27189
28. OUT Connector		KP27191
29. AC Adapter		KP27187

\*Denotes spray hose assembly color options:  
 Spray hose assembly color options:  
 Black hose w/ Matte Black connector (BLMB);  
 Gray hose with Spot-Free Stainless connector (GRSFS);  
 Black hose with Spot-Free Antique Champagne Bronze (BLSFACB);

\*\*Denotes faucet component color options:  
 SFS - Spot Free Stainless Steel  
 MB - Matte Black  
 SFACB - Spot Free Antique Champagne Bronze  
 GR - Grey  
 BL - Black

# Troubleshooting

If you have followed the instructions carefully and your faucet still does not work properly, take the following corrective steps:

## Problem 1: Water will not shut off when turning the handle to the OFF position.

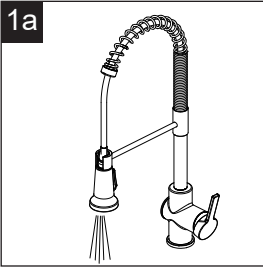

When you turn the handle to the full on position, the water will turn on.

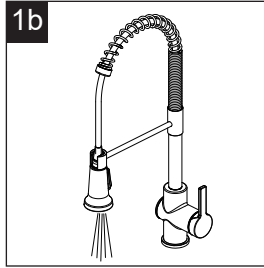

But when you turn the handle to the full off position, the water does not turn off.

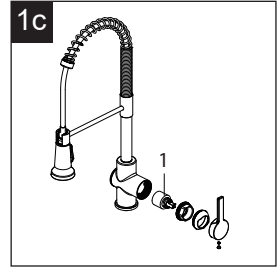

This indicates that the cartridge is damaged. Turn off the water supply, remove the handle and replace the cartridge (1).

## Problem 2: The light on the sensor is flashing continuously.

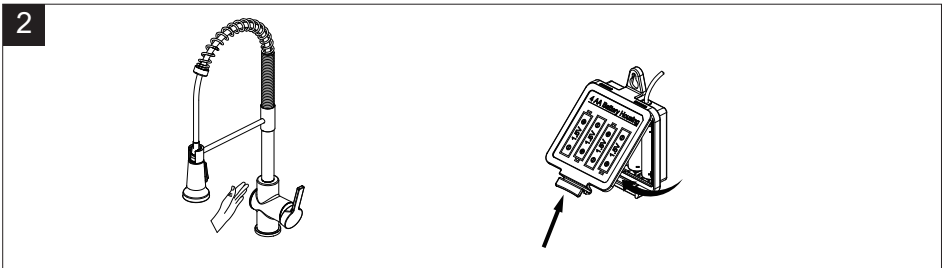

If the handle is closed, turn the handle to the on position and move your hand in the sensor area. If the sensor flashes 10 times continuously and slowly, then replace the 4 "AA" batteries.

## Problem 3: There is a low flow of water or LED indicator in the faucet body is not functioning.

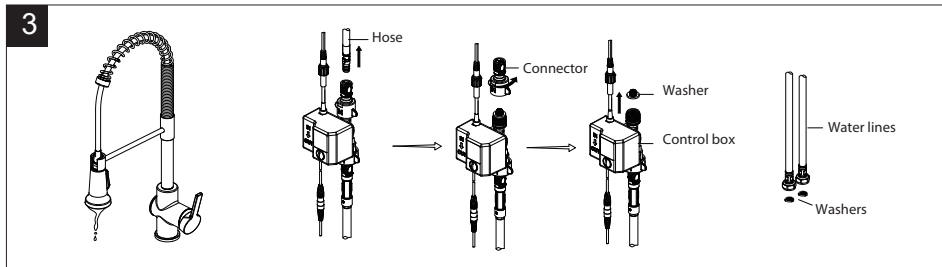

- This could indicate that the washer in the control box is dirty or damaged. Remove the hose and unscrew the connector. Take out the washer from the control box. Clean the washer or replace the washer. Reassemble the connector and hose.
- The filter washers (23 & 27) are dirty. Turn off the water supply at the water valves and unscrew the hose connectors from the water supply lines. Clean the filter washers in the water lines with hot water, removing any debris or calcium build up.

## Problem 4: The sensor is not activating the water flow.

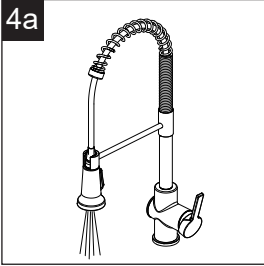

When you turn the handle to the full on position, the water will turn on.

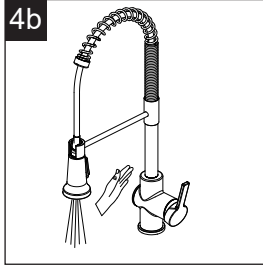

However, when you move your hand in front of the sensor, the water does not turn off as it should.

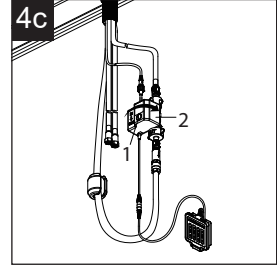

Check whether the switch button (1) is tight, if it is loose, tighten the switch button (1) completely with a coin clockwise. If the switch button (1) is tight, this indicates that the control box (2) is damaged. Call customer service to request a replacement control box. Replace the old control box with the new control box.

## Problem 5: The function of the switch button.

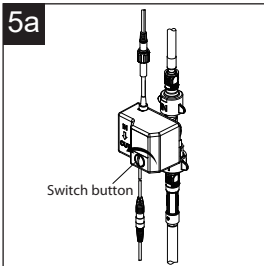

If you want to use the faucet without the sensor feature, you can loosen the switch button completely with a coin counterclockwise. At this time, you can use the sensor faucet just like a regular kitchen faucet.

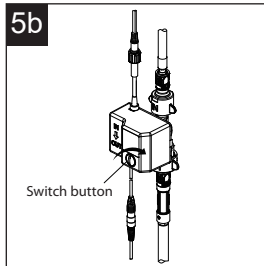

However, if you want to continue to use the faucet with the sensor feature, you need to tighten the switch button completely with a coin clockwise. At this time, you can use the faucet with the sensor feature.

## Codes/Standards Applicable:



NSF/ANSI 61



ASME A112.18.1  
1.8GPM 6.8L/min maximum

### Faucet - Lifetime Limited Warranty

Kraus USA Plumbing, LLC ("Kraus") extends this warranty to the original purchaser for personal household use of the Faucet when purchased from an authorized Kraus dealer and in the location of original installation. This warranty is non-transferable.

Kraus warrants the structure and finish of the Faucet to be free from defects in material and workmanship under normal usage for as long as the original purchaser resides in the residence in which the Faucet was first installed.

Kraus warrants the Faucet's sprayhead assembly (including the engine, aerators, structure, restrictors, back flow preventers, sprayer hoses, braided supply line hoses which encompasses nylon, silicon and stainless steel) of the product to be free from defects in material and workmanship under normal usage for a period of one (1) year from the date of purchase.

Kraus warrants the Faucet's cartridge to be free from defects in material and workmanship under normal usage for a period of five (5) years from the date of purchase.

Any product reported to the authorized dealer or to Kraus as being defective within the warranty period will be repaired or replaced with a product of equal value at the option of Kraus.

### Commercial Warranty

Kraus USA Plumbing, LLC ("Kraus") warrants its Products for a period of one (1) year to commercial purchasers of Products used in industrial, commercial and business applications.

### Care and Cleaning Instructions

Certain cleaning products may cause damage to a Product's finish and use of the following on the Product will void this warranty:

- Abrasive cleaners such as powders, bleach, ammonia, alcohol or chlorine
- Abrasive pads, steel wool or wire brushes

### What is Not Covered

This warranty does not cover Products that were discontinued when purchased or display Products, whether such Products were purchased at discount outlets, unauthorized dealers, and/or sold on clearance. This warranty does not cover any free gifts included with purchase.

This warranty does not cover damage resulting from neglect, misuse (including use for an unintended application), abuse, carelessness, accident, hard water or mineral deposits, exposure to corrosive materials, improper maintenance, alteration of the Product, or failure to follow care, cleaning or installation instructions enclosed with your Product. Kraus recommends that all Kraus Products be installed by a fully licensed and insured trade professional with experience in the installation of bathroom and/or kitchen manufactured goods.

### How to Make a Warranty Claim

If you are a **consumer purchaser**, please contact a Kraus Customer Service Representative at:  
Kraus USA Plumbing, LLC  
12 Harbor Park Drive  
Port Washington, NY 11050  
Toll-free 800-775-0703  
Customerservice@kraususa.com

If you are a **plumbing contractor or trade professional**, please contact a Kraus Pro Representative at:  
Kraus USA Plumbing, LLC  
12 Harbor Park Drive  
Port Washington, NY 11050  
516-801-8955  
Proservice@kraususa.com

If you are an **authorized partner**, please contact a Partner Support Representative at:  
Kraus USA Plumbing, LLC  
12 Harbor Park Drive  
Port Washington, NY 11050  
516-801-8954  
Partnersupport@kraususa.com

In requesting warranty service, please be ready to provide your proof of purchase and a description of the problem. Shipping charges will be covered for the first (1) year of the warranted replacement part or product (HI, AK, and Puerto Rico shipping charges may apply). International shipping fees are not included.

### Limitation on Duration of Implied Warranties

Please note that some states/provinces (including Quebec) do not allow limitations on how long an implied warranty lasts, so the below limitations may not apply to you. TO THE MAXIMUM EXTENT PERMITTED BY APPLICABLE LAW, ANY IMPLIED WARRANTY, INCLUDING THE IMPLIED WARRANTIES OF MERCHANTABILITY AND OF FITNESS FOR A PARTICULAR PURPOSE, IS LIMITED TO THE STATUTORY PERIOD OR THE DURATION OF THIS WARRANTY, WHICHEVER IS SHORTER.

### Limitation of Special, Incidental or Consequential Damages

Please note that some states/provinces (including Quebec) do not allow the exclusion or limitation of special, incidental or consequential damages, so the below limitations and exclusions may not apply to you. TO THE MAXIMUM EXTENT PERMITTED BY APPLICABLE LAW, THIS WARRANTY DOES NOT COVER, AND KRAUS USA PLUMBING, LLC SHALL NOT BE LIABLE FOR, ANY SPECIAL, INCIDENTAL OR CONSEQUENTIAL DAMAGES (INCLUDING LABOR CHARGES TO REPAIR, REPLACE, INSTALL OR REMOVE THIS PRODUCT), WHETHER ARISING OUT OF BREACH OF ANY EXPRESS OR IMPLIED WARRANTY, BREACH OF CONTRACT, TORT, OR OTHERWISE.

This warranty gives you specific legal rights, and you may also have other rights which vary from state/province to state/province.

**Download the Kraus Care & Maintenance Guide at:**  
<http://www.kraususa.com/maintenance>

# IMPORTANT

## Register Your Kraus Product

**Activate** Your Warranty

**Access** Premium Customer Support

**Get** Product Information

**REGISTER TODAY**

<http://www.kraususa.com/registration>



**Kräus**<sup>®</sup>  
www.kraususa.com