



Britt™ Single Handle Commercial Kitchen Faucet

KPF-1690

Congratulations on the purchase of your new Kraus plumbing fixture!

Please keep the box and packaging materials until your product is completely installed. If you have any questions, require technical assistance or have any problems with your product:



DO NOT RETURN TO STORE

**Please contact our Customer Service Team
1-800-775-0703 / customerservice@kraususa.com**

Have the model number available and retain a copy of your receipt with purchase date for reference.

If for any reason this product does not meet your expectations, please be sure to repack this product in the original box and packaging material to avoid damage during transit.

Prior to Installation:

- Make sure you have all necessary parts by checking the diagram and parts list. If any part is missing or damaged, please contact Kraus Customer Service at 800-775-0703 for a replacement.
- Turn off the hot and cold water supply at the angle stops and turn on the old faucet to release any built up pressure. Remove existing faucet. Clean sink or countertop to remove any debris, plumber's putty, or silicone.
- Place bucket under angle stops. Turn on angle stops to flush any debris prior to installing new plumbing. Shut off angle stops.
- Max countertop thickness: 3"
- Pre-drilled hole size requirement: 1 3/8"
- 1 or 3 hole installation

For technical assistance or replacement parts, please contact Kraus Customer Service and one of our representatives will be happy to help:

Toll-Free: 800-775-0703 or customerservice@kraususa.com

Tools you will need:



Adjustable Wrench



Bucket

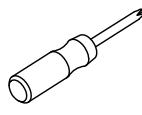

Phillips Screwdriver



Safety Goggles

Diagram and Parts List

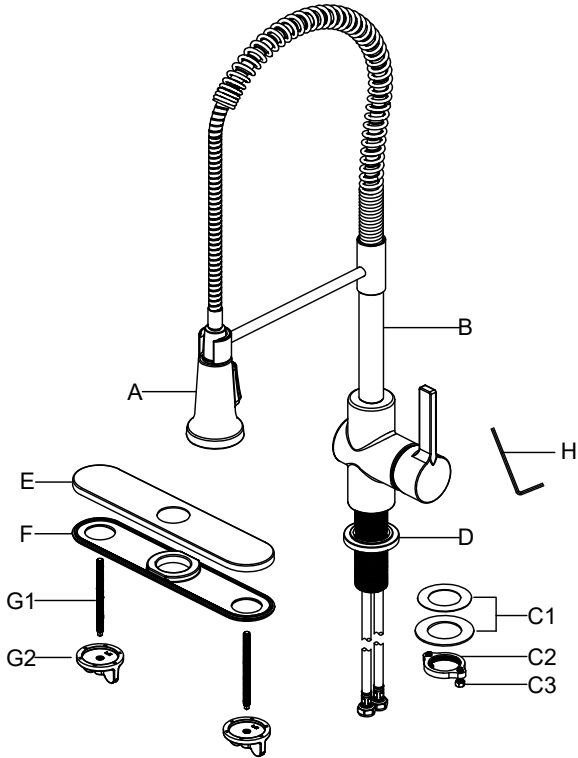

A. Spray Head

B. Faucet Body

C. Mounting Hardware

C1. Rubber & Metal Washer

C2. Mounting Nut

C3. Mounting Screw

D. Flange & Washer

E. Escutcheon

F. Base Plate

G. Escutcheon Mounting Hardware

G1. Bolt

G2. Plastic Nut

H. 2.5 mm Hex Wrench

Faucet Dimensions

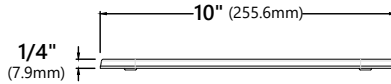
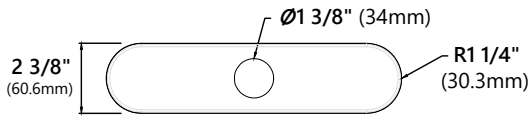
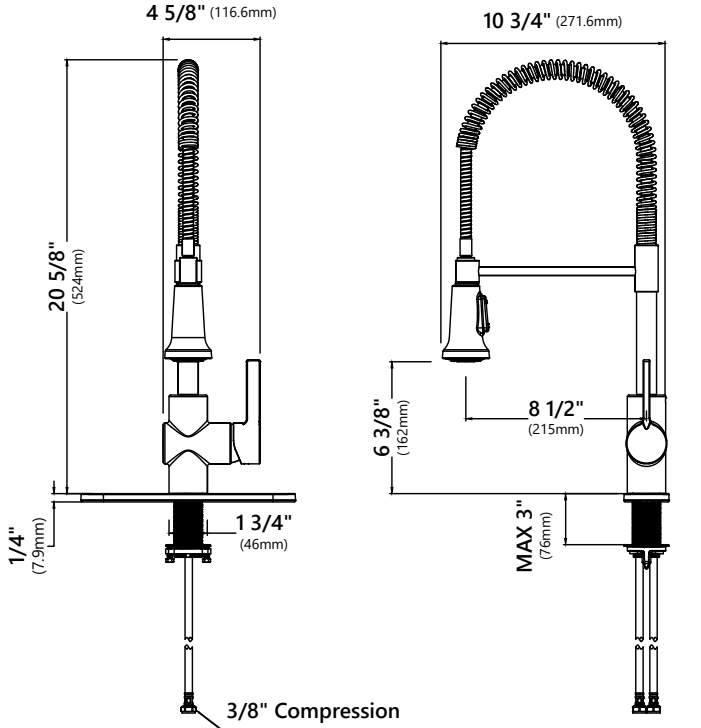

* Optional Deck Plate

Step 1. Remove mounting hardware

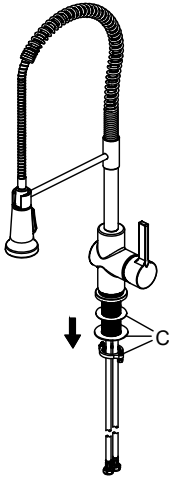

Shut off the water supply. Remove the old faucet. Clean the mounting surface. Remove mounting hardware (C) from faucet body (B).

Step 2. Install the faucet assembly (without deckplate)

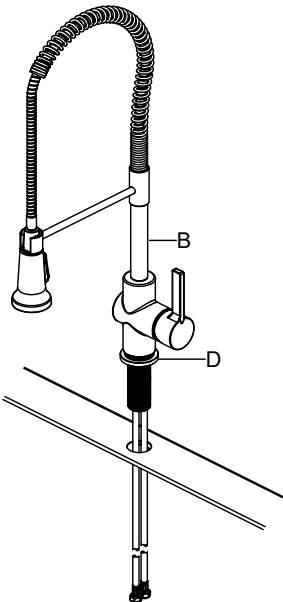

Before installation, ensure that the flange (D) is placed on the bottom of the new faucet assembly (B). Insert the faucet body through the hole in the sink.

NOTE: Skip this step and move on to Step 3 if installing with deckplate.

Step 3. Install the escutcheon

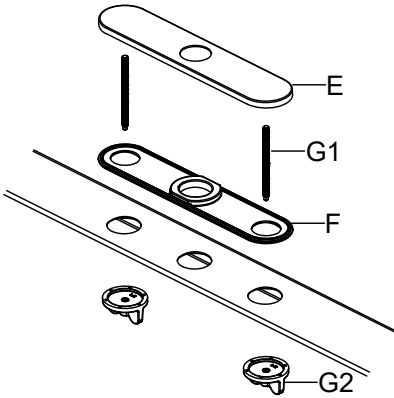

Before installation, remove the flange (D). Screw the bolts (G1) into the escutcheon (E) and ensure that the base plate (F) is pressed onto the escutcheon (E) before the escutcheon (E) is installed over the three holes on the sink. From underneath the sink, hand tighten the mounting nuts (G2). Do not overtighten.

NOTE: Skip this step if installing without deckplate.

Step 4. Install the faucet assembly (with deckplate)

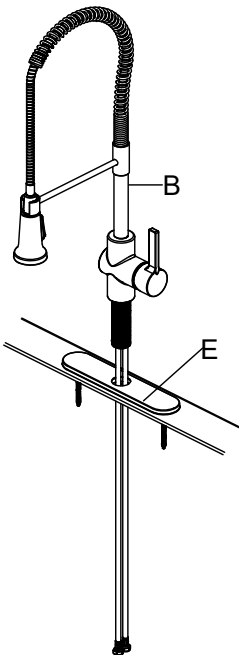

Insert the faucet assembly (B) through the hole in the escutcheon (E).

NOTE: Skip this step if installing without deckplate.

Step 5. Secure the faucet assembly

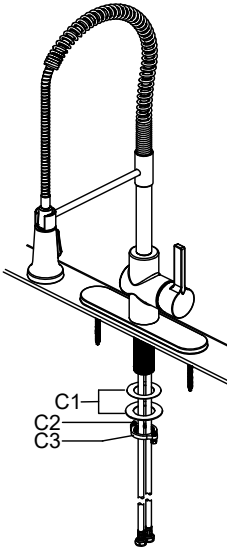

Install the plastic washer and metal washer (C1) onto the threaded mounting shank. Thread the nut (C2) onto the mounting shank. Lock the nut (C2) into position by tightening the screws (C3). Do not overtighten.

Step 6. Connect the waterlines

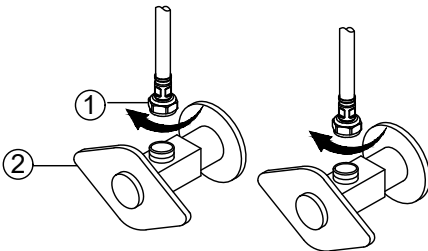

Thread the nut (1) on the supply line onto the outlet of the water supply valve (2) and tighten with wrench. Do not overtighten.

NOTE: Please make sure filter washers are installed before connecting to the main valve.

Step 7. Flush and check for leaks

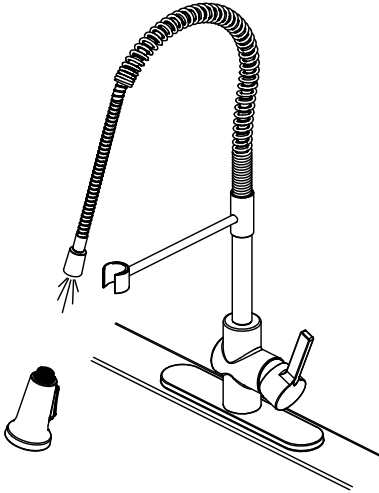

Pull hose assembly out of spout and remove spray head by unscrewing from hose in a counterclockwise direction. Hold the end of the hose down into the sink and turn the faucet on to the warm position. Flush water lines for one minute to flush away any debris. Check for leaks.

Re-tighten any connections if needed. Do not overtighten. Reinstall spray head by hand tightening it back onto the spray hose. After installation is completed, turn on the hot and cold water supplies to check for leaks.

Replacement Parts

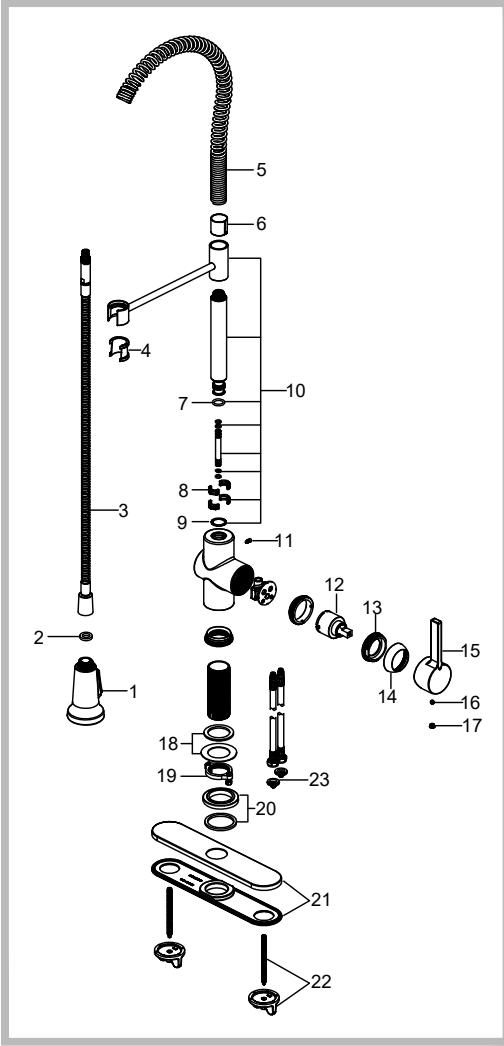

Replacement Parts List	Finish/Color	Part #
1. Spray Head	SFS,BG,SFACB,SFSB,MB,AB*	KP27195
2. 1.8 GPM Washer		KP27196
3. Sprayer Hose	BLAB,BLBG,BLSFSB BLMB,BLSFACB,SFS*	KP27025
4. Inverter	GR,BL*	KP27026
5. Spring	SFS,BG,SFACB,SFSB,AB*	KP27027
6. Inverter	GR,BL*	KP27080
7. O-ring		KP27029
8. Block		KP27030
9. Washer	GR,BL*	KP27031
10. Spray Support Assembly	SFS,AB,BG,SFSBMB SFACBMB,BGMB*	KP27032
11. Set Screw		KP27033
12. Cartridge		KP27035
13. Bonnet Nut		KP27036
14. Cap	SFS,BG,SFACB,SFSB,AB*	KP27037
15. Handle	SFS,BG,SFACB,SFSB,AB*	KP27038
16. Set Screw		KP27001
17. Cover Button	GR,BL*	KP27002
18. Rubber & Metal Washer		KP27028
19. Nut & Screw		KP27079
20. Flange	SFS,BG,SFACB,SFSB,AB*	KP27041
21. Escutcheon	SFS,BG,SFACB,SFSB,AB*	KP27184
22. Escutcheon Mounting Hardware		KP27185
23. Filter Washer		KP27167

*Denotes faucet component color options:
 SFS - Spot Free Stainless Steel
 MB - Matte Black
 BG - Brushed Gold
 SFACB - Spot Free Antique Champagne Bronze
 SFSB - Spot Free Black Stainless
 AB - Antique Brass
 BL - Black
 GR - Gray

Troubleshooting

If you have followed the instructions carefully and your faucet still does not work properly, take the following corrective steps:

PROBLEM	CAUSE	ACTION
Leakage under faucet handle	The bonnet nut (14) has come loose and the ring on the cartridge is dirty or damaged	Tighten the bonnet nut. Clean or replace the cartridge
Leaking between spray head and the hose	Spray head (1) may be loose or washer (3) is not seated correctly in the hose connection.	Tighten spray head (1) by hand until snug. Make sure washer (3) is seated correctly
The water pressure is low	Waterlines may be clogged	Turn off the water supply at water valve and unscrew the hose connectors from water supply lines. Clean the screen in the water lines with hot water, removing any debris or calcium build up.

Care & Maintenance

To keep the product clean & shining, follow the steps below:

1. Rinse with clean water & dry with a soft cloth
2. Do not clean with soaps, acid, polish, abrasives or harsh cleaners
3. Do not use cloth with a coarse surface
4. Unscrew the aerator and clean when necessary



Download the Kraus Care & Maintenance Guide at:

<http://www.kraususa.com/maintenance>

This installation manual is subject to change without further notice.

Codes/Standards Applicable:



ASME A112.18.1
1.8GPM 6.8L/min maximum

FAUCET WARRANTY

Kraus products are manufactured and tested to the highest quality standards by Kraus USA Inc. ("Kraus").

Kraus extends this warranty to the original purchaser for personal household use of the "Faucet" in its original location. The warranty is non-transferable.

Kraus warrants the structure and finish of the product to be free from defects in material and workmanship under normal usage for the lifetime of the product. The warranty commences from the initial date of purchase by the owner or trade professional, from an authorized Kraus dealer, through the lifetime of the original owner or end-user.

Kraus warrants the mechanical components such as but not limited to sprayhead assembly (includes engine, aerators, structure, restrictors, back flow preventers, sprayer hoses, braided supply line hoses which encompasses nylon, silicon and stainless steel, etc) of the product to be free from defects in material and workmanship under normal usage for a period of one (1) year. The warranty commences from the initial date of purchase by the owner or trade professional, from an authorized Kraus dealer, through the one (1) year term of the original owner or end-user.

Kraus warrants the mechanical component (cartridge) of the product to be free from defects in material and workmanship under normal usage for a period of five (5) years. The warranty commences from the initial date of purchase by the owner or trade professional, from an authorized Kraus dealer, through the five (5) year term of the original owner or end-user.

Any product reported to the authorized dealer or to Kraus as being defective within the warranty period will be repaired or replaced with a product of equal value at the option of Kraus. This warranty extends to the original owner or end-user, and is not transferable to a subsequent owner.

RESTRICTIONS

This warranty does not cover antediluvian, discontinued, or display products, whether such items are purchased at discount outlets, unauthorized dealers, and/or sold on clearance.

This warranty does not cover instances of negligence, misuse, abuse, improper installation, carelessness, accident, hard water or mineral deposits, exposure to corrosive materials, misapplication, damages caused by improper maintenance, alteration of the product, or failure to follow care or installation instructions enclosed with your product. Avoid using abrasive cleaners such as powders, bleach, ammonia, alcohol, or chlorine. Avoid using abrasive pads, steel wool, or wire brushes, as these will damage and wear down the finish.

This warranty does not apply to Products that have not been installed or operated in accordance with instructions supplied by Kraus and all applicable rules, regulations, and legislation pertaining to such installations.

This warranty does not apply unless the Kraus product is installed by a fully insured and licensed trade professional. Kraus insists that such professionals have experience in the installation of bathroom and kitchen manufactured goods.

This warranty does not cover labor charges or costs of removal and reinstallation of said product. This warranty does not allow recovery of incidental or consequential damages, such as loss of use, delay, property damage, or other consequential damages, and Kraus accepts no liability for such damages.

This warranty does not cover Marine or Outdoor Installation.

Except as otherwise provided above, Kraus makes no warranties, expressed or implied, including warranties of merchantability and fitness for a particular purpose, or compliance with any code.

Shipping charges will be covered for the first (1) year of the warranted replacement part or product (HI, AK, and Puerto Rico shipping charges may apply). International shipping fees are not included.

COMMERCIAL WARRANTY

Kraus extends the above warranty for a period of one (1) year to purchasers of products for industrial, commercial, and business use.

All incidental or consequential damages are specifically excluded. No additional warranties, express or implied, are given, including but not limited to any implied warranty of merchantability or fitness for a particular purpose.

Some states do not allow the exclusion or limitation of incidental or consequential damages or limitations on how long an implied warranty lasts, so the above limitations or exclusions may not apply to you.

This warranty gives you specific legal rights, and you may also have other rights which vary from state to state.

KRAUS USA has the right to change, modify, and/or update the warranty policy at any time. For the latest, most up to date comprehensive warranty, go to www.kraususa.com/warranty

If you are a homeowner please contact a Kraus Customer Service Representative at:

Kraus USA, Inc.
12 Harbor Park Drive
Port Washington, NY 11050
Toll-free 800-775-0703
Customerservice@kraususa.com

If you are a plumbing contractor or trade professional please contact a Kraus Pro Representative at:

Kraus USA, Inc.
12 Harbor Park Drive
Port Washington, NY 11050
516-801-8955
Proservice@kraususa.com

If you are an Authorized Partner please contact a Partner Support Representative at:

Kraus USA, Inc.
12 Harbor Park Drive
Port Washington, NY 11050
516-801-8954
Partnersupport@kraususa.com

In requesting warranty service, please be ready to provide:

1. Proof of purchase.
2. A description of the problem.

IMPORTANT

Register Your Kraus Product

Activate Your Warranty

Access Premium Customer Support

Get Product Information

REGISTER TODAY

<http://www.kraususa.com/registration>



Kräus[®]
www.kraususa.com