

Kräus[®]

INSTALLATION MANUAL

Purita™ Single Handle Water Filtration Faucet

FF-100

Congratulations on the purchase of your new Kraus® plumbing fixture!

Please keep the box and packaging materials until your product is completely installed. If you have any questions, require technical assistance or have any problems with your product:



DO NOT RETURN TO STORE

**Please contact our Customer Service Team
1-800-775-0703 / customerservice@kraususa.com**

Have the model number available and retain a copy of your receipt with purchase date for reference.

If for any reason this product does not meet your expectations, please be sure to repack this product in the original box and packaging material to avoid damage during transit.



Prior to Installation:

- Make sure you have all necessary parts by checking the diagram and parts list. If any part is missing or damaged, please contact Kraus[®] Customer Service at 800-775-0703 for a replacement.
- Read all instructions and safety warnings and ensure you have all tools, parts, and equipment necessary for a safe installation.
- Turn off the hot and cold water supply at the angle stops and turn on the old faucet to release any built up pressure. Remove existing faucet.
- Pre-drilled hole size requirement: 1 1/4" (min)
- Max countertop thickness: 3 1/16"

For technical assistance or replacement parts, please contact Kraus Customer Service and one of our representatives will be happy to help:
Toll-Free: 800-775-0703 or Customerservice@kraususa.com

Tools Required



Care & Maintenance

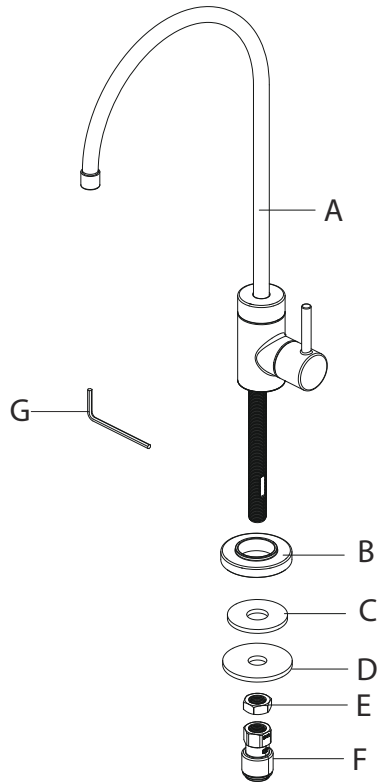
* To keep the product clean & shining, follow the steps below:

1. Rinse with clean water & dry with a soft cloth
2. Do not clean with soaps, acid, polish, abrasives or harsh cleaners
3. Do not use cloth with a coarse surface
4. Unscrew the aerator and clean when necessary

* This installation manual is subject to change without further notice.

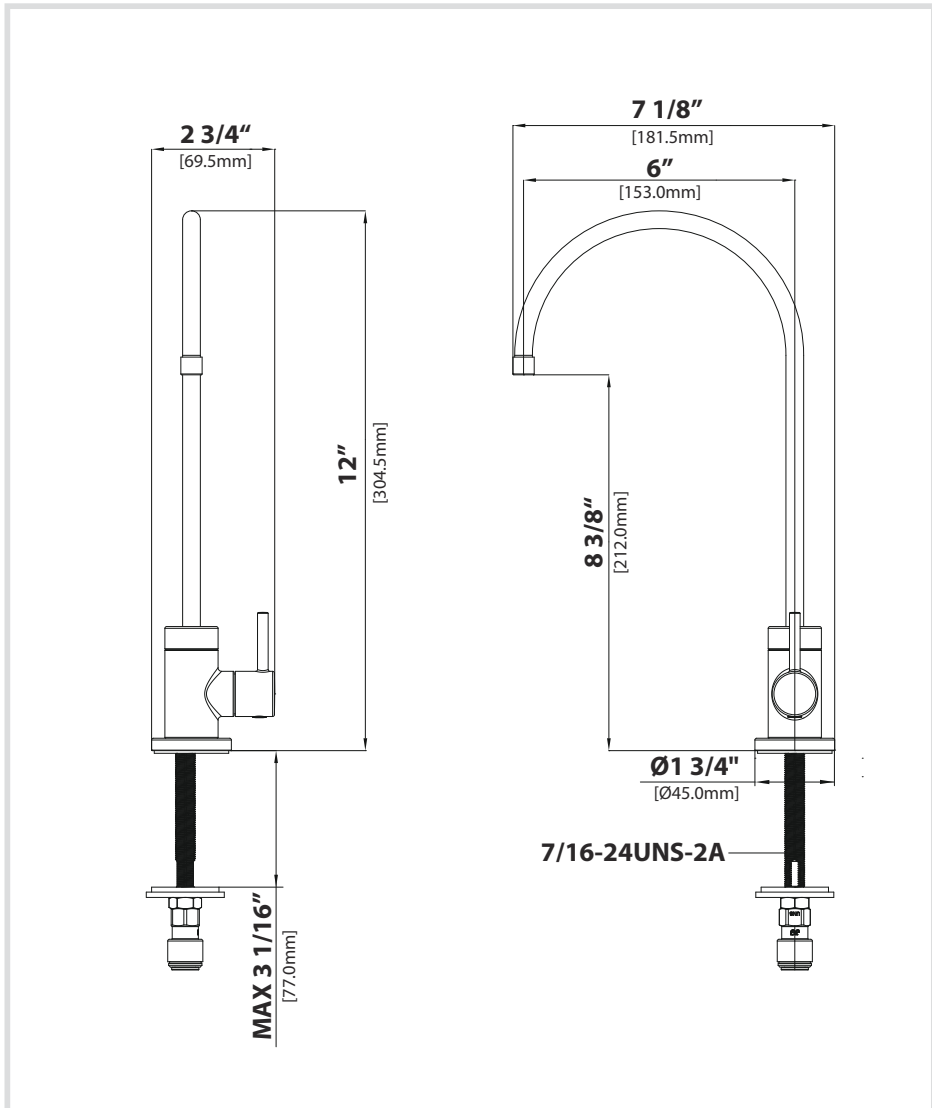


Diagram and Parts List



- A. Faucet Assembly
- B. Flange
- C. Rubber Washer
- D. Metal Washer
- E. Mounting Nut
- F. Connector
- G. Hex Wrench

Faucet Dimensions

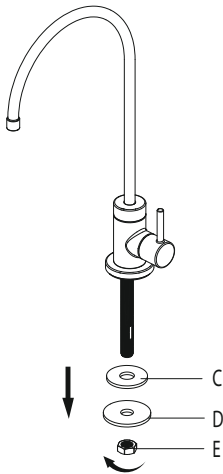


Installer Tip:

Shut off main water supply before installing new faucet.

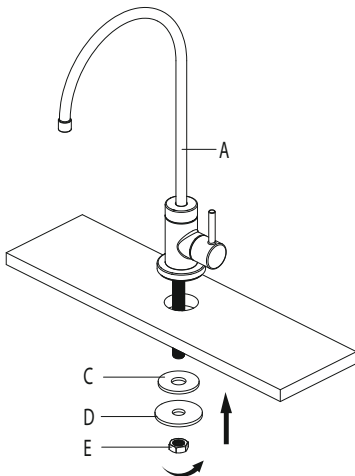
Step 1: Preparing for installation

Remove the rubber washer (C), metal washer (D), and mounting nut (E) from the end of the stud.

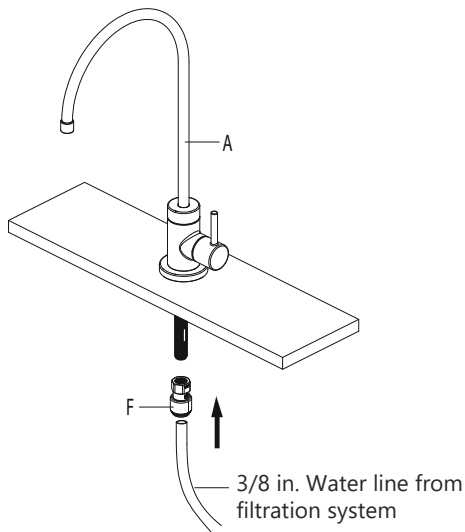


Step 2: Installing the faucet assembly

Place the faucet assembly (A) through the selected hole in the sink or countertop. On the underside of the sink or countertop, slide the rubber washer (C) and metal washer (D) onto the stud. Thread the mounting nut (E) onto the stud, and tighten securely using your wrench.

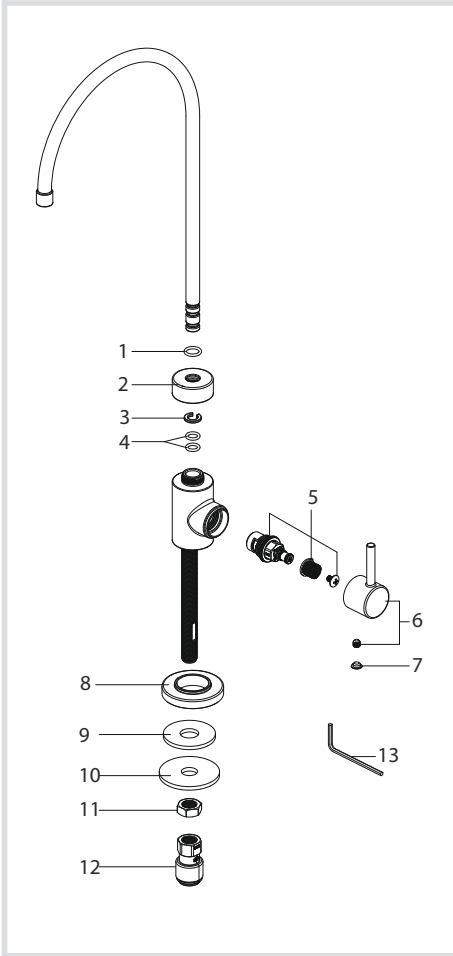


Step 3: Connecting the quick connect adaptor and water line



Thread the quick connect adaptor (F) onto the end of the faucet assembly (A) stud, and tighten securely using a wrench. Connect the 3/8 in. water line from the filtration system by pushing the line into the connector (F). Pull down on the 3/8 in. line slightly to ensure the quick connect fitting has engaged.

Replacement Parts



Replacement Parts List	Finish / Color	Part #
1. O-ring		KP27168
2. Spout Nut	CH, SFS, MB, BG, BB, SFACB, SFSB*	KP27169
3. Locking Ring		KP27170
4. O-ring		KP27171
5. Cartridge		KP27172
6. Handle	CH, SFS, MB, BG, BB, SFACB, SFSB*	KP27173
7. Index	GR, BL*	KP27194
8. Flange	CH, SFS, MB, BG, BB, SFACB, SFSB*	KP27174
9. Rubber Washer		KP27175
10. Metal Washer		KP27176
11. Mounting Nut		KP27177
12. Connector		KP27178
13. Hex Wrench		KP27020

*Denotes faucet component color options:

CH - Chrome

SFS - Spot Free Stainless Steel

MB - Matte Black

BG - Brushed Gold

BB - Brushed Brass

SFACB - Spot Free Antique Champagne Bronze

SFSB - Spot Free Black Stainless

SFSMB - Spot Free Stainless Steel/Matte Black

BBMB - Brushed Brass/Matte Black

GR - Grey

BL - Black

Troubleshooting

If you have followed the instructions carefully and your faucet still does not work properly, take the following corrective steps:

PROBLEM	CAUSE	ACTION
Leakage under the handle	Cartridge (5) has come loose	Remove index (7) and loosen set screw with hex wrench (13). Remove the handle. Tighten cartridge (5) with an adjustable wrench.
Water will not shut off completely.	Cartridge may need to be adjusted or replaced.	Remove index (7) and loosen set screw with hex wrench (13). Remove the handle. Loosen the cartridge (5) with an adjustable wrench. Remove the cartridge (5). Check for cracks.

Codes/Standards Applicable:



NSF/ANSI 61



ASME A112.18.1
1GPM 3.8L/min maximum

Faucet - Lifetime Limited Warranty

Kraus® USA Plumbing, LLC ("Kraus") extends this warranty to the original purchaser for personal household use of the Faucet when purchased from an authorized Kraus dealer and in the location of original installation. This warranty is non-transferable.

Kraus warrants the structure and finish of the Faucet to be free from defects in material and workmanship under normal usage for as long as the original purchaser resides in the residence in which the Faucet was first installed.

Kraus warrants the Faucet's sprayhead assembly (including the engine, aerators, structure, restrictors, back flow preventers, sprayer hoses, braided supply line hoses which encompasses nylon, silicon and stainless steel) of the product to be free from defects in material and workmanship under normal usage for a period of one (1) year from the date of purchase.

Kraus warrants the Faucet's cartridge to be free from defects in material and workmanship under normal usage for a period of five (5) years from the date of purchase.

Any product reported to the authorized dealer or to Kraus as being defective within the warranty period will be repaired or replaced with a product of equal value at the option of Kraus.

Commercial Warranty

Kraus USA Plumbing, LLC ("Kraus") warrants its Products for a period of one (1) year to commercial purchasers of Products used in industrial, commercial and business applications.

Care and Cleaning Instructions

Certain cleaning products may cause damage to a Product's finish and use of the following on the Product will void this warranty:

- Abrasive cleaners such as powders, bleach, ammonia, alcohol or chlorine
- Abrasive pads, steel wool or wire brushes

What is Not Covered

This warranty does not cover Products that were discontinued when purchased or display Products, whether such Products were purchased at discount outlets, unauthorized dealers, and/or sold on clearance. This warranty does not cover any free gifts included with purchase.

This warranty does not cover damage resulting from neglect, misuse (including use for an unintended application), abuse, carelessness, accident, hard water or mineral deposits, exposure to corrosive materials, improper maintenance, alteration of the Product, or failure to follow care, cleaning or installation instructions enclosed with your Product. Kraus recommends that all Kraus Products be installed by a fully licensed and insured trade professional with experience in the installation of bathroom and/or kitchen manufactured goods.

How to Make a Warranty Claim

If you are a **consumer purchaser**, please contact a Kraus® Customer Service Representative at:
Kraus USA Plumbing, LLC
12 Harbor Park Drive
Port Washington, NY 11050
Toll-free 800-775-0703
Customerservice@kraususa.com

If you are a **plumbing contractor or trade professional**, please contact a Kraus Pro Representative at:
Kraus USA Plumbing, LLC
12 Harbor Park Drive
Port Washington, NY 11050
516-801-8955
Proservice@kraususa.com

If you are an **authorized partner**, please contact a Partner Support Representative at:
Kraus USA Plumbing, LLC
12 Harbor Park Drive
Port Washington, NY 11050
516-801-8954
Partnersupport@kraususa.com

In requesting warranty service, please be ready to provide your proof of purchase and a description of the problem. Shipping charges will be covered for the first (1) year of the warranted replacement part or product (HI, AK, and Puerto Rico shipping charges may apply). International shipping fees are not included.

Limitation on Duration of Implied Warranties

Please note that some states/provinces (including Quebec) do not allow limitations on how long an implied warranty lasts, so the below limitations may not apply to you. TO THE MAXIMUM EXTENT PERMITTED BY APPLICABLE LAW, ANY IMPLIED WARRANTY, INCLUDING THE IMPLIED WARRANTIES OF MERCHANTABILITY AND OF FITNESS FOR A PARTICULAR PURPOSE, IS LIMITED TO THE STATUTORY PERIOD OR THE DURATION OF THIS WARRANTY, WHICHEVER IS SHORTER.

Limitation of Special, Incidental or Consequential Damages

Please note that some states/provinces (including Quebec) do not allow the exclusion or limitation of special, incidental or consequential damages, so the below limitations and exclusions may not apply to you. TO THE MAXIMUM EXTENT PERMITTED BY APPLICABLE LAW, THIS WARRANTY DOES NOT COVER, AND KRAUS USA PLUMBING, LLC SHALL NOT BE LIABLE FOR, ANY SPECIAL, INCIDENTAL OR CONSEQUENTIAL DAMAGES (INCLUDING LABOR CHARGES TO REPAIR, REPLACE, INSTALL OR REMOVE THIS PRODUCT), WHETHER ARISING OUT OF BREACH OF ANY EXPRESS OR IMPLIED WARRANTY, BREACH OF CONTRACT, TORT, OR OTHERWISE.

This warranty gives you specific legal rights, and you may also have other rights which vary from state/province to state/province.

Download the Kraus Care & Maintenance Guide at:
<http://www.kraususa.com/maintenance>

IMPORTANT

Register Your Kraus Product

Activate Your Warranty

Access Premium Customer Support

Get Product Information

REGISTER TODAY

<http://www.kraususa.com/registration>



Kräus[®]
www.kraususa.com