

INSTALLATION INSTRUCTIONS UNDERMOUNT SINKS

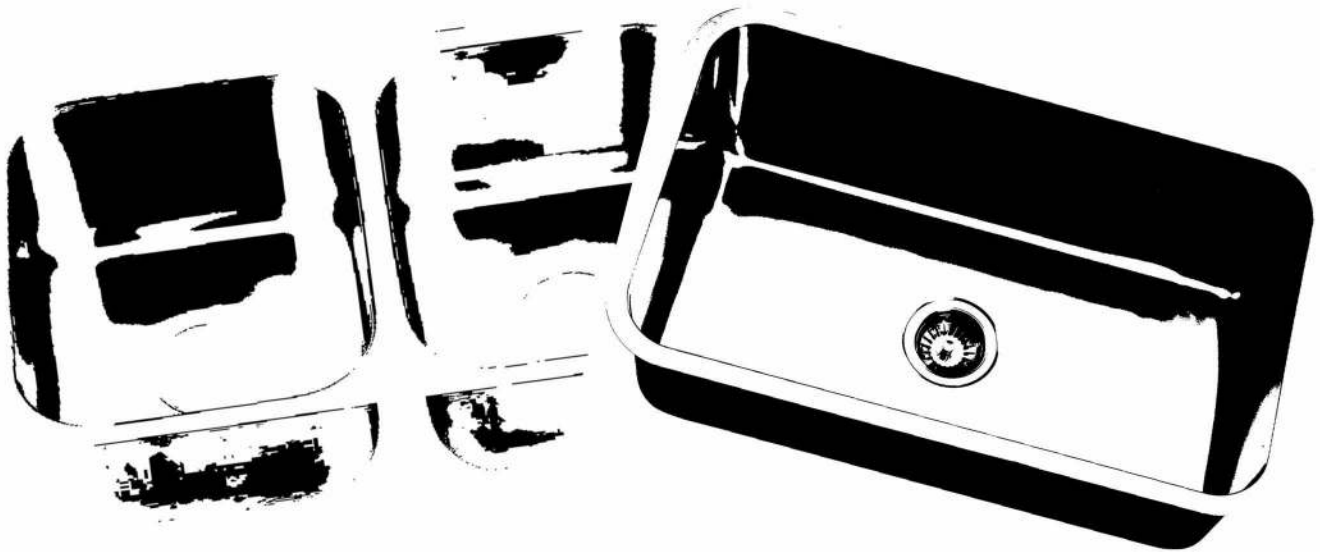

These instructions are for installing *Dawn.* undermount sinks.
Please read all instructions carefully before starting the installation.

TABLE OF CONTENTS

Preparation	2
Materials & Tools	2
Installation	3
Maintenance	5
Return Policy	6
Asking for Assistance	6



**UNDERMOUNT SINKS
INSTALLATION INSTRUCTIONS**

PREPARATION

● **Before You Begin**

Before installing any Dawn product in your new or remodeled kitchen, you should make sure that you are in compliance with all local plumbing codes.

● **Check The Accessory Items**

Before installation, please check the condition of the product and, if appropriate, its components. If there is any problem with the product and/or its components, please contact the store you purchased it from for a replacement. As soon as you have inspected your product, please return it to its original packaging until you are ready to install it.

● **Handle With Care**

Your stainless steel sink may be very heavy and may possibly require more than one person to lift it. To protect its finish and avoid damage before and after installation, please handle your sink with care. For care and cleaning tips on Dawn Stainless Steel Sinks after installation, please refer to the *Maintenance* part in this instruction guide.

MATERIALS & TOOLS

Sink Template supplied by Dawn
Eye Protection (Safety Glasses)
Ear Protection
Framing Square
Pencil
Silicone Adhesive Sealant
Stone Epoxy
Tape Measure
Jigsaw or Hacksaw and Blades
Rags
Denatured Alcohol
Other tools as needed

**UNDERMOUNT SINKS
INSTALLATION INSTRUCTIONS**

INSTALLATION

IMPORTANT: Recommended for professional installers only. The installer maintains responsibility for installing the product safely.

● **STEP 1: Create A Template**

Determine and mark the centerline of the sink position and alignment with cabinet and countertop. Plan for adequate clearance between the faucet holes and the countertop backsplash or finished wall. To create a template, first use the framing square to draw a centerline on the plywood subcounter. Then, place the cardboard template included in the Dawn Undermount Sink Package and draw the template line. Make sure the template line is even.

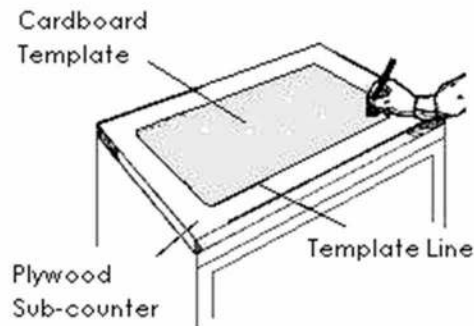

NOTE: Cardboard templates are supplied only as a guide. The actual use of sink provides more accurate cutout.

Drill a hole on the inside of the template line. Insert the saw blade into the hole and cut out the plywood template along the template line.

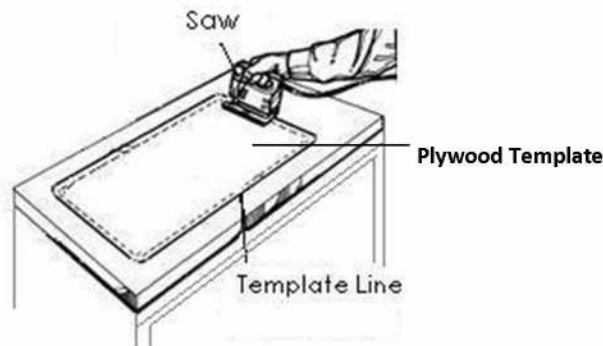

● **STEP 2: Make The Sink Cutout**

Secure the plywood template to the solid surface countertop in desired position. Then, place the saw over the plywood template and cut the countertop around it. Make sure your saw cuts along the edge of the plywood template. This creates the sink cutout on the countertop.

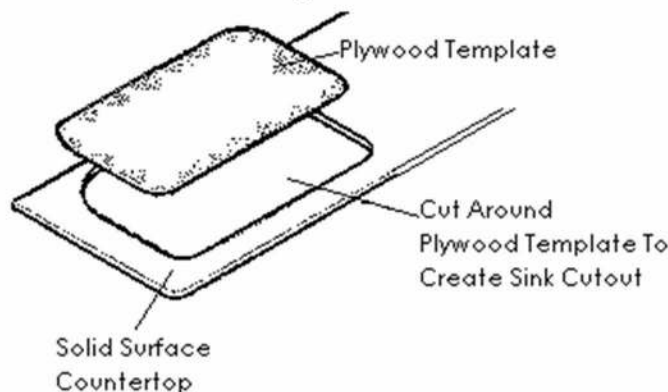

**UNDERMOUNT SINKS
INSTALLATION INSTRUCTIONS**

INSTALLATION

IMPORTANT: Recommended for professional installers only. The installer maintains responsibility for installing the product safely.

● **STEP 3: Install The Undermount Sink**

Position the sink into the cabinet and align the sink to the cutout opening. Press the sink against the plywood sub-counter and make sure the sink is well supported. Verify the sink is level both front to back and left to right. Adjust the sink position as needed.

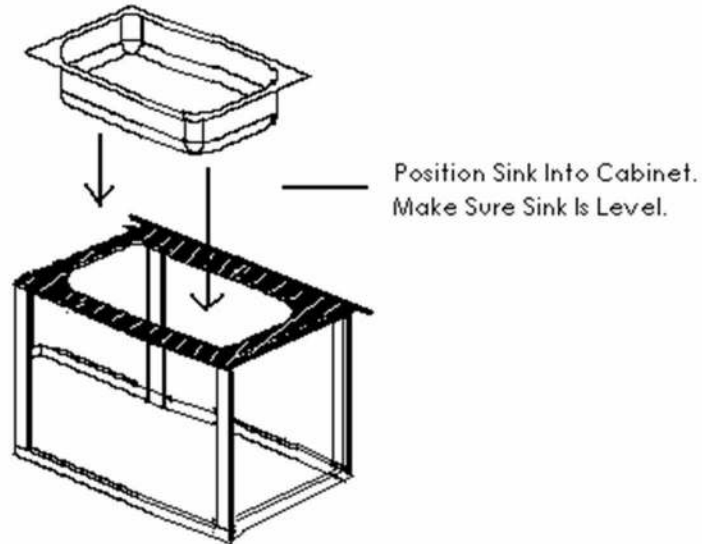

● **STEP 4: Install The Countertop**

Clean the bottom of the countertop and the sink flange with denatured alcohol. Apply a thin bead of silicone sealant on the sink flange where the countertop meets the sink. Also apply enough amount of stone epoxy on the plywood to adhere to the countertop. Immediately wipe away any excess sealant with a damp cloth.

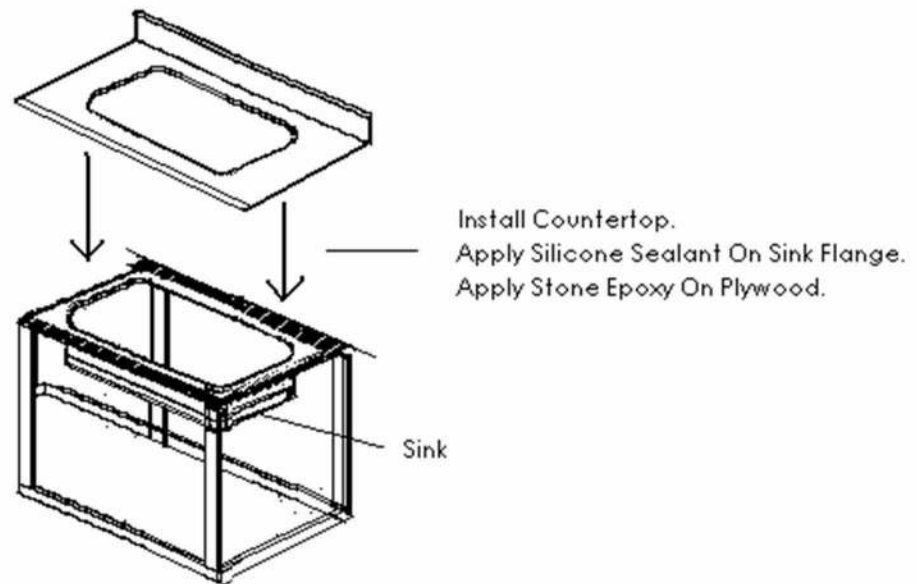

● **STEP 5: Clean Up**

After completing the installation of the undermount sink, please follow the maintenance tips provided in this instruction guide.

UNDERMOUNT SINKS INSTALLATION INSTRUCTIONS

MAINTENANCE

Care and cleaning instructions for Dawn stainless steel sinks:

Clean regularly with clean water and/or a mild detergent solution applied with a soft cloth or sponge. Rinse thoroughly and towel dry after every use to prevent water spots and mineral deposits from building up on the surface of the sink. Deep clean once a week with an approved cleanser and a soft cloth or sponge rather than an occasional aggressive single cleaning - be sure to rub in the direction of the finish lines. Cleaners should state approved or suitable for stainless steel.

- **Scratches**
Like most metallic surfaces, stainless sinks will get scratches. These are usage scratches and will blend in with the overall finish of your sink over time. There are steps that can be taken to reduce appearance of scratches:
Use a nylon pad with an iron free abrasive polishing compound. Follow the direction of the original polish lines to blend out the scratch in a small area. Be cautious not to overdo the process. A too aggressive procedure will result in a bright spot.
- **Water Quality**
Regular routine cleaning can usually prevent lime scale deposits from hard water. Do not allow excessive build up before treating. Soaking in a 25% vinegar solution can treat hard water spots. Periodically rub with a synthetic scouring pad, then rinse and towel dry.
- **Rust Marks**
If you develop rust marks due to presence of or contact with iron containing materials, swab with a sponge wetted with a dilute solution of (10-15%) nitric acid (HN03) and follow with routine cleaning. Avoid prolonged contact of iron containing materials with stainless steel.

Do's and Don'ts

- Do regular routine cleaning rather than an occasional aggressive single cleaning.
- Only use propriety brands of cleaners that state "SUITABLE FOR STAINLESS STEEL".
- Always rinse and dry as the final step in a cleaning procedure.
- If there is any accidental contact of the sink with photographic chemicals or soldering fluxes, immediately rinse and clean the sink with water.
- Do not leave low-carbon steel or iron kitchenware in the sink.
- Do not leave rubber patches, wet sponges, cloths, cleaning pads, or dishpans in the sink.
- Do not use coarse abrasive powders, metallic scourers such as steel wool or brushes with metal bristles.
- Do not leave standing solutions of chlorine bleach and water in the sink.
- Do not allow liquid soap or other cleansers to dry on the surface of the sink.
- Do not leave food with high-salt content such as pickles, béarnaise sauce or mustard in the sink.
- Do not use cleaning products containing silver, sulfur or hydrochloric acid.
- Do not leave metal or rusted materials in the sink.
- Do not rub the sink with metal rubbing or scrubbing pads.
- Do not use the sink as a cutting board.

LEGAL DISCLAIMER:

- This instruction guide is done as a public service to customers of Dawn Kitchen & Bath Products, Inc. ("Dawn"). For special situations or further assistance, please consult professionals.
- All products should be inspected by customers upon receipt and before any preparation for installation. Any defective product should be reported immediately and should NOT be installed.
- Requirements may vary for installation in a granite, marble, stone, or butcher block countertop.
- Installation by professional installers is highly recommended. Dawn assumes no liability for any damages incurred through the use of information provided in this publication or the installation.



UNDERMOUNT SINKS
INSTALLATION INSTRUCTIONS

WARRANTY

All Dawn products have been manufactured and tested to the highest quality standards by Dawn Kitchen & Bath Products, Inc. ("Dawn"). This warranty is limited to Dawn products purchased and installed in the United States. Dawn Kitchen & Bath Products, Inc. warrants its products to be free from manufacturing defects in material and workmanship during normal residential use for as long as the original consumer purchaser owns his or her home. This warranty only extends to the original consumer purchaser and this warranty is non-transferable. If any defect is found in normal residential use, Dawn Kitchen & Bath Products, Inc. will, at its election, repair, provide a replacement part of product, or make appropriate adjustment at no charge (excluding labor charges and other incidental or consequential costs). Damage to a product caused by accident, misuse, or abuse is NOT covered by this warranty. Improper care and cleaning will void the warranty. If Dawn is unable to provide a replacement and repair cannot be made, Dawn may elect to refund the purchase price to the original consumer purchaser in exchange for the return of the product. (IMPORTANT: The original consumer purchaser should be responsible for inspecting products upon receipt. Any defective product should be reported immediately and should NOT be installed.)

THIS WARRANTY DOES NOT COVER, AND DAWN DISCALIMS ANY LIABILITY FOR:

- Conditions or damage NOT resulting from defects in material or workmanship.
- Conditions or damage resulting from
 - ① normal wear and tear, improper installation, improper maintenance, misuse, abuse, negligence, accident or alteration, or
 - ② the use of abrasive cleaning products or the use of the product in any manner contrary to the product instructions, or
 - ③ conditions in the home such as excessive water pressure or corrosion.
- Labor, shipping, or other costs for the disconnection, deinstallation, or return of the product for warranty service, or costs for installation or reinstallation of the product.
- Parts, accessories, connected materials, or related products not manufactured by Dawn.

Dawn reserves the right to inspect any Dawn product reported to be defective prior to any repair or replacement. Repair and replacement costs EXCLUDE shipping, labor, and consequential expenses. To request warranty service, please contact Dawn Customer Service at toll-free 1-877-Dawn-USA. NOTE: Proof of purchase (original sales receipt) and description of problem must be provided with all warranty claims.

RETURN POLICY

You may only return new, uninstalled, or unused items sold and fulfilled by Dawn Kitchen & Bath Products, Inc. for a full refund within 30 days of delivery. Items must be returned in its original package. Returns of used items or returns after 30 days of delivery may be accepted with a 15% restocking fee. Dawn will pay for return shipping costs only if the return is a result of our fault. If you receive a faulty product and need to exchange it for the same product, please contact our customer service via phone, fax, or e-mail to request a replacement. If you would like to exchange a product for a different one, please first return the original product to our location at 27688 Industrial Blvd., Hayward, CA 94545 and then place a new order.

PARTIAL REFUNDS MAY BE GIVEN TO:

- Most of the items that are returned after 30 days of delivery
- Any item not returned in the condition it was delivered
- Any item that has obvious signs of use
- A 15% restocking fee will apply to all used items or items returned after 30 days of delivery.

ASKING FOR ASSISTANCE

Customer Service Department
Dawn Kitchen & Bath Products, Inc.
27688 Industrial Blvd., Hayward, CA 94545
Toll-Free: 877-DAWN-USA (877-329-6872)
Tel: 510-723-0088 Fax: 510-723-0099
E-mail: dp@dawnusa.net Web: www.dawnusa.net