

**GRAYSON
57" CAST IRON
SLIPPER TUB**

Cat. No.
CTSN57



L: 57 3/8"
W: 29 1/2"
H: 22 3/4" & 30" (from floor to top of tub)
16 1/2" & 23 3/4" (from bottom of tub to top of tub)

Depth: 13 1/2" to overflow
16 1/2" at drain

Overflow hole" 1 1/2" diameter

The following is recommended for CTSN57 tubs without deck holes:

- Faucets: part #4602
- Rigid, freestanding supplies: part #4502
- Leg tub drain: part #5599

Gallon Capacity: 35
Shipping Weight: 455 lbs.
Empty Weight: 275 lbs.
Filled Weight: 567 lbs.

Features:

- ▶ Inside finish is white enamel
- ▶ Ball and claw reet available in 6 finishes
- ▶ Tub exterior is white (epoxy)
- ▶ No faucet holes
- ▶ Feet are attached and leveled before shipment
- ▶ Tub is thoroughly inspected before shipment

Foot Finishes:

BP Polished Brass **SN** Brushed Nickel
CP Polished Chrome **WH** White
PN Polished Nickel **ORB** Oil-rubbed Bronze

Extra Paint Charge (inside of tub is always white enamel):
Bisque Paint - \$160 **Black Paint** - \$160
Bathtubs painted in bisque or black are considered "special order" and are not returnable.

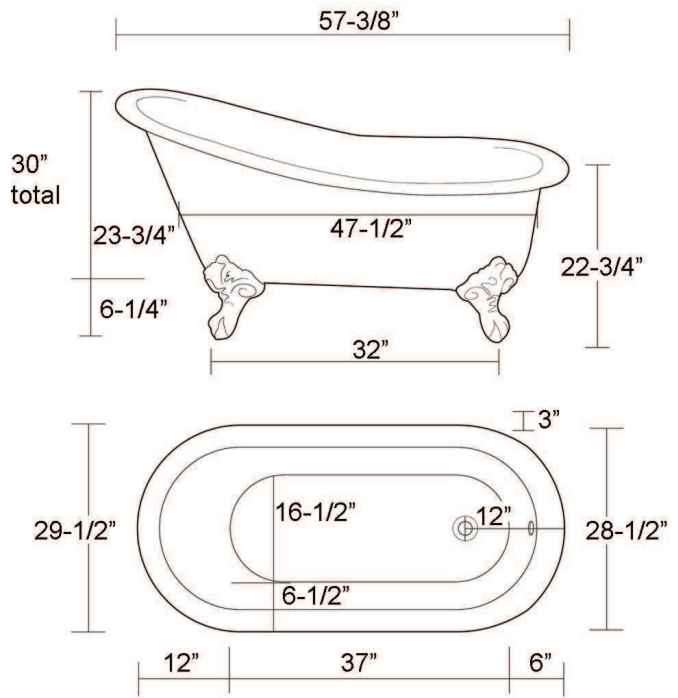

Dimensions of fixture are nominal and may vary within the range of tolerances established by ANSI Standard A112.19.1M. Dimensions and specifications subject to change without notice.