

48" CAST IRON ROLL TOP TUB

Cat. No.
CTRH49



L: 48"
W: 30"
H: 20 1/2" (from floor to top of tub)

Depth: 12" to overflow
14 1/2" at drain

Overflow hole: 1 1/2" diameter

The following is recommended for CTRH49 tubs with faucet holes:

- Tub wall-mounted faucets or hand-held showers: part# **4022, 4025, 4035**
- Tub wall-mounted faucets for use with risers: part# **4001, 4013, 4023, 4030, 4031**
- Double offset bath supplies: part #**5576**
- Leg tub drain: part #**5599**
- Complete shower unit: part# **4124, 4143**

Gallon Capacity: 29
Shipping Weight: 413 lbs.
Empty Weight: 233 lbs.
Filled Weight: 484 lbs.

Features:

- ▶ Inside finish is white enamel
- ▶ Ball and claw feet available in 6 finishes
- ▶ Tub exterior is enamel
- ▶ 3 3/8" centers in tub wall
- ▶ Feet are attached and leveled before shipment
- ▶ Tub is thoroughly inspected before shipment

Foot Finishes:

BP Polished Brass **SN** Brushed Nickel
CP Polished Chrome **ORB** Oil-Rubbed Bronze
PN Polished Nickel **WH** White

Extra Paint Charge (inside of tub is always white enamel):
Bisque Paint - \$160 **Black Paint** - \$160
Bathtubs painted in bisque or black are considered "special order" and are not returnable.

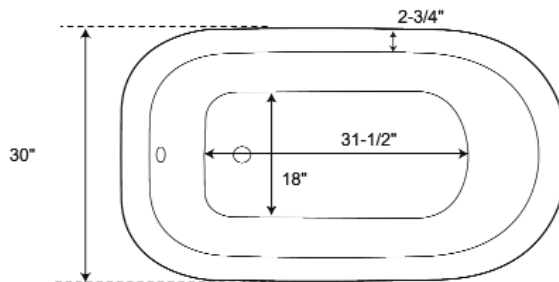
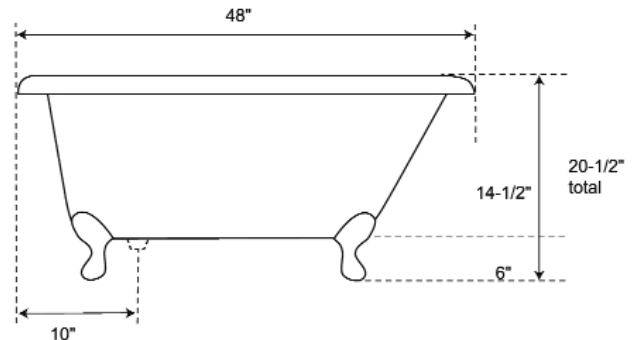

Dimensions of fixture are nominal and may vary within the range of tolerances established by ANSI Standard A112.19.2. Dimensions and specifications subject to change without notice.