

**RANDALL  
74" CAST IRON  
DOUBLE SLIPPER TUB**

Cat. No.  
CTDSN74B-WH



L: 73 1/4"  
W: 30"  
H: 24 3/4" and 29" (from floor to top of tub)

Water depth: 13 1/2" to overflow

**The following is recommended for CTDSN74B tubs:**

- Faucet: part #4602, 7393 or 7410
- Rigid, freestanding supplies: part #4502
- Leg tub drain: part #5599

Gallon Capacity:	53
Shipping Weight:	565 lbs.
Empty Weight:	340 lbs.
Filled Weight:	783 lbs.

**Features:**

- ▶ Inside finish is white enamel
- ▶ Tub is on cast iron pedestal
- ▶ Tub exterior is white (epoxy)
- ▶ No faucet holes with a continuous rolled rim
- ▶ Tub is thoroughly inspected before shipment

**Extra Paint Charge** (inside of tub is always white enamel):  
**Bisque Paint** - \$160                      **Black Paint** - \$160  
 Bathtubs painted in bisque or black are considered "special order" and are not returnable.

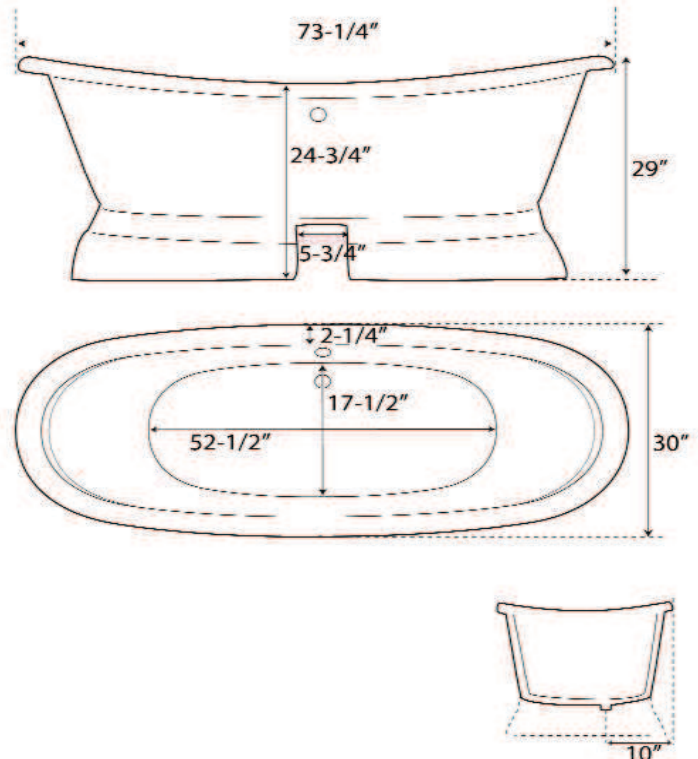

Dimensions of fixture are nominal and may vary within the range of tolerances established by ANSI Standard A112.19.2. Dimensions and specifications subject to change without notice.