

**NELSON  
73" CAST IRON  
DOUBLE SLIPPER TUB**

Cat. No.  
CTDSN73L



L: 73"  
W: 30"  
H: 28 7/8" (from floor to top of tub)

Water depth: 13 3/4" to overflow

**The following is recommended for CTDSN73L tubs:**

- Faucet: part #4602
- Rigid, freestanding supplies: part #4502
- Leg tub drain: part #5599

Gallon Capacity:	57
Shipping Weight:	525 lbs.
Empty Weight:	300 lbs.
Filled Weight:	776 lbs.

**Features:**

- ▶ Inside finish is white enamel
- ▶ Imperial feet available in 4 finishes
- ▶ Tub exterior is white (epoxy)
- ▶ No faucet holes
- ▶ Feet are attached and leveled before shipment
- ▶ Tub is thoroughly inspected before shipment

**Foot Finishes:**

**BP** Polished Brass      **SN** Brushed Nickel  
**CP** Polished Chrome  
**ORB** Oil-rubbed Bronze

**Extra Paint Charge** (inside of tub is always white enamel):  
**Bisque Paint** - \$160                      **Black Paint** - \$160  
 Bathtubs painted in bisque or black are considered "special order" and are not returnable.

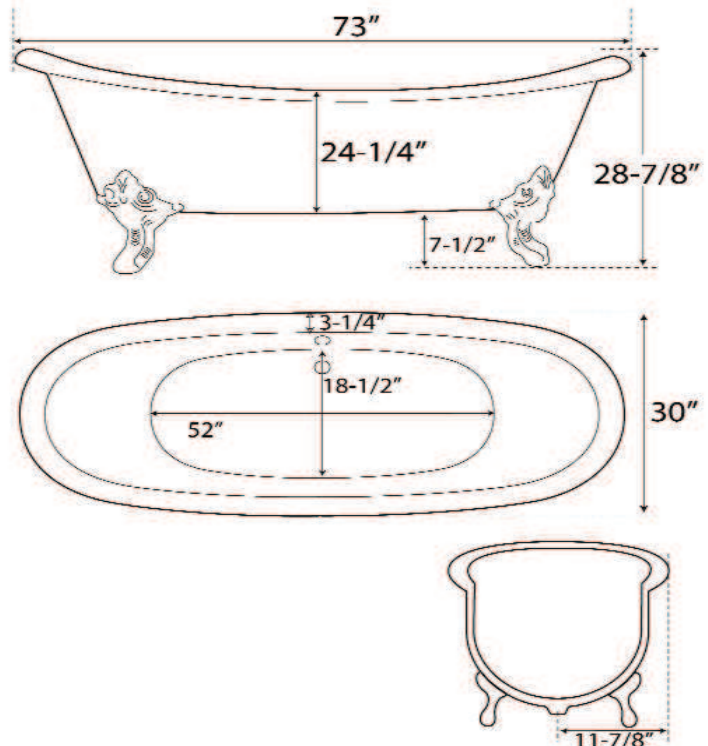

Dimensions of fixture are nominal and may vary within the range of tolerances established by ANSI Standard A112.19.2. Dimensions and specifications subject to change without notice.