

**DAWSON  
61" CAST IRON  
DOUBLE ROLL TUB**

Cat. No.  
CTDRN61LP



L: 60 3/4"  
W: 30 3/8"  
H: 23 7/8" (from floor to top of tub)

Water depth: 14 1/2" to overflow

**The following is recommended for CTDRN61LP tubs:**

- Faucet: part #4602, 7393 or 7410
- Rigid, freestanding supplies: part #4502
- Leg tub drain: part #5599

Gallon Capacity: 30  
Shipping Weight: 450 lbs.  
Empty Weight: 270 lbs.  
Filled Weight: 521 lbs.

**Features:**

- ▶ Inside finish is white enamel
- ▶ Elegant lion paw feet available in 5 finishes
- ▶ Tub exterior is white (epoxy)
- ▶ No faucet holes
- ▶ Feet are attached and leveled before shipment
- ▶ Tub is thoroughly inspected before shipment

**Foot Finishes:**

- BP** Polished Brass
- CP** Polished Chrome
- ORB** Oil-rubbed Bronze
- SN** Brushed Nickel
- WH** White

**Extra Paint Charge** (inside of tub is always white enamel):  
**Bisque Paint** - \$160                      **Black Paint** - \$160  
 Bathtubs painted in bisque or black are considered "special order" and are not returnable.

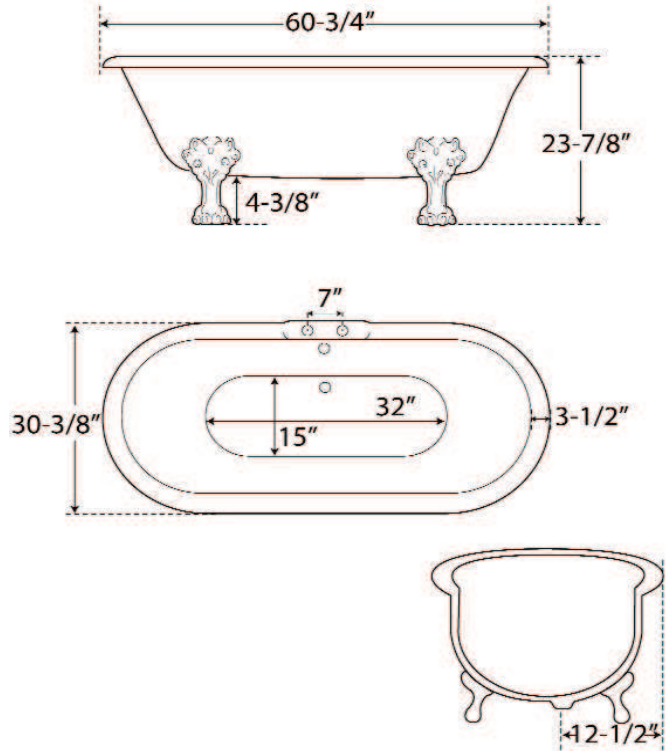

Dimensions of fixture are nominal and may vary within the range of tolerances established by ANSI Standard A112.19.2. Dimensions and specifications subject to change without notice.