

# 60" CAST IRON DOUBLE ROLL TOP TUB

Cat. No.  
CTDRN60B



L: 60"  
W: 30"  
H: 23 3/4" (from floor to top of tub)

Depth: 13" to overflow  
17 3/4" at drain

**The following is recommended for CTDRN tubs without faucet holes:**

- Faucets: part #4602
- Rigid, freestanding supplies: part #4502
- Leg tub drain: part #5599

Gallon Capacity: 32  
Shipping Weight: 520 lbs.  
Empty Weight: 340 lbs.  
Filled Weight: 607 lbs.

## Features:

- ▶ Inside finish is white enamel
- ▶ One piece tub with integrated base
- ▶ Tub exterior is white (expoxy)
- ▶ No faucet holes
- ▶ Continuous rolled rim
- ▶ Tub is thoroughly inspected before shipment

**Extra Paint Charge** (inside of tub is always white enamel):  
**Bisque Paint** - \$160                      **Black Paint** - \$160  
Bathtubs painted in bisque or black are considered "special order" and are not returnable.

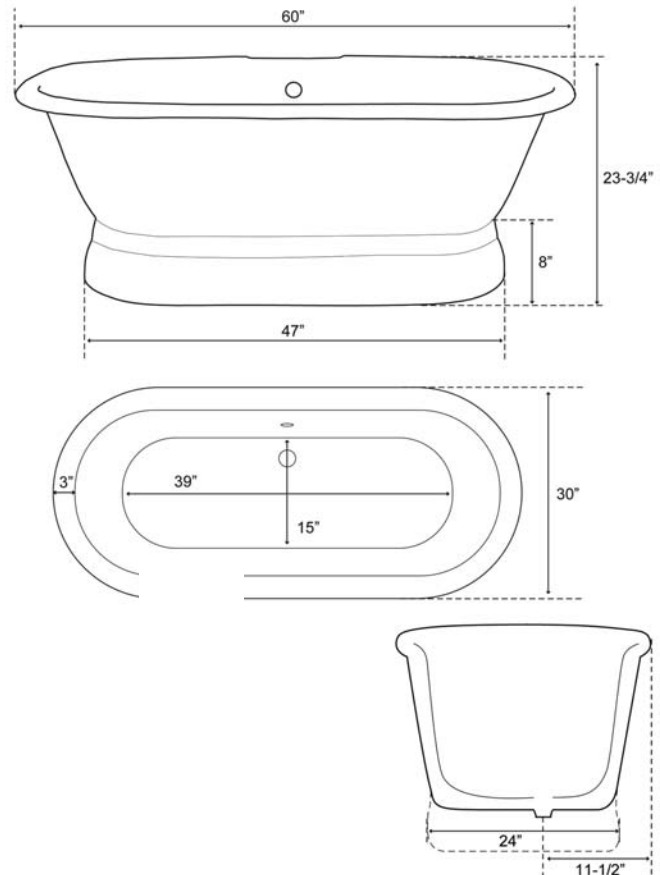

Dimensions of fixture are nominal and may vary within the range of tolerances established by ANSI Standard A112.19.2. Dimensions and specifications subject to change without notice.