

**FERNANDO
67" CAST IRON
DOUBLE ROLL TUB**

Cat. No.
CTBATN67MS



L: 67"
W: 26 5/8"
H: 28" (from floor to top of tub)

Water depth: 13" to overflow

The following is recommended for CTBAT67MS tubs:

- Faucet: part #4602, 7393 or 7410
- Rigid, freestanding supplies: part #4502
- Leg tub drain: part #5599

Gallon Capacity:	35
Shipping Weight:	504 lbs.
Empty Weight:	324 lbs.
Filled Weight:	617 lbs.

Features:

- ▶ Inside finish is white enamel
- ▶ Cast iron tub wrapped in gray metal skirt
- ▶ No faucet holes
- ▶ Tub is thoroughly inspected before shipment

Extra Paint Charge (inside of tub is always white enamel):
Bisque Paint - \$160 **Black Paint** - \$160
 Bathtubs painted in bisque or black are considered "special order" and are not returnable.

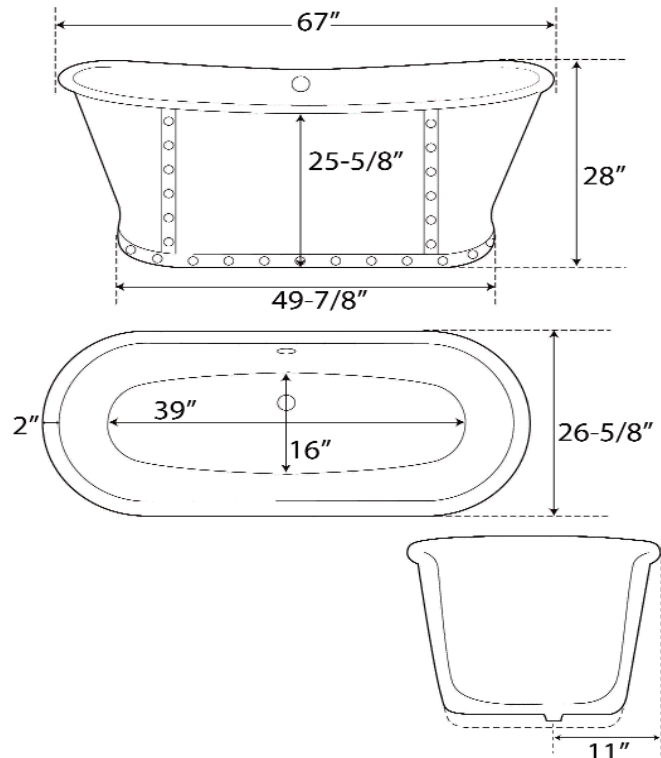

Dimensions of fixture are nominal and may vary within the range of tolerances established by ANSI Standard A112.19.2. Dimensions and specifications subject to change without notice.