

SAUNACORE

INSTALLATION INSTRUCTIONS FOR SAUNACORE KW SAUNA HEATING UNITS & CONTROLS

INSTALLATION GUIDE & OWNERS MANUAL

Saunacore Heaters

This Manual contains installation and operation instructions, specifications, maintenance information, and warranty information

SAUNACORE

Technical Hotline 905-951-6662

www.saunacore.com

ATTENTION: THIS MANUAL MUST REMAIN WITH THE OWNER OR OPERATOR OF THE SAUNA

*Certified to CAN/CSA Std. No. 164
Conforms to UL Std. 875*

Figure 1

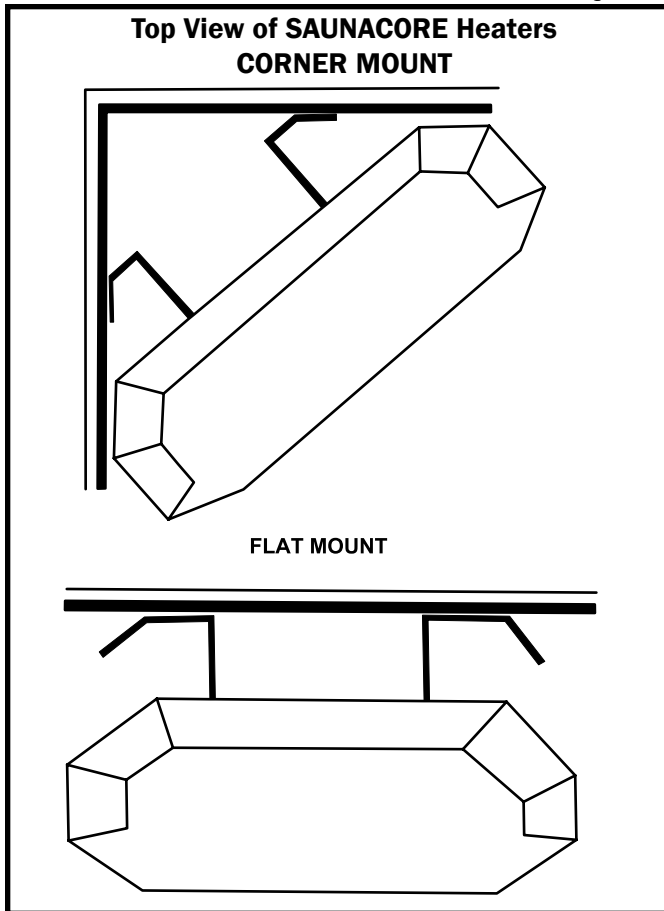

IT IS UNLAWFUL TO INSTALL THIS UNIT WITHOUT FIRST OBTAINING A PERMIT FROM THE LOCAL ELECTRICAL INSPECTION AUTHORITY

Sauna heater controls enclosure box and contactor enclosure box are NOT supplied with the heating units.

Control Box: 3.5" deep x 3.75" high x 5-19/32" wide.
Volume (63 Cu.in.)

Contactor Box: min 6" wide x 6" high x 3" deep
Volume (108 Cu.in.) minimum

All electrical wiring between sauna heater, high power controls, and magnetic contactor must be through a liquidtight metal conduit raceway.

The liquidtight metal conduit must be CSA or UL certified and labelled.
With the following specifications:

105C/221F Dry Temperature Rating
Adequate for 600 volt and lower circuits
Hazardous location per NEC 501
In compliance with UL 360
In accordance with Article 350 of National Electrical Code
CSA/UL Certified & Labelled on Conduit

All saunacore controls must only be used with saunacore sauna heaters. They are certified as a set. If the sauna controls are used with another brand sauna heater, then the control and heater must be re-evaluated.

The total connected load should not be more than 80% of the rating of the overcurrent devices.

INSTALLATION INSTRUCTION FOR ALL SAUNACORE KW HEATING UNITS

SAUNACORE KW is installed in a corner of the Sauna room or on the straight wall by means of two mounting brackets (see illustration).

The unit should be placed 2" inches (minimum) from the floor, and not closer than 45 inches to the ceiling.

Lift the unit 2 inches (minimum) from the floor, hold it against the corner or straight wall and mark the location. Fasten the brackets with 1-1/2" mounting screws supplied. Be sure that the mounting screws are fastened not only through the soft wood lining of the sauna room but also into a solid piece of strapping, 2"x 4" etc., to hold the weight of the unit (approximately 50lbs. with the rocks).

First perform the electrical hook up. CAUTION: This work should be done by a Licensed Electrician. Then slide the unit back onto the brackets. The Saunacore heating units that do not have a control built in should mount the control box on the outside wall of the sauna room beside the door. The thermostat sensor bulb only, is to be located inside the sauna room and is to be mounted on the ceiling above the SAUNACORE heater.

For electrical hook up follow the wiring diagram. This work should be done by a Licensed Electrician only.

Do not install a Showerhead or water spraying device above the heating unit.

All wiring to the SAUNACORE heater must be routed away from any direct radiation from the SAUNACORE Heating unit, and be made with liquid tight conduit.

SAUNA ROCKS (STANDARD, SPECIAL EDITION, STEAM VAPORIZOR MODEL)

After installation of the SAUNACORE Heating unit, carefully place all the igneous Sauna rocks which are supplied onto the rock basket at the top of the sauna stove. Rocks do not make contact with heating element

THIS UNIT MUST BE OPERATED WITH THE ROCKS IN PLACE.

SAUNA ROCKS (Ultimate Models)

Placement of Sauna Rocks

Do not operate the sauna heater without the stones. Use only the stones that are supplied with the sauna heater. Wash stones with water and place them inside of the heater so that rocks are between and around the heating elements onto adjustable tray. Take care, however, not to force the rocks between the elements. Use smaller stones first and continue to fill the heater with larger stones. You may not need all of the stones. Make sure the adjustable rock tray is not lower than level 3 in the heater cavity

STONES SHOULD BE PLACED LOOSELY WITHIN THE HEATER SO THAT THERE IS AMPLE HEAT CIRCULATION AROUND THEM. STONES SHOULD ALSO COVER THE HEATING ELEMENTS COMPLETELY! POURING WATER DIRECTLY ON EXPOSED ELEMENTS COULD GREATLY DECREASE THE LIFE OF THE ELEMENTS!

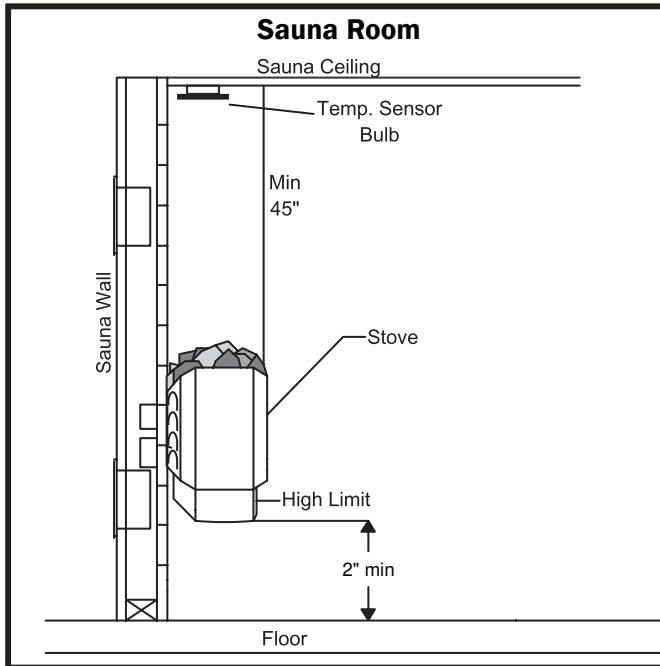

STD, SE, SV, ULT Models

Figure 2

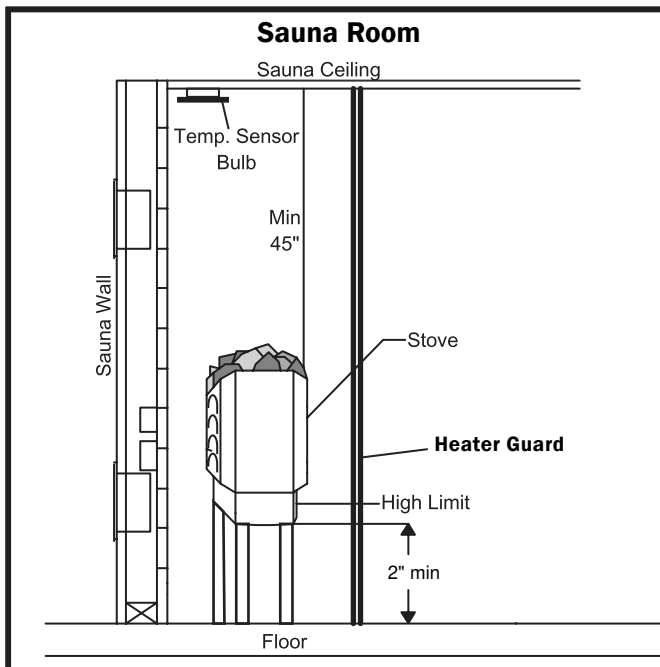

Standard HD & ULT C6 +1
(applies to Canadian application)

Figure 3

Note: Warranty is void on Saunacore heaters and controls if the installer or electrician fails to follow the necessary wiring information as provided in this wiring diagram or fails to follow any and all applicable codes pertaining to the installation of this product.

HEATER GAURD

A non metallic Guard shall be used and located not closer than 6" from the SAUNACORE Heater.

CAUTION

If the manually-resettable Temperature-limiting Control (Hi-Limit) trips frequently, a Qualified Serviceman should be contacted.

TEMP-LIMITING CONTROL

Each heater is equipped with a high limit control switch as a safety device. If an abnormal heating condition should occur, the heater will automatically shut off. The high limit switch will need to be reset manually before the heater will operate. To reset the high limit, locate the reset button (bottom front) and push inward until the contactor engages. If the reset button continues to trip, contact a qualified service person. If using GFI and tripping occurs heater must be operated first with non GFI breaker to bake elements (remove initial moisture that may cause GFI to trip) (Hi-Limit Tripping Cause - Refer to Page 16)

Electrical Outlets

Electrical outlets are not permitted in a sauna room. If speakers are installed in a sauna, they should not be installed higher than 2 feet from the floor and should be located away from the sauna heater.

Heater Guard

A heater guard rail is necessary to protect the sauna bathers from the hot surfaces of the sauna heater. The guard rail should be attached to the wall and should not be placed higher than the top of the heater, below the rock line. STD(HD) & ULTC6 (ED) heater the guard must extend up to ceiling. (Fig 3)

Warnings!

- Do not smoke, use alcohol, or exercise in the sauna.
- Do not exceed 30 minutes in the sauna at one time as excessive exposure can be harmful to your health.
- Persons in poor health should consult a physician prior to using the sauna.
- Do not place any combustible material on or over the sauna heater.
- At no time should towels, bathing suits, buckets or dippers or any other flammable material be placed on or over the heater.
- Use only clean tap water on the sauna stones. Do not use any chemically treated water (such as spa or pool water) on the heater at any time. Use of chemically treated water can result in rapid oxidation of the heater components, voiding warranty.

Saunacore Mercuri sauna controller Installation details.

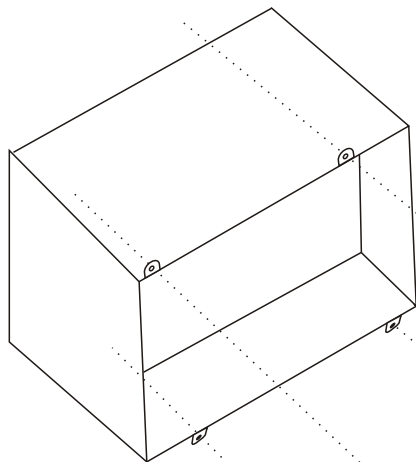

Masonry electrical box.
(Not included in the kit)

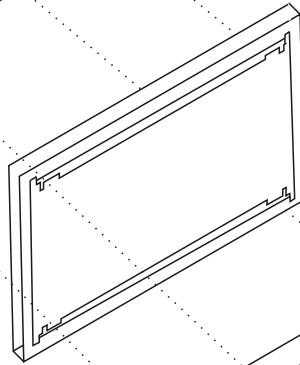

Back frame.
To be placed against the
drywall finish.

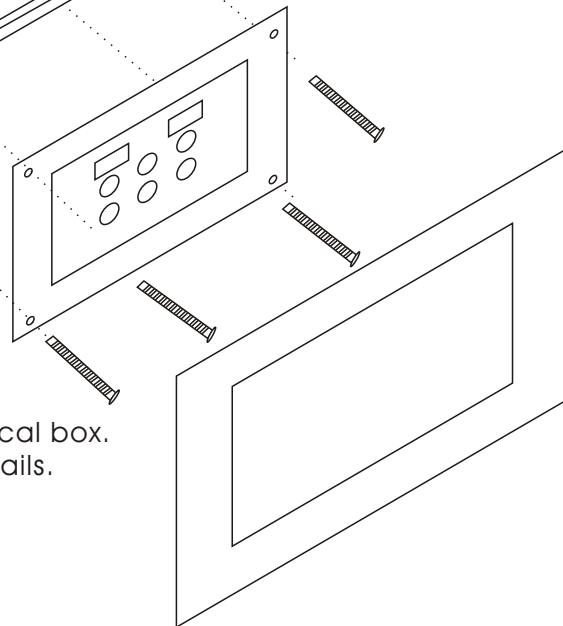

Controller assembly
Use 4 screws (included) to secure to electrical box.
See schematic for connections details.

Front frame
Attached with adhesive tape
(provided).

This control, must be operated only with Saunacore sauna heaters. They are certified as a set.
If this control is used with any other brand heater, then the entire setup and control must be re-evaluated.

When mounting control into metal electrical box, do not force into position. Forcing into position and having excess wiring within the electrical box will put pressure on the back side of the circuit board causing the layers of circuitry to compress and make contact with each other. This will cause malfunction and damage to the sauna control.

Mercuri Digital Control

CAUTION: THE MANUAL RESET LIMIT SHALL BE WIRED IN THE CIRCUIT

Figure 8

For supply connections, use suitable AWG wires suitable for at least 90°C (190°F). (Use only copper wire). Ground wire must be insulated.

Mercuri control must be installed outside of the sauna room, into a 3 gang masonry electrical box.

Box Size: 3.5" deep x 3.75" high x 5-19/32" wide
Volume (63 Cu.in.)

When the magnetic contactor is used, it also must be installed into an appropriate metal electrical enclosure box outside the sauna.

Box Size: min 6" wide x 6" high x 3" deep
Volume (108 Cu.in.)

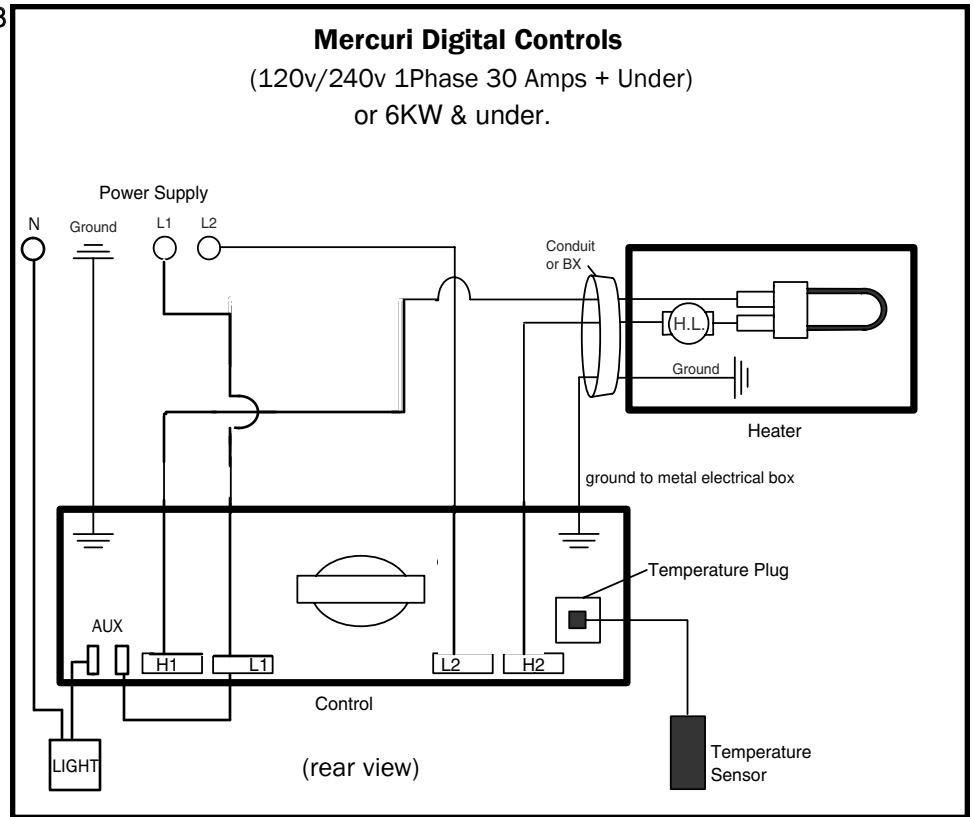

Figure 9

Operation:

Set time and temperature. Temperature display window will alternate simultaneously from current room temperature and set temperature

Note:

All power supply wires from control box to stove must be protected by metal conduit.

Loose connections or connectors may cause electrical shortage. Make sure all connections and connectors are firmly secure.

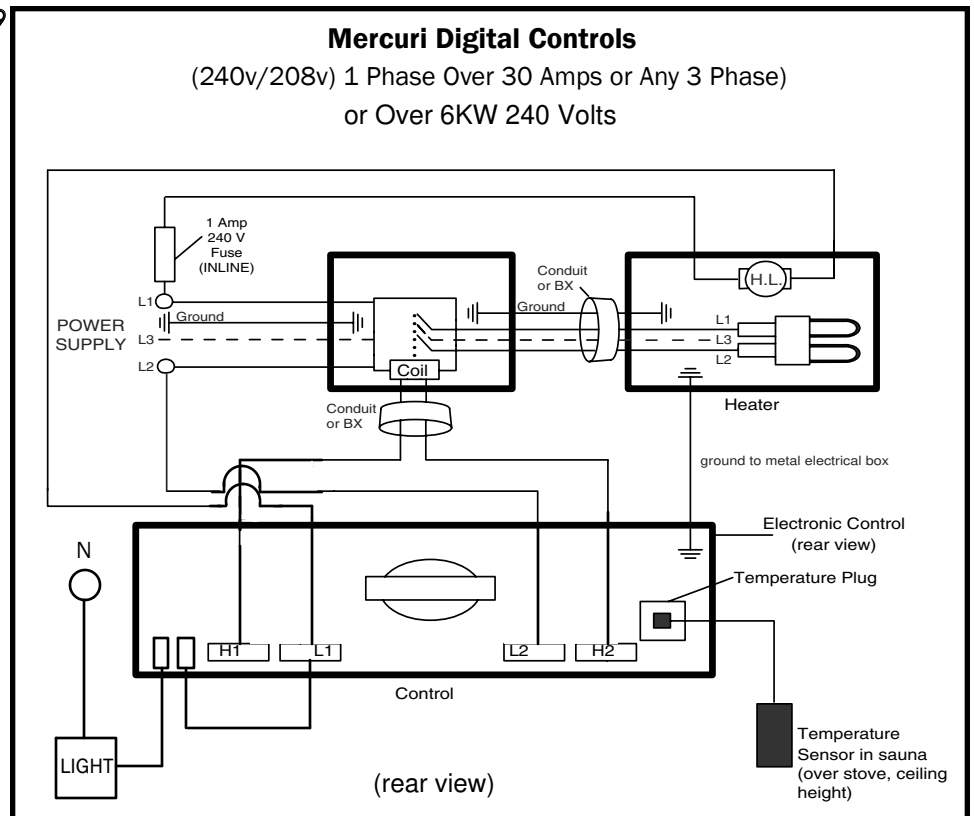

Mercuri Digital Control

Mercuri control must be installed outside of the sauna room, into a 3 gang masonry electrical box. When a magnetic contactor is used, it also must be installed into an appropriate metal electrical enclosure box outside of the sauna.

For supply connections, use suitable AWG wires suitable for at least 90°C (190°F). (Use copper wire only). - Ground wire must be insulated.

Figure 10

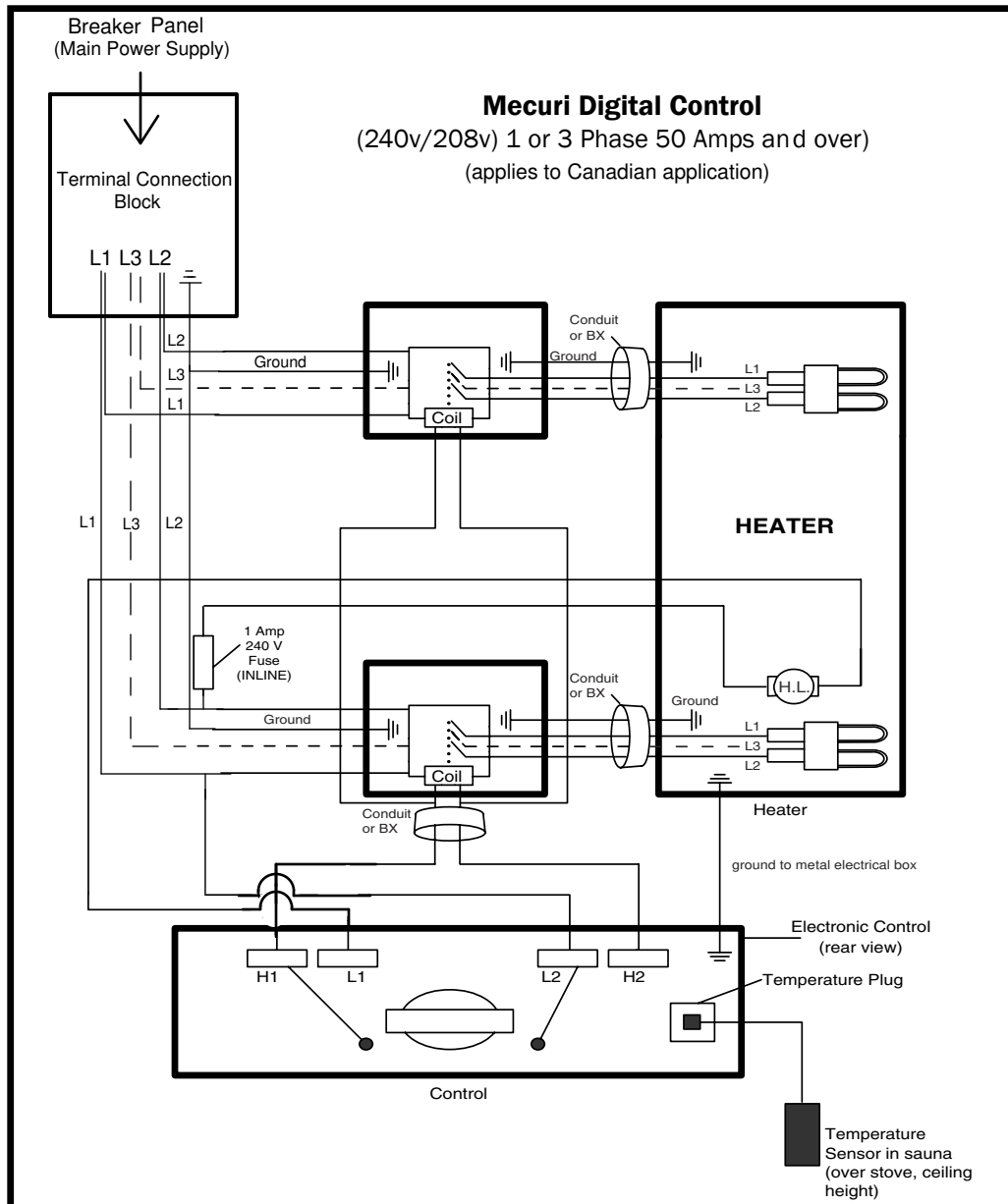

CAUTION: THE MANUAL RESET LIMIT SHALL BE WIRED IN THE CIRCUIT.

Mercuri Digital Sauna Control (by Saunacore)

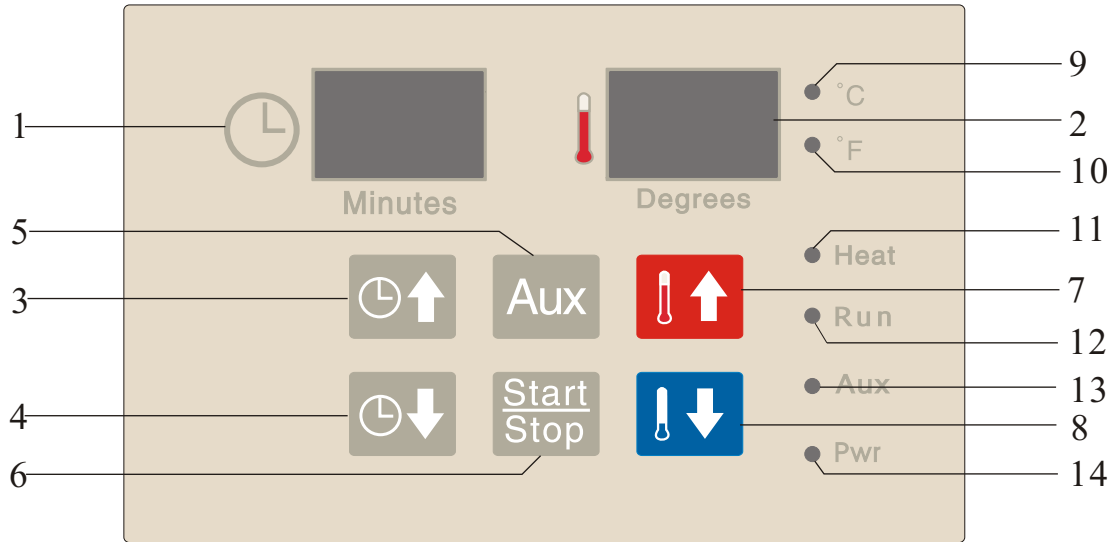

1-----Time display

2-----Temperature display

3-----Time up adjustment

4-----Time down adjustment

5-----Light

6-----Sauna

7-----Tempurature up adjustment

8-----Temperature down adjustment

9-----Temperature is displayed in deg C

10-----Temperature is displayed in deg F

11-----Indicating heater is on

12 -----Sauna is during operation cycle

13-----light is active

14-----Unit is connected to power source

Function

- | | |
|-----------------------------|-------------|
| 1. Light | 2. Sauna |
| 3. Time/Temperature setting | 4. Stand by |

Description

1. Stand-by mode

System power on, heater is in stand-by mode. Power green LED indicator is lit.

Window displaying last time used values of time and temperature. If no temperature and time value adjustment within 5seconds, window will display the setting time and temperature.

2. Sleep mode

After set time expires unit remains in stand-by mode for 10 minutes displaying last time used values of time and temperature. After that goes to sleep mode, where only PWR LED is on and display is blanked. Unit wakes-up if any of the buttons is touched.

3. Switch between Celsius and Fahrenheit

In stand-by mode, if you want to switch unit between Celsius and Fahrenheit, press



and held, and then press  together for 10 seconds, until LED beside degrees window changes, lighting up unit required units window(F or C). When temperature is in Celsius, it is 50degree as default. When temperature unit is Fahrenheit, it is 120 degree by default.

4. Light

System power on, press  to turn the light on or off. This output is controlled by AUX button and is not associated with sauna cycle. Light LED indicator is lit, light is on, otherwise, light is off.



5. Time setting

System is in stand-by state, push  and  button to change period of the sauna cycle.



Time can be adjusted between 1 to 60 minutes. Initially for the first 5seconds, when either up or down key is depressed and held, modified value changes every second, if button is pressed continuously for longer than 5 seconds, changes are more rapid, every 0.5 second,

and finally after 15 seconds every 0.25 second, allowing fast wide range changes. During operation time can be only be adjusted down. Meaning operation period will be decreased.◦

6. Temperature setting

System is in stand-by state, push  and  button to change the temperature. Temperature can be adjusted between 1 to 90 degree C (33-190deg F). Initially for the first 5seconds, when either up or down key is depressed and held, modified value changes every second, if button is pressed continuously for longer than 5 seconds, changes are more rapid, every 0.5 second, and finally after 15 seconds every 0.25 second, allowing fast wide range changes. During operation temperature can be only be adjusted down. Meaning operation temperature will be decreased.

7. Sauna

System power on, press  button to turn the sauna heater on, press  again, heater is off. System count down and the time window display the time. When setting time is over, heater shuts off automatically. During sauna operation degrees windows will show target temperature for 1second and current room temperature for 3 seconds. If the current room temperature is lower than the target temperature, heater is on. Heater operation LED indicator is lit and sauna LED indicator is flash every 0.5second. When current room temperature is higher or equal to the target temperature. Heater is off. Sauna operation LED indicator is off and sauna LED indicator is lit. When current room temperature is 4degree C lower than the target temperature, heater works automatically.◦

8. Trouble shooting

Controller is capable of detecting faulty temperature sensor and overheating of the sauna room. Message ts means temperature sensor problem; When current room temperature is more than 110degree C or 230degree F, display window shows too hot, it means overheating of the room. In both conditions heater operation is disabled and sauna becomes not operational until first fault condition is corrected and secondly unit is restarted by power cycling or error is cleared by continuously holding start button for 15 seconds.

Mechanical Controls—Wiring (wall or built-in)

CAUTION: THE MANUAL RESET LIMIT SHALL BE WIRED IN THE CIRCUIT.

Figure 12

European Connection
(L2 = N - "Neutral")

For supply connections, use suitable AWG wires suitable for at least 90°C (190°F). (Use copper wire only).

Ground wire must be insulated.

Mechanical control must be installed outside of the sauna room, into a 3 gang masonry electrical box.

When a magnetic contactor is used, it also must be installed into an appropriate metal electrical enclosure box outside the sauna.

(For control and contactor box sizes refer to page 7 of this manual).

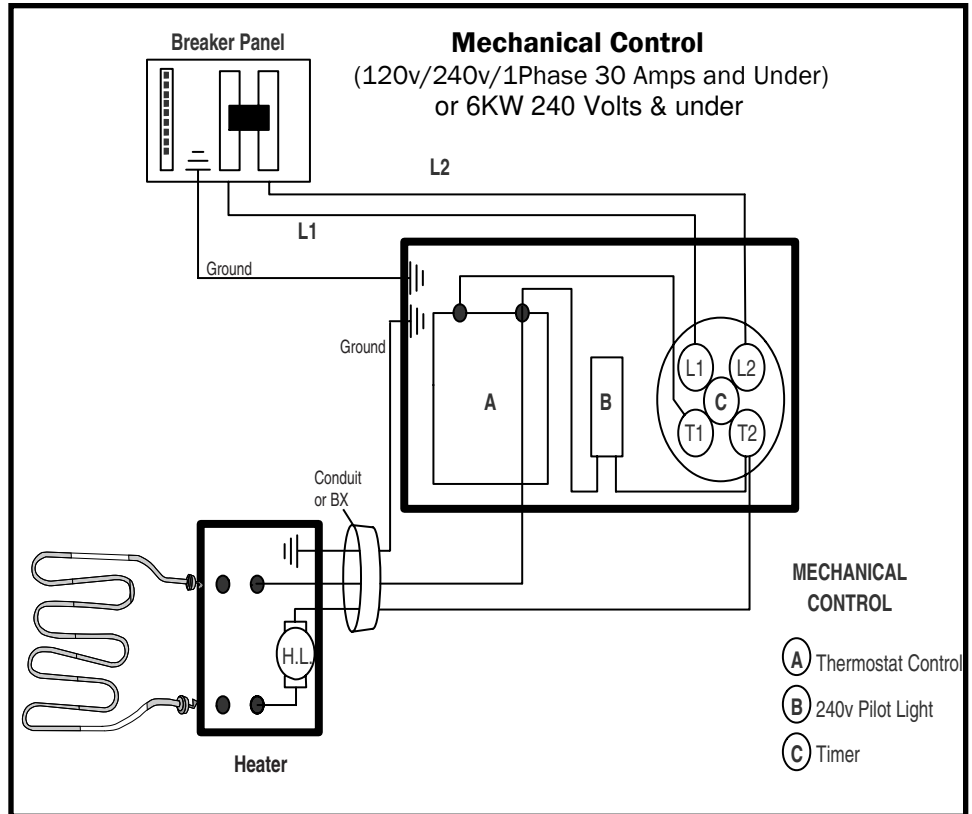
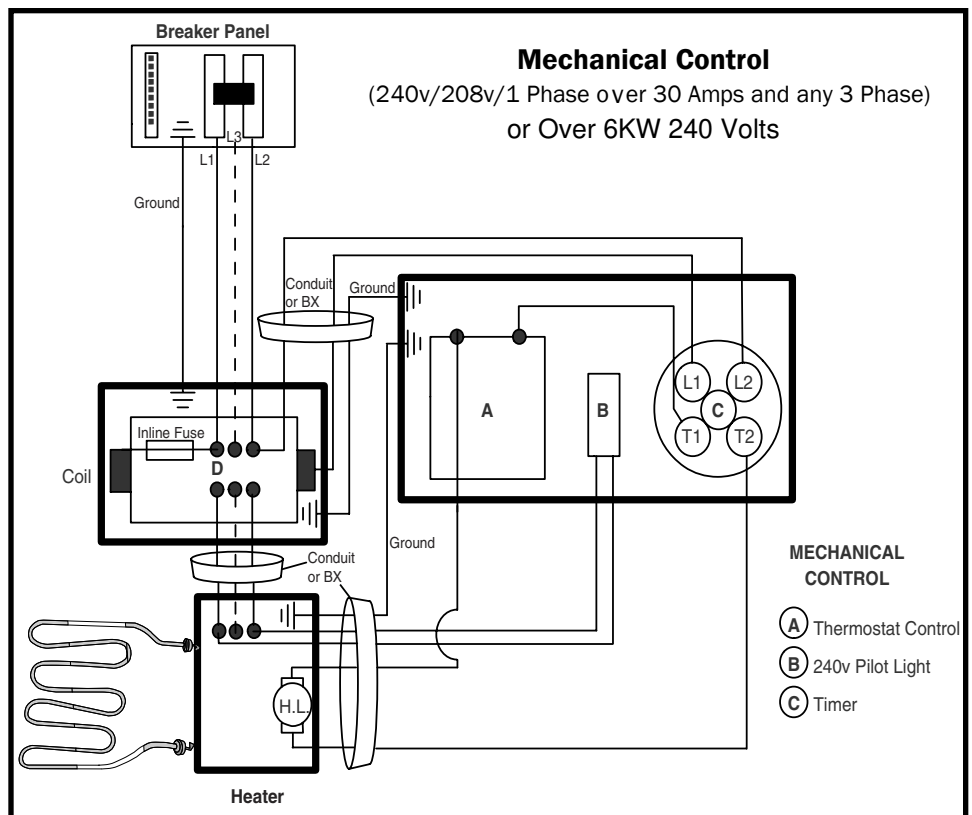

Figure 13

Inline Fuse: 5 amp 240 Volts MAX
(Offers Coil Protection)

Note:
All power supply wires from control box to stove must be protected by metal conduit.

Loose connections or connectors may cause electrical shortage. Make sure all connections and connectors are firmly secure.



Mechanical Controls Built into Sauna Heater

Electrical panel and heater connection diagram.

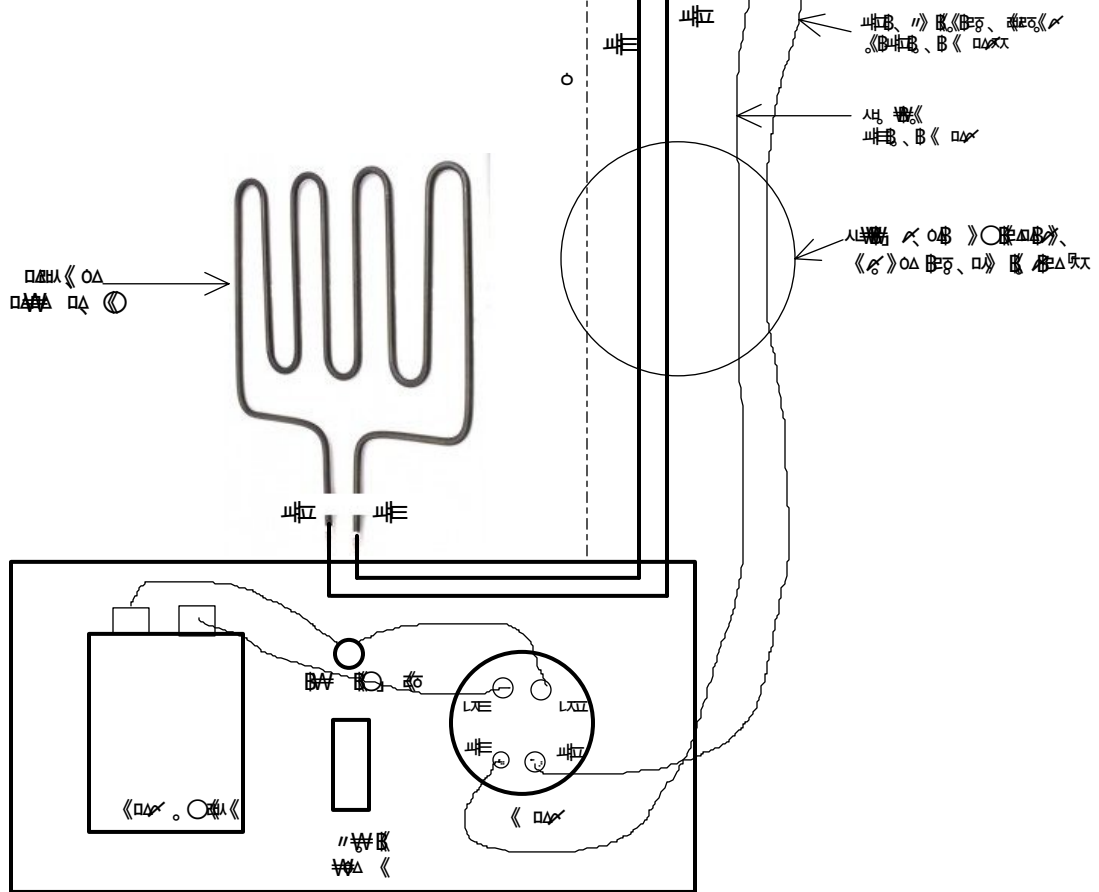
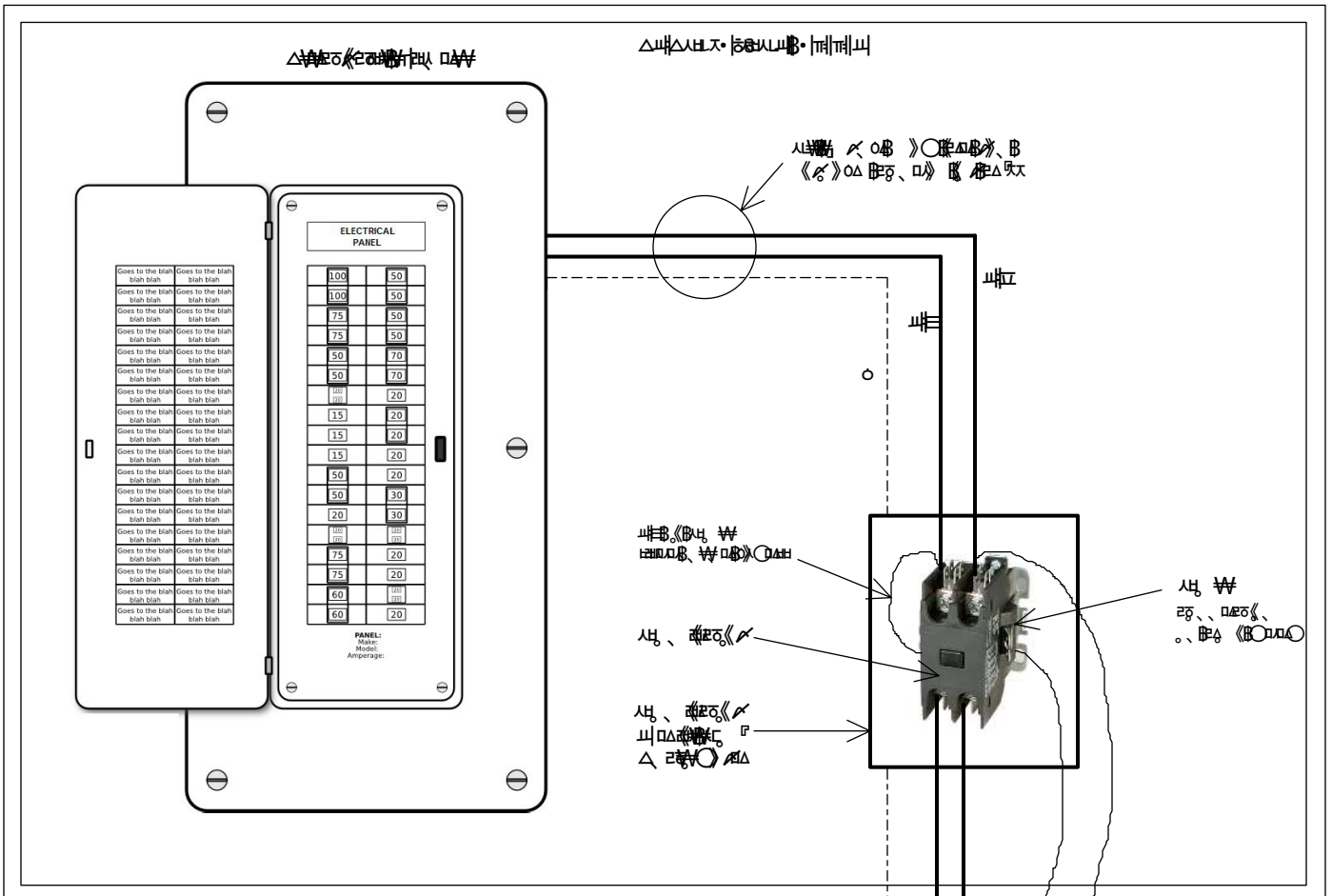

Additional connection information.

Additional connection information.

IMPORTANT: REFER TO PAGE 9 FOR ADDITIONAL INFORMATION.

Mechanical Control

(240v/208v/1 or 3 Phase 50 Amps and over)
(applies to Canadian application)

Figure 14

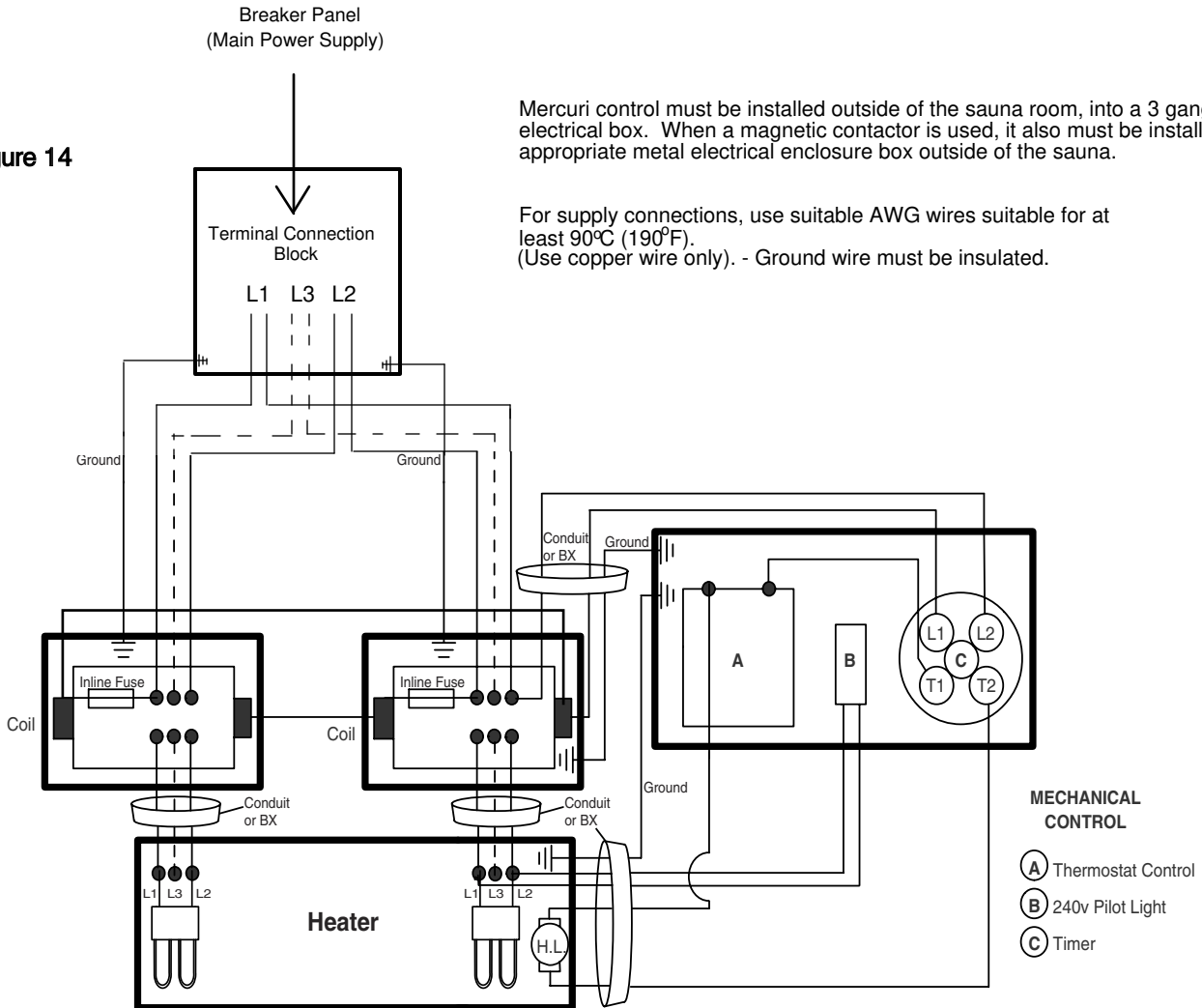

Mercuri control must be installed outside of the sauna room, into a 3 gang masonry electrical box. When a magnetic contactor is used, it also must be installed into an appropriate metal electrical enclosure box outside of the sauna.

For supply connections, use suitable AWG wires suitable for at least 90°C (190°F). (Use copper wire only). - Ground wire must be insulated.

CAUTION: THE MANUAL RESET LIMIT SHALL BE WIRED IN THE CIRCUIT.

Heater Mounting

SAUNACORE

A non-metallic guard rail must be away from the residential sauna heater models by a minimum of 4 inches, and the residential heater models must be minimum 4 inches away from any vertical surface. There must be a minimum of 45 inches clearance above the heater to the ceiling and a minimum of 2 inches above the floor.

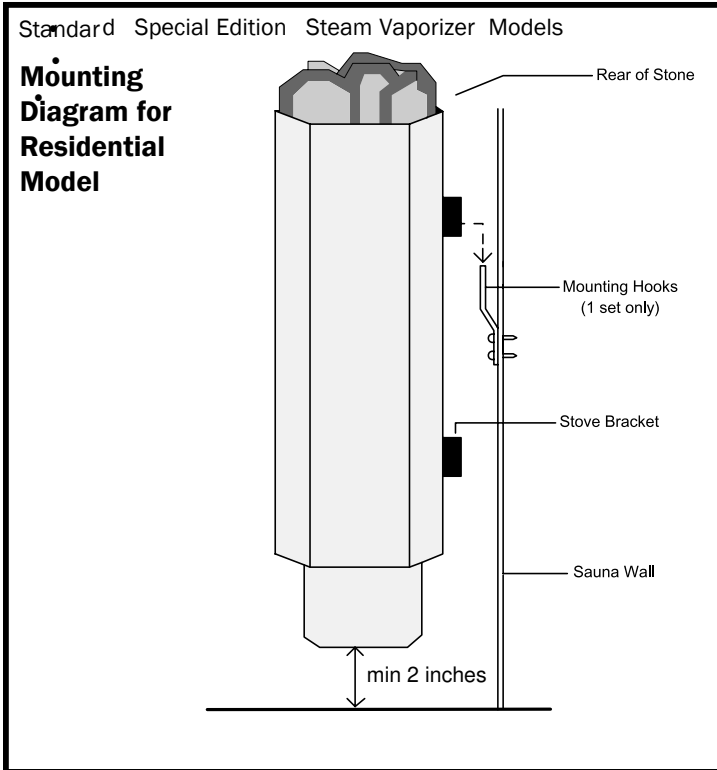

Figure 17

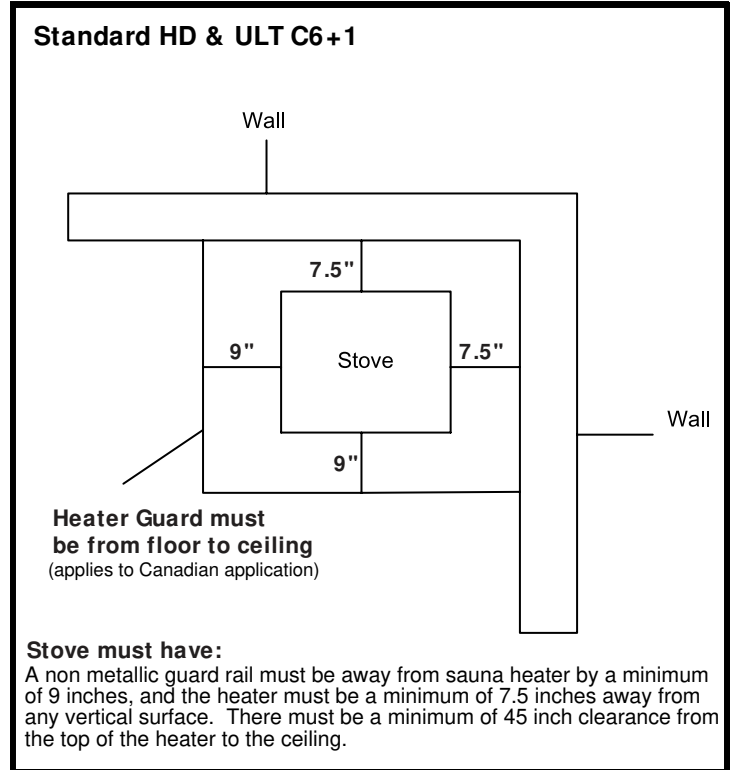

Figure 18

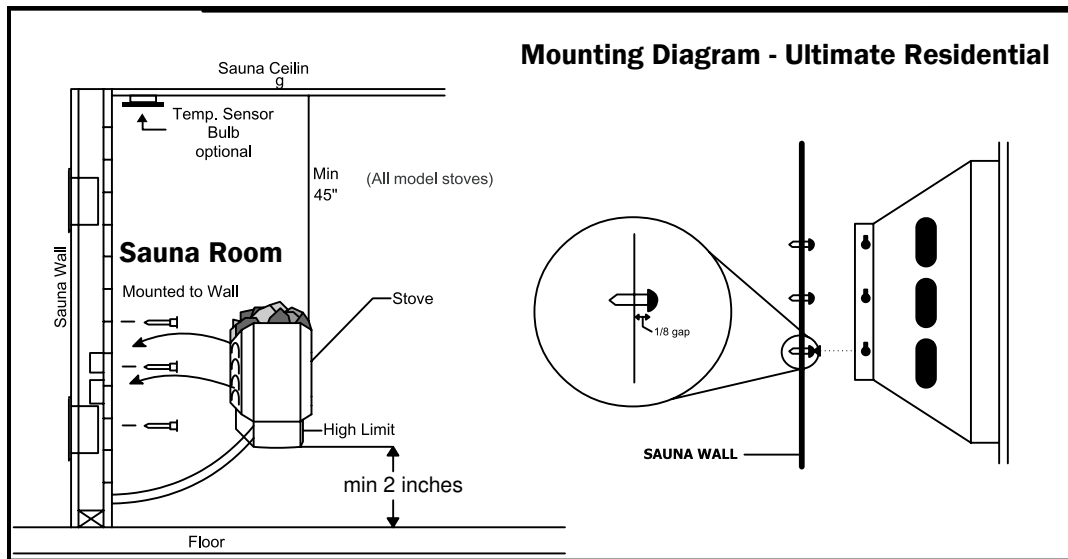

Figure 19

Elite Series

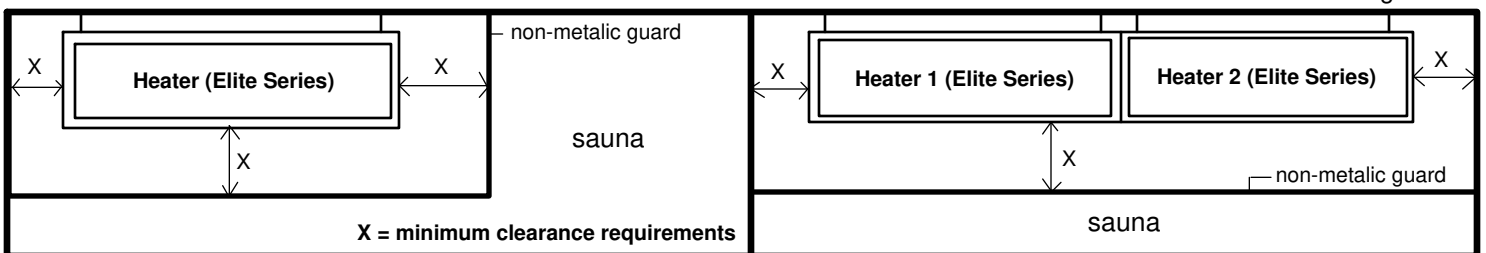

Figure 20

Elite series unit may be mounted side by side to make one complete long unit, but overall clearances stated above must be met for the multi assembled heaters set.

6kw up to 10.5kw (X = 4 inches) - 12kw (X = 9 inches)

Stove must have: A non metallic guard rail must be away from sauna heater 4 inches or 9 inches based on Kilowatt rating of the individual heater. There must be a minimum of 45 inches clearance from the top of the heater to the ceiling.

1. 2. 3. 4. 5. 6. 7. 8. 9. 10. 11. 12. 13. 14. 15. 16. 17. 18. 19. 20. 21. 22. 23. 24. 25. 26. 27. 28. 29. 30. 31. 32. 33. 34. 35. 36. 37. 38. 39. 40. 41. 42. 43. 44. 45. 46. 47. 48. 49. 50. 51. 52. 53. 54. 55. 56. 57. 58. 59. 60. 61. 62. 63. 64. 65. 66. 67. 68. 69. 70. 71. 72. 73. 74. 75. 76. 77. 78. 79. 80. 81. 82. 83. 84. 85. 86. 87. 88. 89. 90. 91. 92. 93. 94. 95. 96. 97. 98. 99. 100.

20 21 22 23 24 25 26 27 28 29 30 31 32 33 34 35 36 37 38 39 40 41 42 43 44 45 46 47 48 49 50 51 52 53 54 55 56 57 58 59 60 61 62 63 64 65 66 67 68 69 70 71 72 73 74 75 76 77 78 79 80 81 82 83 84 85 86 87 88 89 90 91 92 93 94 95 96 97 98 99 100

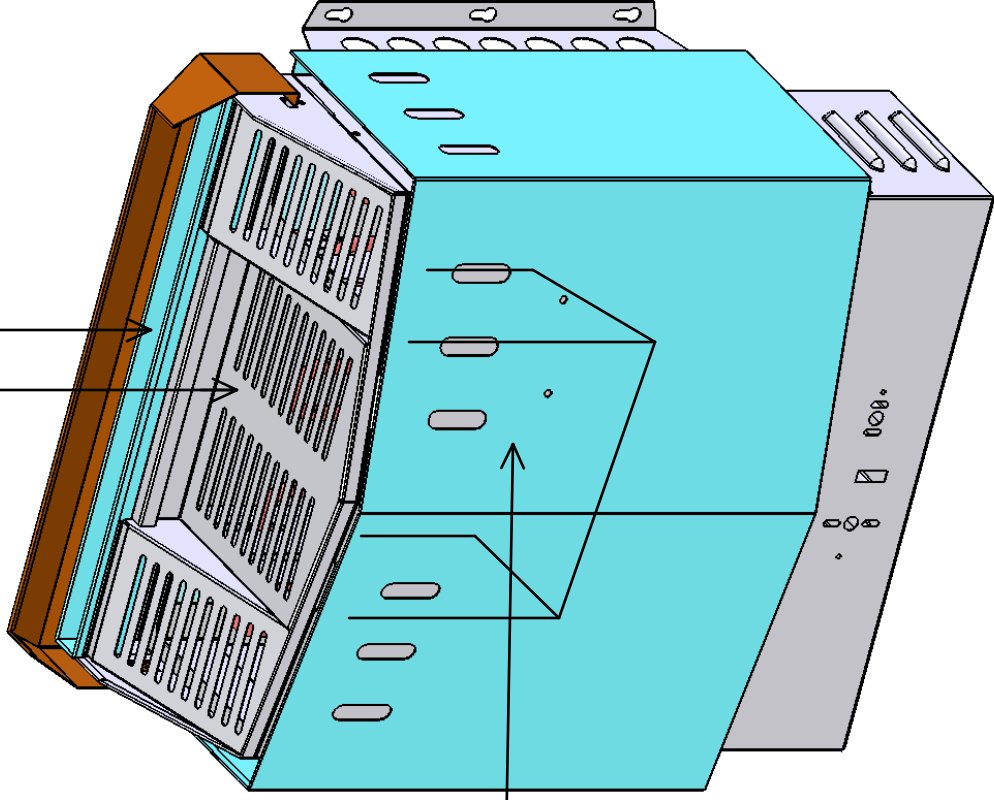

1. 2. 3. 4. 5. 6. 7. 8. 9. 10. 11. 12. 13. 14. 15. 16. 17. 18. 19. 20. 21. 22. 23. 24. 25. 26. 27. 28. 29. 30. 31. 32. 33. 34. 35. 36. 37. 38. 39. 40. 41. 42. 43. 44. 45. 46. 47. 48. 49. 50. 51. 52. 53. 54. 55. 56. 57. 58. 59. 60. 61. 62. 63. 64. 65. 66. 67. 68. 69. 70. 71. 72. 73. 74. 75. 76. 77. 78. 79. 80. 81. 82. 83. 84. 85. 86. 87. 88. 89. 90. 91. 92. 93. 94. 95. 96. 97. 98. 99. 100.

SAUNACORE

Figure 20

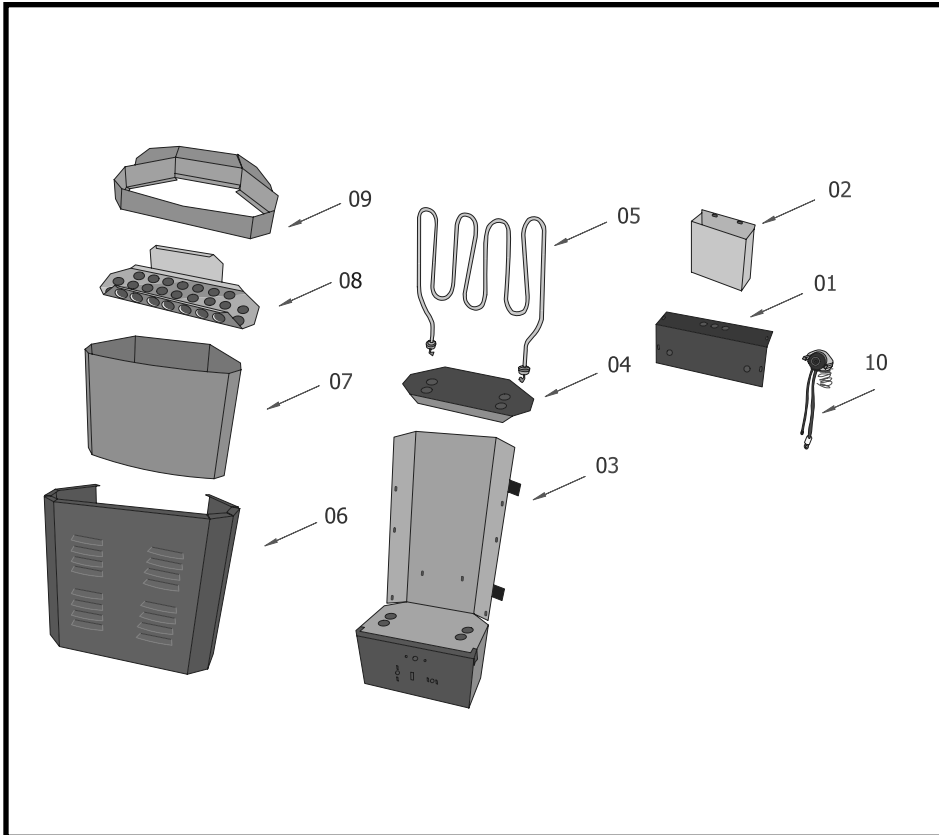

Standard, SE, & SV

- 01- Bottom Connection Box Lid
- 02- S/S Vaporizer Tank
- 03- Rear Body Panel w/conn box
- 04- Lower Heat Shield
- 05- Industrial Heating Element
- 06- FrontBody Panel
- 07- Body Heat Shield
- 08- Rock Grill
- 09- Rock Tray
- 10- High Limit Switch

Figure 21

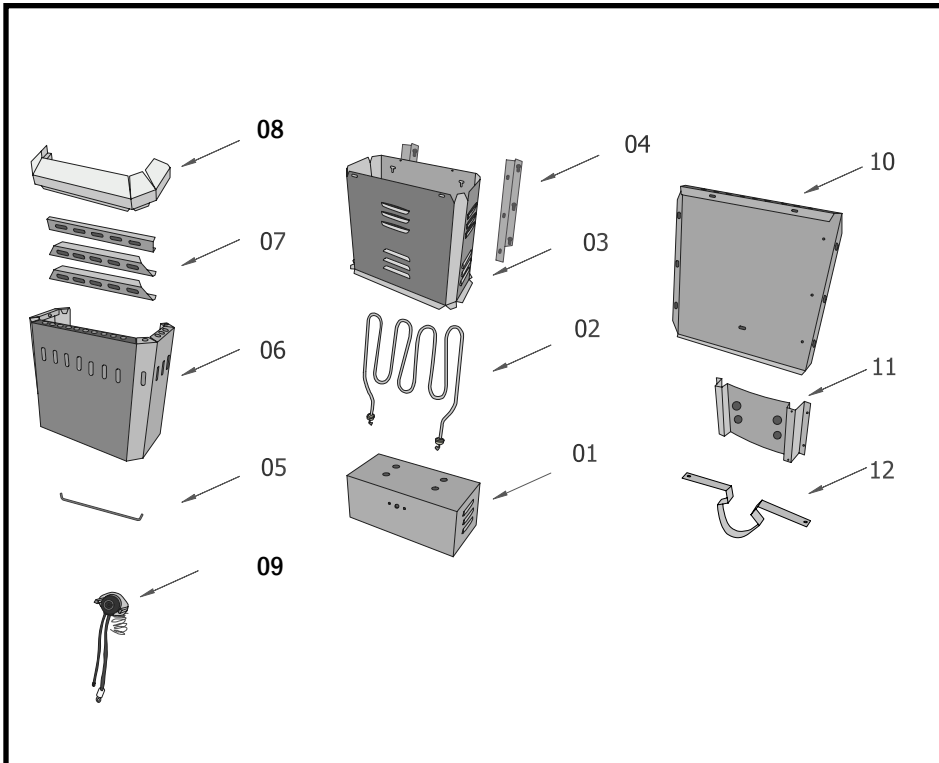

**Ultimate
Sauna Parts**

- 01- Connection Box
- 02- Industrial Heating Element
- 03- Body Heat Shield
- 04- Mounting Body Brackets
- 05- Rock Tray Support Bars
- 06- Front Body Panel
- 07- Rock Grill
- 08- Heat Deflector
- 09- High Limit Switch
- 10- Rear Body Panel
- 11- Lower Heat Shield
- 12- Floor Support Bar (OPT)

Maintenance Instructions

- 1) Saunacore strongly recommends that the sauna floor is made of a material that is easily cleaned. Ceramic tile, concrete, marble, sheet vinyl, etc. are all suitable for use in a sauna. When the sauna floor is made of a non-porous material, it is easy to keep clean, sanitary and odour free. Carpeting is not recommended for use in the sauna.
- 2) To remove perspiration stains from the walls and benches, the wood may be lightly sanded with fine sandpaper to restore its appearance. We do not recommend that stains or sealers be used in the sauna, as they may produce toxic vapours.
- 3) Clean water should always be used in sauna buckets and water should be dumped out after every use. Scour buckets and dippers occasionally when film collects from usage. Use plastic bucket liner in bucket to prevent leakage.
- 4) To maintain appearance of the sauna heater, remove water stains by wiping cool heater with a damp cloth.
- 5) The sauna room will heat faster if the high vent is kept in a closed position during the initial heat up period. The low vent may always be kept in the open position.
- 6) Scrub benches with a soft brush, using soap and water or a mild disinfectant when needed. Typical maintenance in a commercial application is about once a week. Each sauna bather should sit or lie on a towel when taking a sauna, to aid in prolonging the life of the benches.
- 7) A floor drain is recommended for use in commercial applications. It facilitates drainage when a large volume of bathers uses the sauna, as well as easy maintenance.
- 8) Remove duckboard flooring and wash with disinfectant. On wooden duckboards, test disinfectant on a small area to ensure that there is no chemical reaction that may discolour the wood. Hose off duckboard and replace in sauna.
- 9) Required warning signs should always be posted according to the instructions.
- 10) Use only clean water on the sauna stones. Do not use any chemically treated water (such as spa or pool water) on the heater as it will cause rapid oxidation of the internal heater components.
- 11) Saunacore sauna heaters require no special maintenance when properly installed by a qualified electrical contractor. After about 1 year of use, inspect the stones to determine if they need replacement. Rocks may crack or crumble over time.

SAUNACORE

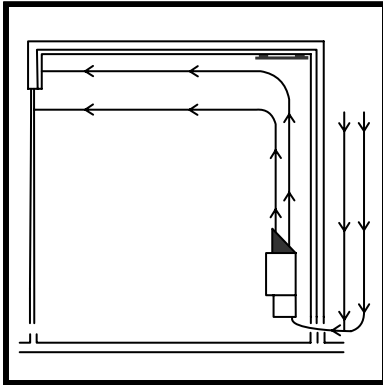

Figure 22 A

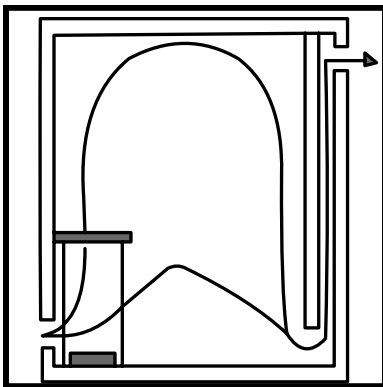

Figure 22 B

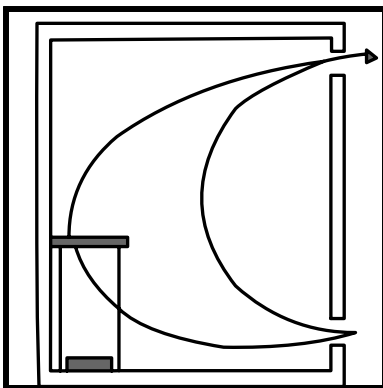

Figure 22 C

Sauna-Use Procedures

1. Sauna must be turned on approximately 15-20 minutes before each initial use in order to heat up sufficiently.
2. Shower before entering the sauna, in order to remove body oils, and dirt. Must remain wet, do not towel off.
3. When entering the sauna, open vent, for maximum oxygen circulation
EXTREMELY IMPORTANT!
4. You may use sauna wet or dry. If wet is desired, pour water onto stones with ladle until desired comfort. May want to use a sauna essence to create a pleasing fragrance during use.
5. May stay in sauna for desired length of time.(max 30 minutes).
6. When completed having a sauna, rinse your body with cool water to close pores and continue bathing.
7. Leave sauna on for approximately 10-20 minutes when finished in order to let the heater and sauna dry out completely.
8. After the sauna is dried out, turn off sauna, and leave louver and door open for release of any existing odours in sauna (ie. body sweat).
9. Eat something light and have a refreshing drink after the sauna. RELAX!!!

CAUTION: Avoid a fire, do not place any combustible material on sauna heater. Reduce the risk of electrocution and burns, DO NOT OPERATE UNLESS THE GUARD IS IN PLACE.

WARNING: REDUCE THE RISK OF OVERHEATING

1. Exit immediately if uncomfortable, dizzy, or sleepy. Staying too long in a heated area is capable of causing overheating.
2. Supervise children at all times.
3. Check with a doctor before use if pregnant, in poor health, or under medical care.
4. Breathing heated air in conjunction with consumption of alcohol, drugs, or medication is capable of causing unconsciousness.

Ventilation

Ventilation in a sauna room is extremely important to achieve the utmost in satisfaction and pleasure. It will also speed up the preheating of the sauna room.

Lack of fresh air due to insufficient ventilation or poor arrangement of ventilation can create an uncomfortable feeling. This often results in the symptoms of difficulty in breathing or burning of the skin. The expended hot air in the sauna contains proportionately less oxygen than the denser atmosphere outside. Bathers sometimes experience faintness unless the air is changed regularly.

An amount of fresh air enters each time the door is opened; this is insufficient, however. Normally two ventilators are built into the walls. The diagram beside shows the proper location of the vent openings. The inlet being located below the heating unit (or close to it) and the outlet is located on the opposite side, on the ceiling or just below the ceiling. Recommended ventilation openings are 4" to 6" diameter, depending on the size of the sauna room.

Heating Units

The heat and moisture content will cause stress to the heating unit in any sauna. Therefore, only the best materials and craftsmanship, as used in our units.

Our heaters have been designed by the means of advanced technology to provide you with years of enjoyment. So for energy efficient and service-free heaters, we feel you have made a good choice with us. Our heaters range from 2000 watts to 21000 watts, and there are 4 physical sizes available: a petite wall mount to a large floor mount.

ALL HEATING UNITS ARE MANUFACTURED TO MEET THE LATEST CSA, UL & CE SAFETY REQUIREMENTS.

How to Enjoy the Best in Saunas... The Finnish Way

Every sauna enthusiast will develop their own style once fully acquainted and confident in the sauna process. There are no fixed rules to follow for enjoying the sauna, as everyone should be free to experiment to get the maximum enjoyment out of their sauna.

This also applies to sauna regulars. There are nights when you just can't take it as hot, as well as days when you wonder how you found all of your extra energy. The sauna can be relaxing or invigorating - depending on you. One should never take more heat than is comfortable and enjoyable and never, never push the limits of endurance.

Before You Start

1. Be prepared to give the sauna plenty of time to do its work - a leisurely sauna is far more beneficial. One to two hours of time is ideal for total relaxation. A number of sessions can be spent in the sauna with short cooling-off and rest periods in between. A longer drying-off and rest period is very relaxing once the sauna is finished.
2. Always wait at least one hour after eating a large meal before using the sauna. Some people find that a sauna first thing in the morning is very invigoration and a great way to start the day. Another ideal time is in the evening - it beats any sedative.
3. Preheat the sauna to a temperature of your liking by setting the thermostat. Most regular sauna users enjoy the heat around 180°F (82°C) although the popular temperature range is from 170° to 190°F (77° to 90°C).
4. Bathers not accustomed to sauna heat should start at a lower temperature around 160°F (70°C) and allow their capacity for enjoying hotter temperatures to develop. Take as much heat as you find comfortable.
5. Wear as little as possible - preferably nothing. A loose towel can be used if necessary. Remove any watches, pendants, jewellery and glasses that would become uncomfortably hot.
6. CAUTION - if you have any form of medical condition or disorder, you should consult your doctor before using the sauna if you are not accustomed to it.

The Sauna Way

7. Many bathers start with a brief warm shower to wash off body oils and dirt.
8. Enter the sauna and relax on the top level for 10 to 15 minutes (or the lower level if you prefer a moderate heat). Many bathers spend about half of their total time lying down. The dry heat will increase the blood circulation and will eventually bring the body to the perspiration point. Otherwise, do not expect to perspire heavily in the dry heat of the first session.

Do not stay longer than 30 minutes - the sauna is not a test of toughness. Any exposure beyond that time can become hazardous as well as beyond all levels of comfort and enjoyment.

Sauna material and wood thickness recommendation:

Materials recommendations for the sauna room should be a long lasting soft wood, such as cedar, red wood, etc.

Western red cedar is an ideal choice for the interior sauna liner for the walls and ceiling. Thickness of panelling 0.25 to 0.75 inches thick.

Cedar is renowned for its high impermeability to liquids and its natural phenol preservative. It is ideally suited for exterior and interior use where humidity is high. Cedar's natural oils are the reason it is decay-resistant and rich in colour.

CAUTION:

Prolonged exposure in the sauna may cause hyperthermia.

Hyperthermia occurs when the internal temperature of the body reaches a level several degrees above the normal body temperature of 98°F. The symptoms of hyperthermia include an increase in the internal temperature of the body, dizziness, lethargy, drowsiness, and fainting. The effects of hyperthermia include failure to perceive heat, failure to recognize the need to exit the sauna, unawareness of impending hazard, fetal damage in pregnant women, physical ability to exit the room and unconsciousness.

Warning: The use of alcohol, drugs, or medication is capable of greatly increasing the risk of fatal hyperthermia.

The sauna door should NOT include any locking or latching system, malfunction of which could cause entrapment inside the heated room. The sauna door should always open outwards from the sauna room.

Hi Limit Reset Tripping (Possible Cause)

Wiring attached to high limit should be adequate gauge.

Excess power supply wire within heater connection box.

Power supply wire or electrical wires must not make any contact within the electrical connection box other than the actual connections.

Inadequate or no sauna room ventilation, an intake & outtake is required (3" diameter per vent hole), gap beneath door is inadequate.

Room insulation must not be greater than R12.

Heater wattage (output) is greater than required. (1000 watts per 50 cubic feet)

Thermostat temperature probe is not located in proper location within the sauna room. Must be located directly above heater up at the ceiling.

Sauna bathers are tampering with thermostat temperature probe, by wetting the thermostat allowing it to read cooler inaccurate room temperature. This will cause the sauna heater to remain on for longer periods, causing internal overheating of the heater.

The hi-limit reset switch can only be reset once the sauna heater has cooled.

Hi-Limit requires replacement by qualified serviceman.

Sauna rocks should be placed loosely within the heater, do not overfill allow heater to breath and allow air to flow through heater body. Do not place rocks below rock tray. Use large diameter rocks.

Heater guard must be set back from heater body according to CSA/UL requirement, listed on label attached to heater body.

The feet should be raised above the head level by using permanent footrests installed on the wall or by placing a portable footrest under the ankles. Portable back and headrests are ideal for greater levels of personal comfort and enjoyment.

9. Shower again or take a cool refreshing swim (hardy types may take an icy dip or a roll in fresh snow). Sudden temperature changes can be bracing and invigorating. Any extreme cold must be followed by sauna heat to avoid catching a chill.
10. Rest for 10 to 15 minutes to allow your body to cool down slowly and then repeat the cycle of heat, shower and rest.
11. When returning to the sauna, throw on several scoops of water with the sauna ladle to create "loily" and to increase the humidity in the room. Bringing the humidity level from a low 5 to 8% to a more comfortable 15% which will allow your skin to remain completely wet with perspiration. You should develop a heat and humidity combination that will bring you the most enjoyment. Some bathers will like it super-dry and some will like it quite humid.
12. The birch whisk or "vihta" can now be used to stimulate the blood circulation on the skin. Whisking the entire body will also induce very heavy perspiration (as a result of the heat and the exertion).
13. Once the body is warm, the pores of the skin will be completely open. This is the time to vigorously scrub the entire body clean. Don't forget to offer to wash your companion's back.
14. Experienced sauna users know that the final cleansing of the skin and pores happens during the heat of the sauna session that follows a vigorous wash.
15. The last shower should be a warm one followed by a cooler shower to close the pores of your skin without chilling the body. Avoid extreme coolness or drafts until the body has returned to normal temperature.
After the Sauna
16. Your body should be allowed to dry without hard toweling. Give yourself at least 20 minutes to relax and cool down before getting dressed. But if you are at home, you will be able to climb right into bed for a very deep and refreshing sleep.
17. A light snack is often served after the sauna with a refreshing cool beverage. The body will need to replace the water and saps that were lost during the sauna.
18. Lighting in and around the sauna should be subdued to develop greater levels of relaxation. Soft background music is also ideal.
19. The sauna is well recommended for those suffering from tension, adolescent skin problems, tiredness or those having trouble sleeping soundly. Arthritis and rheumatism sufferers as well as those with sore muscles and joints from physical over exertion will find the sauna heat very relaxing.

Sauna Heater Limited Warranty

Saunacore warrants these products to be free from defects in material and workmanship and agrees to remedy any such defect. This warranty does not apply outside the boundaries of the United States or Canada, or to any product which in our sole opinion has been improperly installed, or subject to wilful abuse, misuse, alteration, & shipping damages during the period of coverage. Postage and handling charges of the product to and from Saunacore for warranty repairs and for any related charges for the installation/removal of these products are NOT included in your warranty. Warranty service can be obtained by sending your product to Saunacore (Call 905-951-6662). Warranty repairs must be done only by Saunacore. Proof of purchase and a serial number of the product will be required before any services are performed.

This limited warranty is void if the heater is used improperly. Chemically treated water, such as spa or pool water must not be poured over the sauna stones. The sauna room must be heated for a minimum of 30 minutes prior to the application of water to the sauna stones. The limited warranty is void if a shower or faucet has been installed in the sauna. Damages resulting from the misuse of the heater will not be covered in the warranty.

This limited warranty is void if the installation and wiring is not performed by a certified electrician or authorized qualified service representative.

This limited warranty will be void if the information is not completed and returned within 15 days of the date of purchase. The limited warranty applies only to the original purchaser.

A return merchandise authorization number assigned by Saunacore is required prior to returning any product for repair. Components returned without a return authorization number will not be repaired or replaced. Call Saunacore and ask for the service department. Warranty is non-transferable from original consumer purchaser.

Warrants for Each Models: (NOTE: Warranty claim fees apply to individual warranty claim).

Standard Sauna Heater: Residential use has a 5 year warrant first year all parts and labour, 2nd to 5th year a \$150.00 service charge will apply for repairs of the heating unit only, from the date of original purchase. (Thermostat, timer, pilot light, and contactor excluded) Commercial use has only a one year warranty on parts and labour.

Special Edition & Steam Vaporizer Sauna Heater: Residential use has a life-time Warranty; first year all parts and labour, 2nd year and up has an \$200.00 service charge for repairs of the heating unit only, from the date of original purchase. (Thermostat, timer, pilot light, and contactor excluded) Commercial use has only a one year warranty on parts and labour.

STD HD Sauna Heater Residential/Commercial use has a 5 year warranty with steam vaporizer system; first year all parts and labour, 2nd to 5th year a \$300.00 service charge will apply for repairs of the heating unit only, from the original date of purchase. (Thermostat, timer, pilot light, and contactor excluded) Unit without steam vaporizer system has only a one year warranty on parts and labour.

Ultimate C6+1 & Elite : Same warranty as the standard commercial sauna heater but a \$350.00 service charge applies.

Ultimate Sauna Heater: Residential use has a life time warranty; 1st year all parts and labour, 2nd year and up requires a \$200.00 service charge for repairs to the heating unit only, from the original date of purchase. (Thermostat timer, pilot light, and contactor are excluded). Commercial use has only a one year warranty on parts and labour.

Controls: Have a 1 year warranty, except mechanical timers. All mechanical timers have a 60 day warranty.

-Any damage or missing parts claims must be made within 48 hours of receiving this product.

Warranty Registration Card

Model # _____ Serial # _____

Purchase Date _____

Dealer Name and Adress

Owner Name and Address

Current warranty claim fees effective 01/01/2007

NOTE: A COPY OF RECEIPT MUST ACCOMPANY THIS WARRANTY CARD.