



BM-359BNWS CENTURY Single Lever WaterSaver Vessel Faucet

Requested By: _____

Specific Features: _____

STANDARD SPECIFICATIONS:

- Vessel faucet in brushed nickel finish
- Single handle control
- Solid brass construction
- High pressure ceramic cartridge
- Single hole deck mount installation
- 1.5-inch diameter hole required
- Spout reach: 8-inches
- Spout height: 10-inches
- cUPC and AB1953 low lead compliant
- ASME A112.18.1-2011/CSA B125.1-11
- NSF 61 and NSF 372 certified
- WaterSaver - 1.2GPM

WARRANTY:

- Limited lifetime warranty
- See www.Novatto.com for details

COORDINATING ACCESSORIES:

- PUD-BN pop-up drain
- MR-001BN mounting ring
- Glacier Ice Restoration and Sealer kit

NOTES

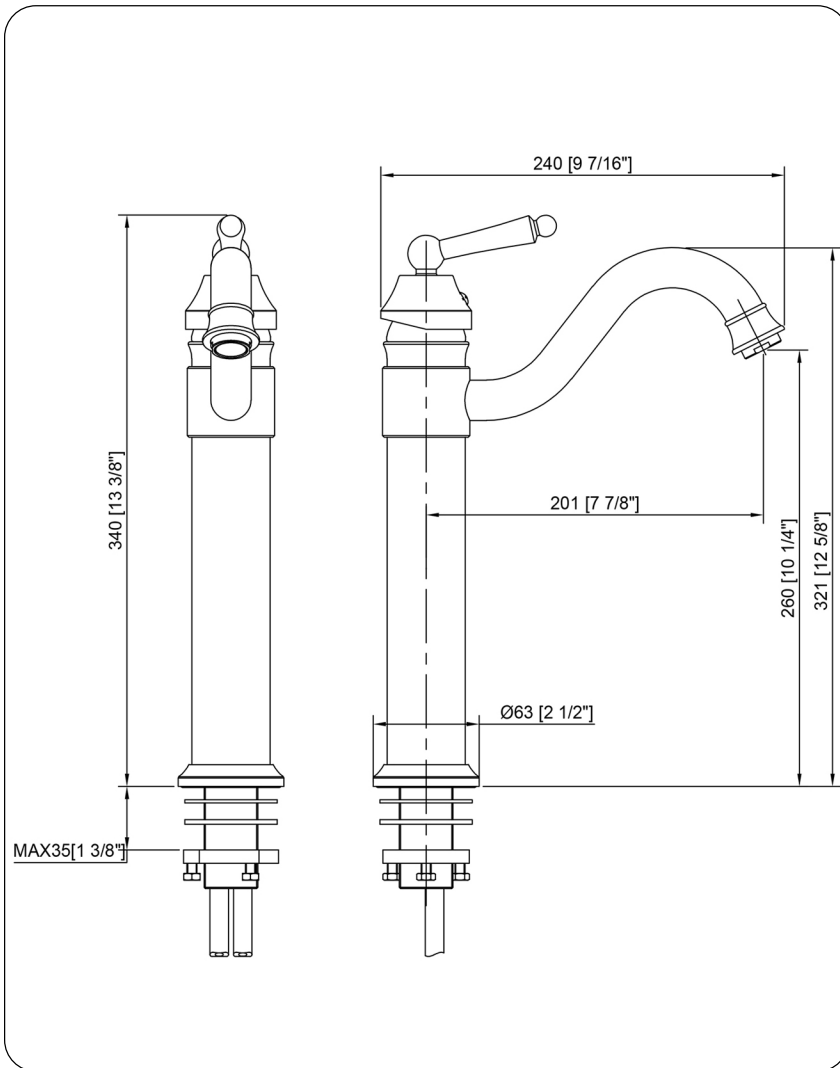
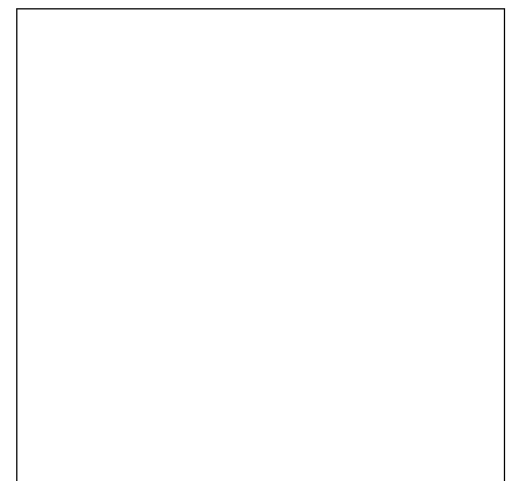

Novatto reserves the right (1) to make changes in specifications and materials, and (2) to change or discontinue models, both without notice or obligation. Dimensions are for reference only, see www.Novatto.com for finish options and product availability.

Novatto Inc
TOLL FREE 844.404.4242
www.Novatto.com



NOVATTO

BM-359ORBWS CENTURY Single Lever Vessel Faucet

Requested By: _____

Specific Features: _____

STANDARD SPECIFICATIONS:

- Vessel faucet in oil rubbed bronze finish
- Single handle control
- Solid brass construction
- High pressure ceramic cartridge
- Single hole deck mount installation
- 1.5-inch diameter hole required
- Spout reach: 6.5-inches
- Spout height: 10-inches
- cUPC and AB1953 low lead compliant
- ASME A112.18.1-1-2011/CSA B125.1-11
- NSF 61 and NSF 372 certified
- EPA WaterSense®

WARRANTY:

- Limited lifetime warranty
- See www.NovattoInc.com for details

COORDINATING ACCESSORIES:

- PUD-ORB pop-up drain
- MR-001ORB mounting ring
- Glacier Ice Restoration and Sealer kit

NOTES

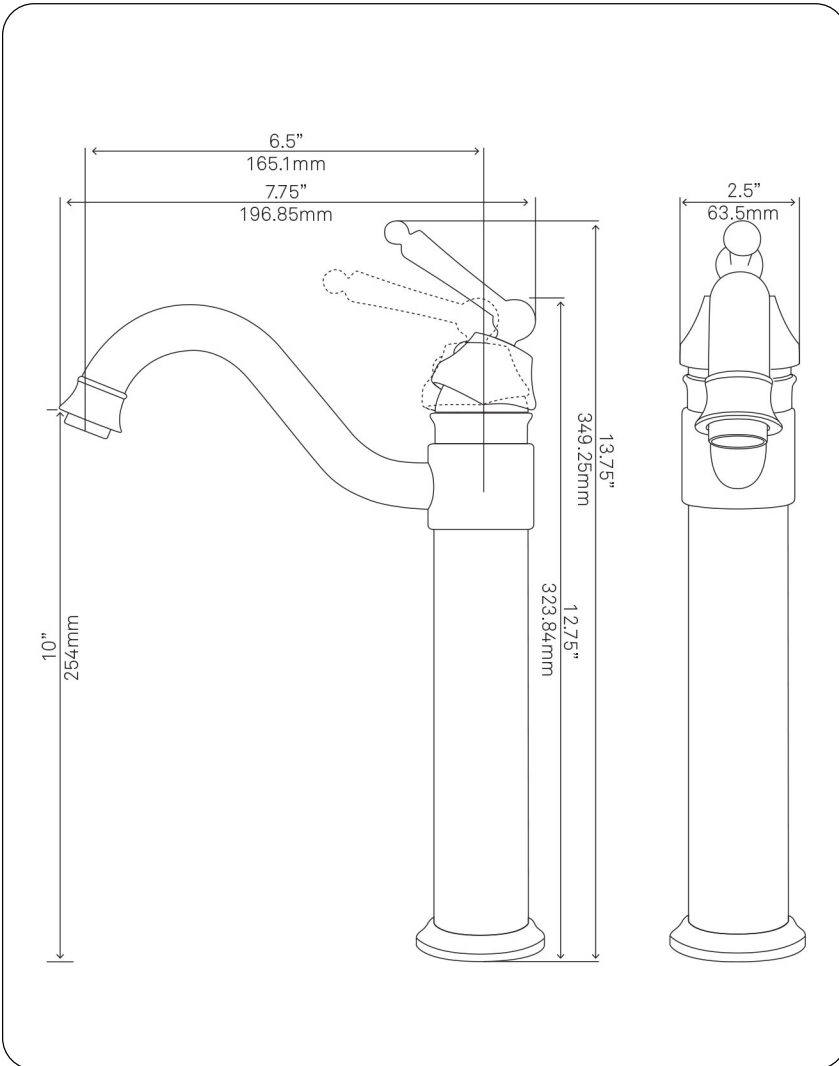

Novatto reserves the right (1) to make changes in specifications and materials, and (2) to change or discontinue models, both without notice or obligation. Dimensions are for reference only, see www.NovattoInc.com for finish options and product availability.

Novatto Inc
TOLL FREE 844.404.4242
www.NovattoInc.com



BM-359SBWS CENTURY Single Lever WaterSaver Vessel Faucet

Requested By: _____

Specific Features: _____

STANDARD SPECIFICATIONS:

- Vessel faucet in satin brass finish
- Single handle control
- Solid brass construction
- High pressure ceramic cartridge
- Single hole deck mount installation
- 1.5-inch diameter hole required
- Spout reach: 8-inches
- Spout height: 10-inches
- cUPC and AB1953 low lead compliant
- ASME A112.18.1-1-2011/CSA B125.1-11
- NSF 61 and NSF 372 certified
- WaterSaver GPM - 1.2

WARRANTY:

- Limited lifetime warranty
- See www.Novatto.com for details

COORDINATING ACCESSORIES:

- PUD-SB pop-up drain
- Glacier Ice Restoration and Sealer kit

NOTES

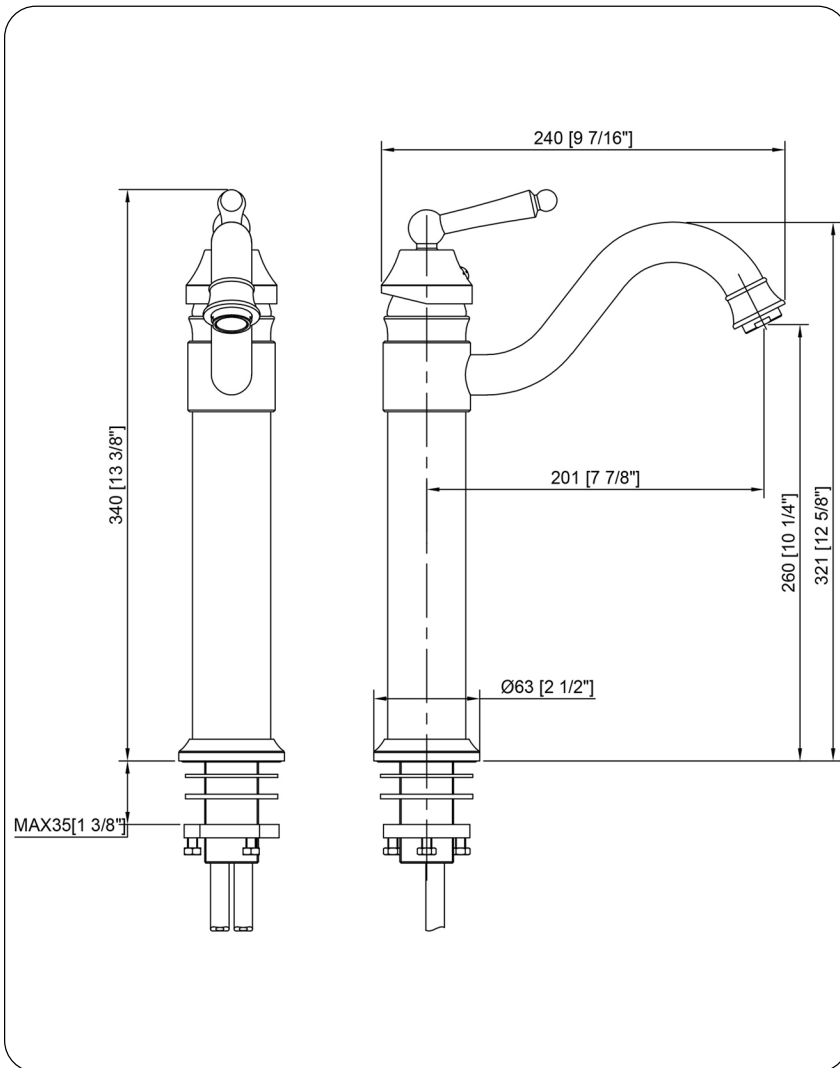
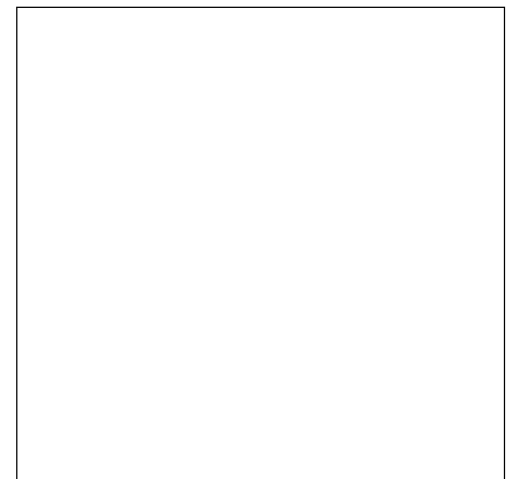

Novatto reserves the right (1) to make changes in specifications and materials, and (2) to change or discontinue models, both without notice or obligation. Dimensions are for reference only, see www.Novatto.com for finish options and product availability.

Novatto Inc
TOLL FREE 844.404.4242
www.Novatto.com