

**McGUIRE  
70" ACRYLIC  
SLIPPER TUB**

Cat. No.  
ATSN70F



L: 69 1/4"  
W: 27 3/4"  
H: 25 3/4" - 33 1/4"

Water depth: 17 1/8" to top of tub

**The following is recommended for ATSN70F tubs:**

- Faucets: part #4602, 7393 or 7410
- Rigid, freestanding supplies: part #4502
- Leg tub drain: part #5599LT

Gallon Capacity : 42  
Shipping Weight: 296 lbs.  
Empty Weight: 96 lbs.  
Filled Weight: 447 lbs.

**Features:**

- ▶ Acrylic construction for lighter weight
- ▶ Gracefully curved design
- ▶ No faucet holes
- ▶ No overflow
- ▶ Tub is thoroughly inspected before shipment

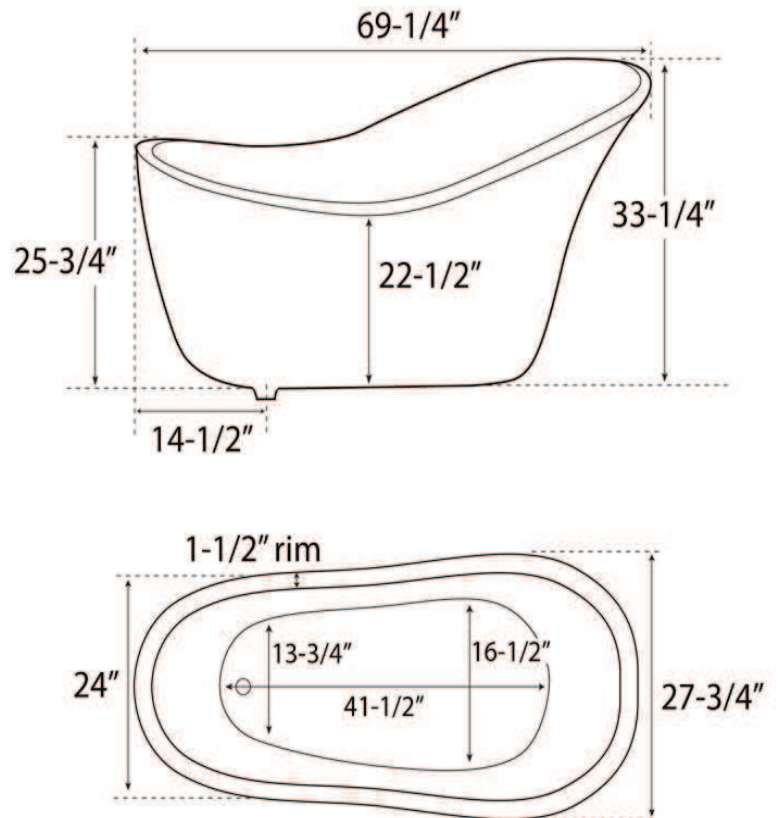

Dimensions of fixture are nominal and specifications subject to change without notice.