

**MELANIE
68" ACRYLIC
SLIPPER TUB**

Cat. No.
ATRSN68F



L: 68"
W: 29 3/4"
H: 22 1/4" - 27 3/4"

Water depth: 17" to top of tub

The following is recommended for ATRSN68F tubs:

- Faucets: part #4602, 7393 or 7410
- Rigid, freestanding supplies: part #4502
- Leg tub drain: part #5599LT

Gallon Capacity: 49
Shipping Weight: 184 lbs.
Empty Weight: 104 lbs.
Filled Weight: 513 lbs.

Features:

- ▶ Interior and exterior walls acrylic sheets
- ▶ Air between sheets provides insulation to help retain warmth
- ▶ Sleek contemporary design
- ▶ No faucet holes
- ▶ No overflow
- ▶ Tub is thoroughly inspected before shipment

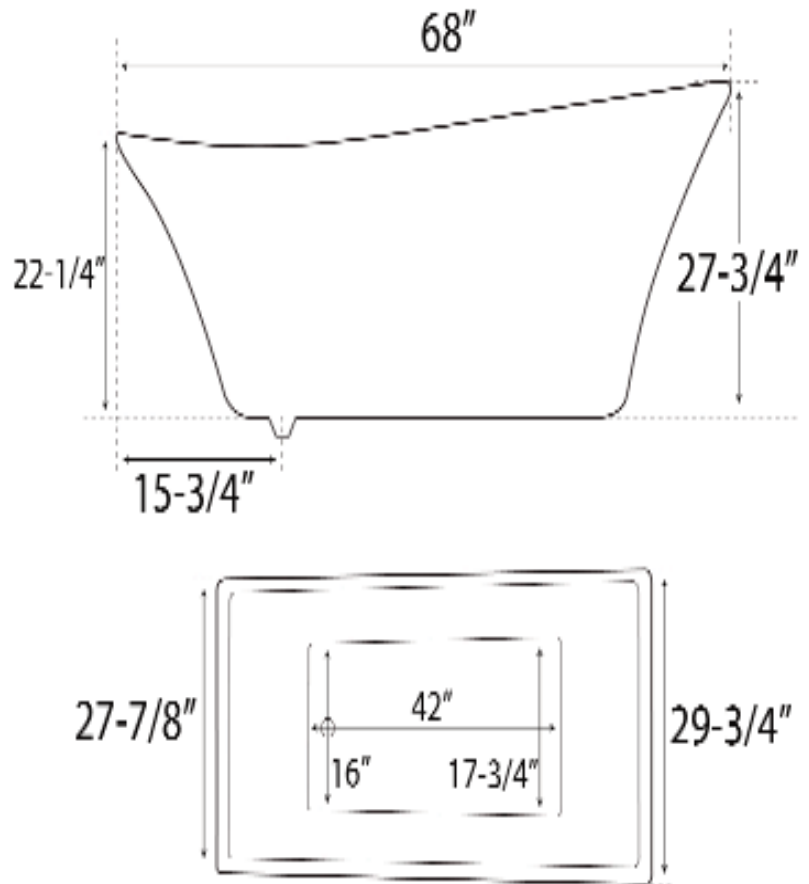

Dimensions of fixture are nominal and specifications subject to change without notice.