

**MARAKESH  
68" ACRYLIC  
SLIPPER TUB**

Cat. No.  
ATRSN68FE



L: 67 3/8"  
W: 29 1/4"  
H: 22 1/2" - 24 3/4"

Water depth: 17 3/8" to top of tub

**The following is recommended for ATRSN68FE tubs:**

- Faucets: part #4602, 7393 or 7410
- Rigid, freestanding supplies: part #4502
- Leg tub drain: part #5599LT

Gallon Capacity: 49  
Shipping Weight: 302 lbs.  
Empty Weight: 102 lbs.  
Filled Weight: 511 lbs.

**Features:**

- ▶ Interior and exterior walls acrylic sheets
- ▶ Air between sheets provides insulation to help retain warmth
- ▶ Sleek contemporary design
- ▶ No faucet holes
- ▶ No overflow
- ▶ Tub is thoroughly inspected before shipment

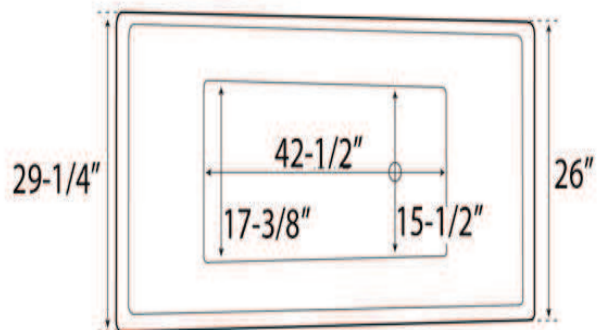
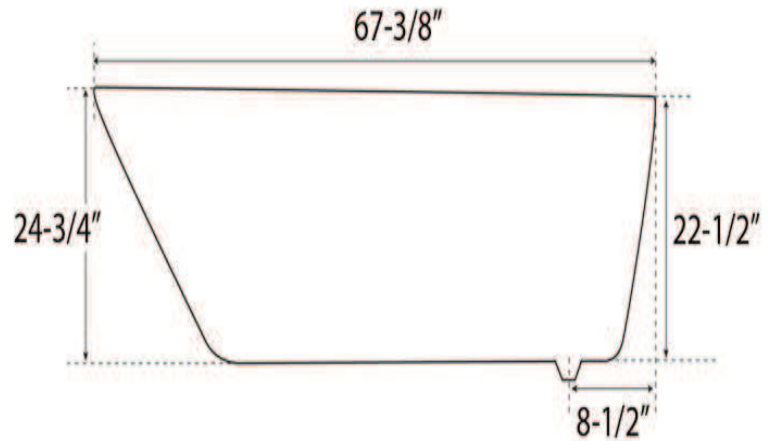

Dimensions of fixture are nominal and specifications subject to change without notice.