

**AMELIA
58" ACRYLIC
ROLL TOP TUB**

Cat. No.
ATRN58



L: 58"
W: 30 1/2"
H: 23"

Water depth: 10 1/2" to overflow

The following is recommended for ATRN tubs:

- Faucets: part #4602, 7393 or 7410
- Rigid, freestanding supplies: part #4502
- Leg tub drain: part #5599

Gallon Capacity : 31
Shipping Weight: 375 lbs.
Empty Weight: 150 lbs.
Filled Weight: 409 lbs.

Features:

- ▶ Acrylic construction for lighter weight
- ▶ Sloped backrest for comfort
- ▶ Ball and claw feet available in 4 finishes
- ▶ No faucet holes
- ▶ Tub feet are attached and leveled before shipment.
- ▶ Tub is thoroughly inspected before shipment

Feet Finishes:

BN Brushed Nickel **PB** Polished Brass
CP Polished Chrome **ORB** Oil Rubbed Bronze

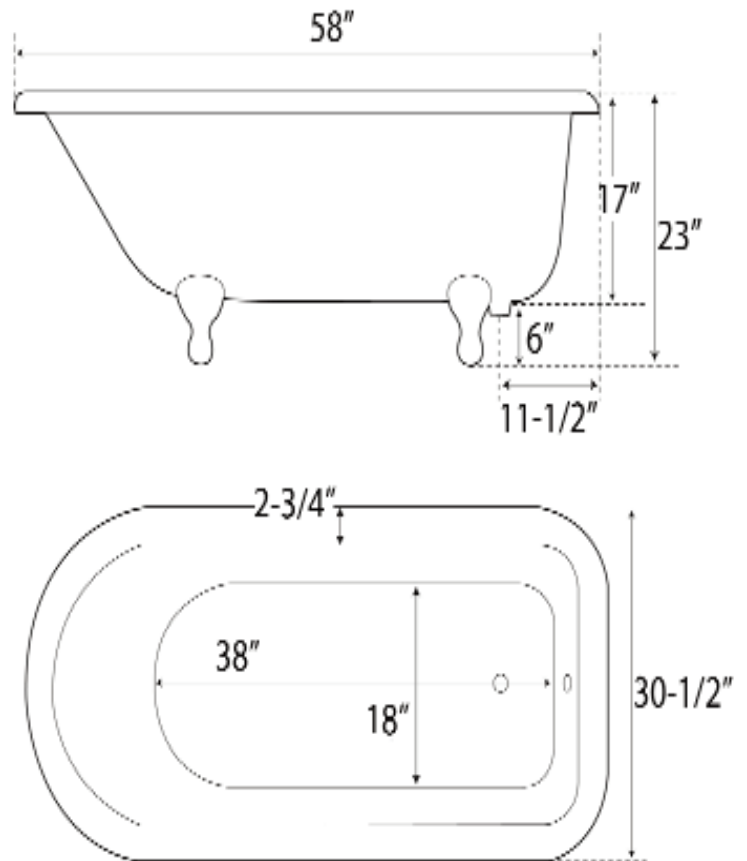

Dimensions of fixture are nominal and specifications subject to change without notice.