

**ALEXIA  
53" ACRYLIC  
ROLL TOP TUB**

Cat. No.  
ATRN53



L: 53"  
W: 31"  
H: 26"

Depth: 19 3/4" at drain  
Water depth: 16 1/4" to overflow  
Overflow hole: 1 1/2"

**The following is recommended for ATRN tubs:**

- Faucets: part #4602, 7393 or 7410
- Rigid, freestanding supplies: part #4502
- Leg tub drain: part #5599

Gallon Capacity: 59  
Shipping Weight: 358 lbs.  
Empty Weight: 178 lbs.  
Filled Weight: 671 lbs.

**Features:**

- ▶ Interior and exterior walls acrylic sheets
- ▶ Space between walls partially filled with fiberglass & resin
- ▶ Solid brass ball and clasp feet available in 6 finishes
- ▶ No faucet holes
- ▶ Tub feet are attached and leveled before shipment.
- ▶ Tub is thoroughly inspected before shipment

**Feet Finishes:**

|                              |                           |
|------------------------------|---------------------------|
| <b>BN</b> Brushed Nickel     | <b>PB</b> Polished Brass  |
| <b>CP</b> Polished Chrome    | <b>WH</b> White           |
| <b>ORB</b> Oil Rubbed Bronze | <b>PN</b> Polished Nickel |

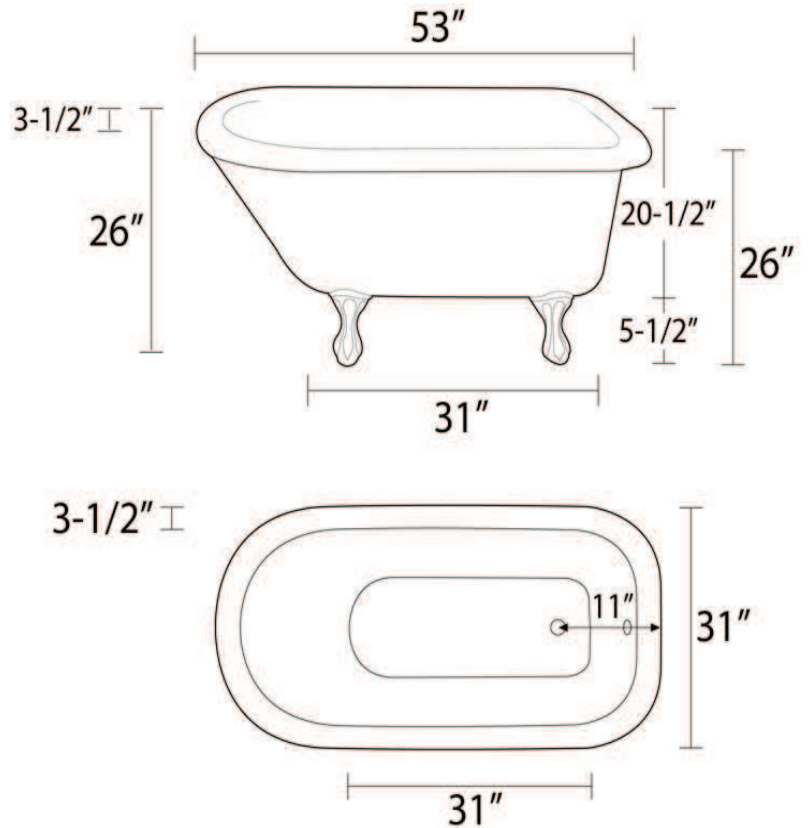

Dimensions of fixture are nominal and specifications subject to change without notice.