

**MONIQUE
69" ACRYLIC DOUBLE
SLIPPER TUB**

Cat. No.
ATDSTD69R



L: 69"
W: 28 1/2"
H: 30 3/4"

Water depth: 17" to top of tub

The following is recommended for ATDSTD69R tubs:

- Faucets: part #4602, 4022 or 4025
- Rigid, freestanding supplies: part #4502
- Leg tub drain: part #5599LT

Gallon Capacity: 53
Shipping Weight: 296 lbs.
Empty Weight: 100 lbs.
Filled Weight: 543 lbs.

Features:

- ▶ Interior and exterior walls acrylic sheets
- ▶ Space between walls partially filled with fiberglass & resin
- ▶ Imperial feet available in 4 finishes
- ▶ For use with freestanding faucet
- ▶ No faucet holes
- ▶ No overflow
- ▶ Tub feet are attached and leveled before shipment.
- ▶ Tub is thoroughly inspected before shipment

Feet Finishes:

BN Brushed Nickel **PB** Polished Brass
CP Polished Chrome **ORB** Oil Rubbed Bronze

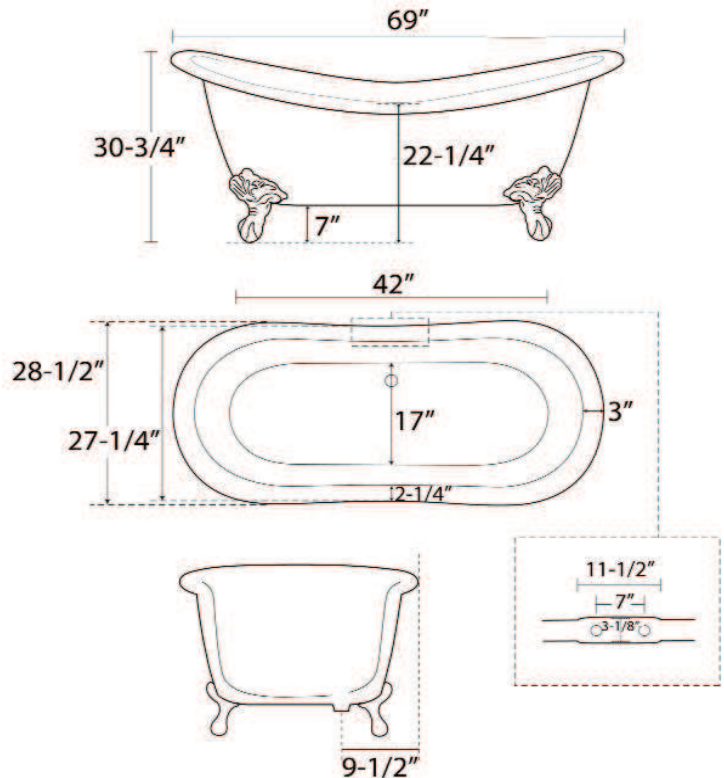

Dimensions of fixture are nominal and specifications subject to change without notice.