

**MONTGOMERY  
ACRYLIC DOUBLE  
SLIPPER TUB**

Cat. No.  
ATDSNTD69B



L: 69"  
W: 28 1/2"  
H: 28 3/8"

Depth: 17" to top of tub

**The following is recommended for ATDSN tubs:**

- Faucets: part #4602, #7393 and #7410
- Use with Freestanding Bath Supplies: part #4502
- Leg tub drain: part #5599LT or #5599TS

Gallon Capacity: 53  
Shipping Weight: 296 lbs.  
Empty Weight: 100 lbs.  
Filled Weight: 543 lbs.

**Features:**

- ▶ Interior and exterior walls acrylic sheets
- ▶ Space between walls partially filled with fiberglass & resin
- ▶ No faucet holes
- ▶ No overflow
- ▶ Tap deck
- ▶ Includes base
- ▶ Tub is thoroughly inspected before shipment

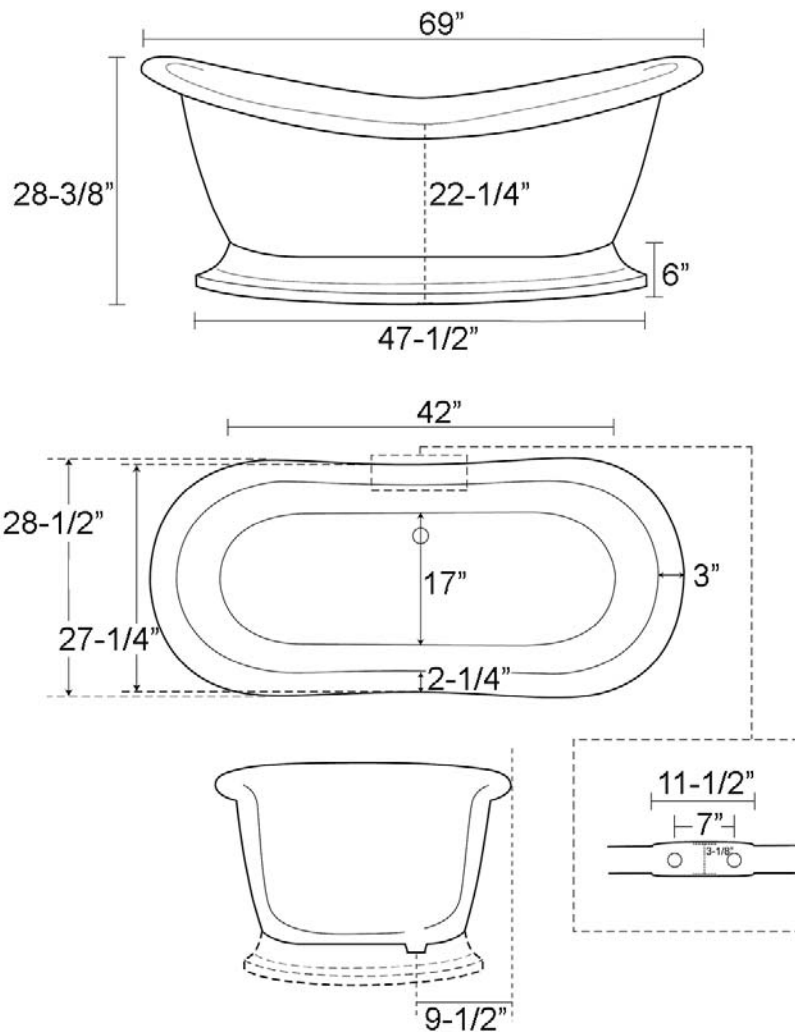

Dimensions of fixture are nominal and specifications subject to change without notice.