

**MONROE
69" ACRYLIC DOUBLE
SLIPPER TUB**

Cat. No.
ADS7H69LP



L: 69"
W: 28 1/2"
H: 30 3/4"

Water depth: 17" to top of tub

The following is recommended for ADS tubs:

- Faucets: part #4602, 7393 or 7410
- Rigid, freestanding supplies: part #4502
- Leg tub drain: part #5599

Gallon Capacity: 53
Shipping Weight: 296 lbs.
Empty Weight: 100 lbs.
Filled Weight: 543 lbs.

Features:

- ▶ Interior and exterior walls acrylic sheets
- ▶ Space between walls partially filled with fiberglass & resin
- ▶ Lion paw feet available in 3 finishes
- ▶ For use with deck mount faucet
- ▶ 7" centers in tub deck
- ▶ Tub feet are attached and leveled before shipment.
- ▶ Tub is thoroughly inspected before shipment

Feet Finishes:

BN Brushed Nickel **PB** Polished Brass
CP Polished Chrome

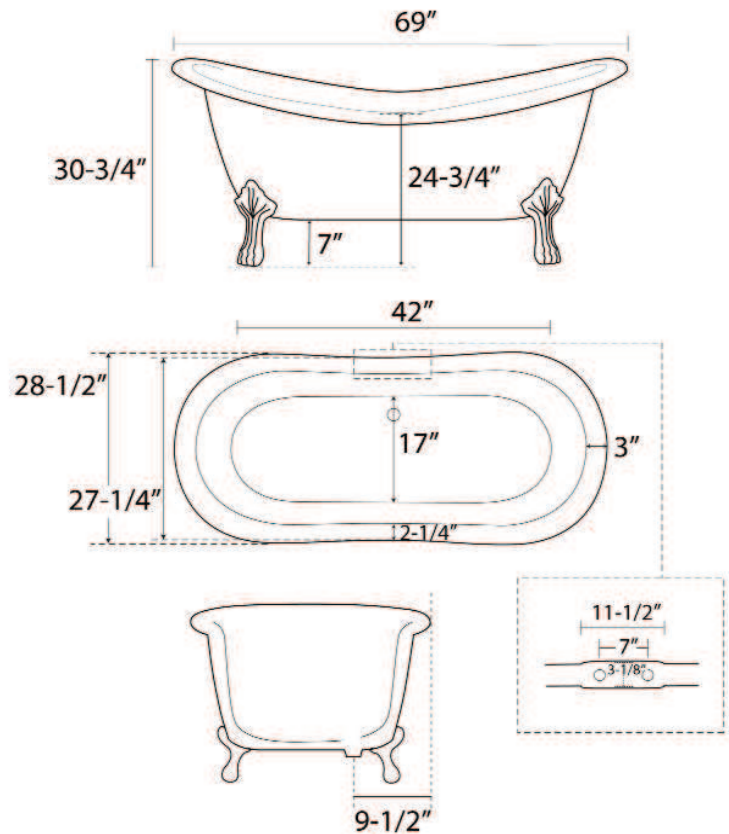

Dimensions of fixture are nominal and specifications subject to change without notice.