

FEATURED MODEL

442071 Equal Double Low Divide, CINDER

ADDITIONAL MODELS

- 442078 Equal Double, Low Divide, CAFE BROWN
- 442077 Equal Double, Low Divide, METALLIC GRAY
- 442075 Equal Double, Low Divide, ANTHRACITE
- 442074 Equal Double, Low Divide, WHITE
- 442076 Equal Double, Low Divide, BISCUIT
- 442073 Equal Double, Low Divide, BISCOTTI
- 442072 Equal Double, Low Divide, TRUFFLE

FEATURES

- Required outside cabinet: 36"
- Low 5-1/2" divide
- 80% solid granite
- Heat resistant up to 536°F
- Unsurpassed cleanability backed by industry leading 7 patents!
- Resistant to scratches, stains and all household acids and alkali solutions
- Template provided with approximate 1/8" reveal
- Undermount clips included
- Limited lifetime warranty

OPTIONAL ACCESSORIES

Sink Grids: 221008 (left), 221009 (right)

CODE/STANDARDS COMPLIANCE

ANSI Z124.6-97
 IAPMO/UPC listed

WARRANTY

BLANCO'S SILGRANIT II Series sinks feature a LIMITED LIFETIME WARRANTY to be free of all manufacturing defects under normal use. See our complete warranty for details.

While BLANCO endeavors to provide accurate information, all dimensions are nominal, cannot be guaranteed, and are subject to change or cancellation. BLANCO assumes no responsibility for use of superseded or voided specifications.

JOB INFORMATION

Job Name: _____

Contact: _____

Date Specified: _____

Specifier: _____

Contractor: _____



Model 442075 shown

NOMINAL DIMENSIONS

OVERALL	CUTOUT SIZE	BOWL DEPTH LEFT	BOWL DEPTH RIGHT	DRAIN DIAMETER
32" x 19-1/4"	Template provided with approximate 1/8" reveal	9-1/2"	9-1/2"	3-1/2"

DXF cutout templates available on our website.

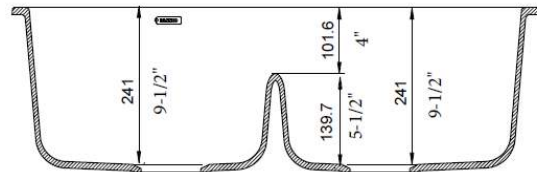
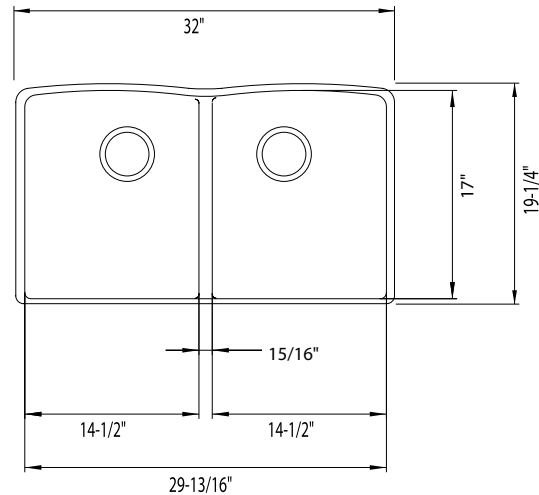

BLANCO AMERICA

800.451.5782

www.blancoamerica.com

© 2015 BLANCO AMERICA

6/15

SPEC-001