

# Installation Instructions / Warranty

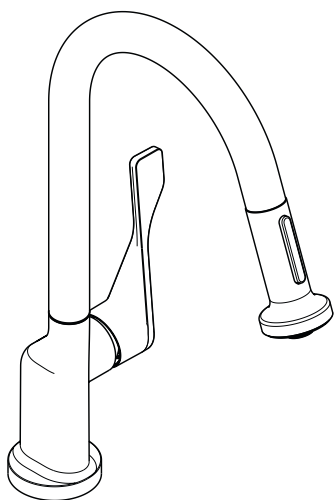

**Axor Citterio**

39835XX1

39836XX1

**AXOR**<sup>®</sup>

**hansgrohe**



## Installation Considerations

- For best results, Hansgrohe recommends that this unit be installed by a licensed, professional plumber.
- Please read over these instructions thoroughly before beginning installation. Make sure that you have all tools and supplies needed to complete the installation.
- Protection against backflow is provided by two check valves in the handspray.
- Keep this booklet and the receipt (or other proof of date and place of purchase) for this product in a safe place. The receipt is required should it be necessary to request warranty parts.

## À prendre en considération pour l'installation

- Pour de meilleurs résultats, Hansgrohe recommande que ce produit soit installé par un plombier professionnel licencié.
- Veuillez lire attentivement ces instructions avant de procéder à l'installation. Assurez-vous de disposer de tous les outils et du matériel nécessaires pour l'installation.
- Deux clapets anti-retour à l'intérieur du gicleur offre une protection contre le siphonnement à retours.
- Conservez ce livret et le reçu (ou une autre preuve sur laquelle figurent la date et l'endroit de l'achat) pour ce produit dans un endroit sûr. Le reçu est requis si vous commandez des pièces sous garantie.

## Consideraciones para la instalación

- Para obtener mejores resultados, la instalación debe estar a cargo de un plomero profesional matriculado.
- Antes de comenzar la instalación, lea estas instrucciones detenidamente. Asegúrese de tener las herramientas y los insumos necesarios para completar la instalación.
- La protección contra flujo inverso se proporciona mediante dos válvulas antirretorno.
- Mantenga este folleto y el recibo (u otro comprobante del lugar y fecha de compra) de este producto en lugar seguro. El recibo se requiere en caso de ser necesario solicitar piezas bajo garantía.

## Installation

Place the faucet and sealing ring on the mounting surface.

Install the plastic washer, friction washer, metal washer, and mounting nut.

If the mounting surface is greater than  $1\frac{3}{8}$ " or if there is insufficient space, omit the plastic washer.

Tighten the mounting nut.

Tighten the screws.

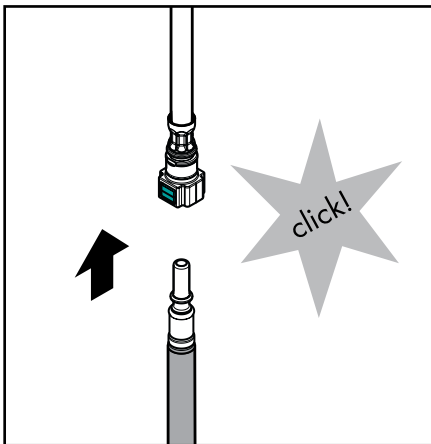
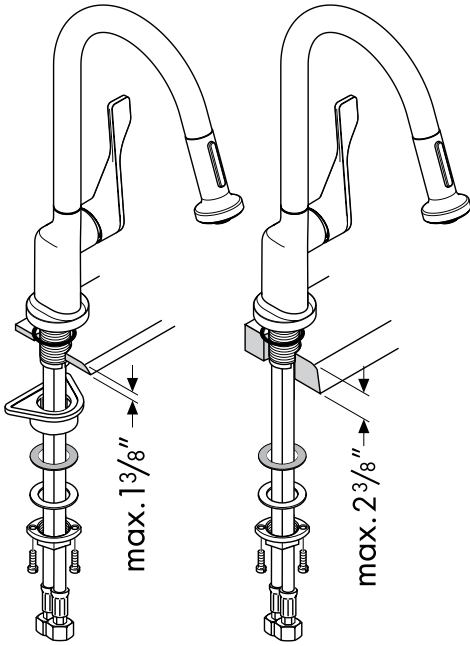

Connect the handspray hose to the connection hose.

## Installation

Placez l'anneau d'étanchéité et le robinet sur la surface de montage.

Installez la rondelle de plastique, la rondelle en fibre, la rondelle de friction, et l'écrou de montage.

Si l'épaisseur du comptoir dépasse 1 $\frac{3}{8}$  po, ou si l'espace disponible est insuffisant, omettez la rondelle de plastique.

Serrez l'écrou de montage et les vis de serrage.

Raccordez le tuyau de la douchette au tuyau d'arrivée de la douchette.

## Instalación

Coloque el oro de sellado y el grifo sobre la superficie de montaje.

Instale la arandela plástica, la arandela de fibra, la arandela de fricción y la tuerca de fijación.

Si el espesor de la mesada es superior a 1 $\frac{3}{8}$  pulg. o si no hay suficiente espacio, puede omitirse la arandela plástica.

Apriete la tuerca de fijación y los tornillos.

Conecte la manguera de rociador de mano a la manguera de suministro.

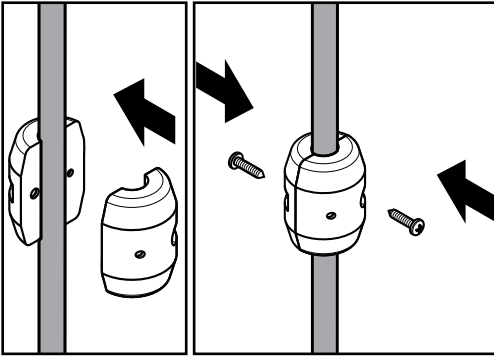

Install the hose weight.

Test the handspray hose. If it does not retract smoothly, reposition the weight.

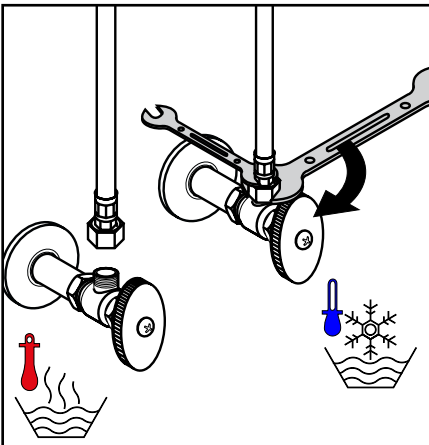
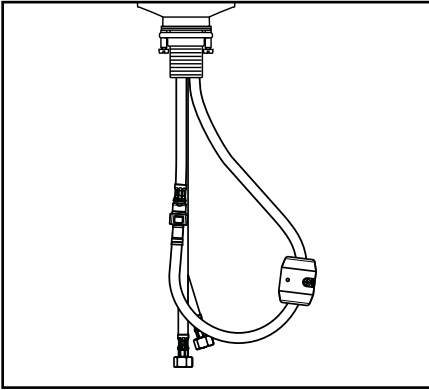

Connect the hot and cold supply hoses to the stops.



**Use two wrenches.**



**Do not allow the supply hoses to twist.**

Installez le contrepoids sur le tuyau.

Tirez sur la douchette. Elle devrait coulisser facilement et se rétracter sans à-coups. Modifiez la position du contrepoids au besoin.

Connectez les tuyaux d'arrivée d'eau chaude et d'eau froide aux tuyau d'alimentation.



**Servez-vous de deux clés, tel qu'illustre dans le schéma. Serrez fermement à l'aide des clés.**



**Assurez-vous que les tuyaux n'sentortillent pas.**

La instalación correcta del contrapeso de la manguera asegura que el rociador de mano se retraiga suavemente.

Tire del rociador de mano. Debe moverse con facilidad y retraerse suavemente. Reposicione el contrapeso según sea necesario.

Conecte las mangueras de suministro de agua caliente y fría a las alimentaciones de la red.



**Use dos llaves, como se ilustra en el diagrama.**



**No permita que ninguna de los mangueras se retuerza.**

## User Instructions / Instructions de service / Manejo

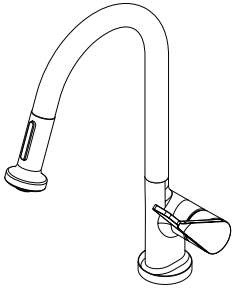

off  
fermé  
cerrar

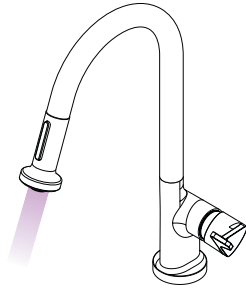

on  
ouvert  
abierto

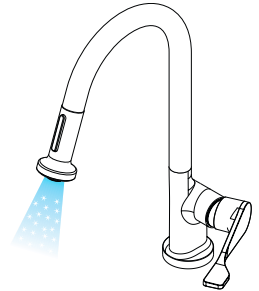
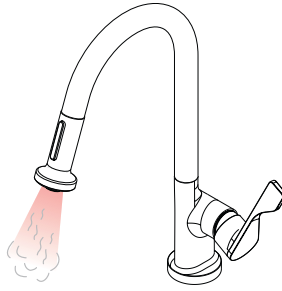

The spout swivels 360°.



**Do not allow the spout to swivel more than 360° or damage to the hose will result.**

Le bec pivote complètement à 360°.



**Ne faites pas pivoter le bec au-delà de 360° vous pourriez endommager le tuyau.**

El surtidor gira 360° como máximo.



**No haga girar el surtidor mas de 360°, puesto que podría dañar la manguera.**

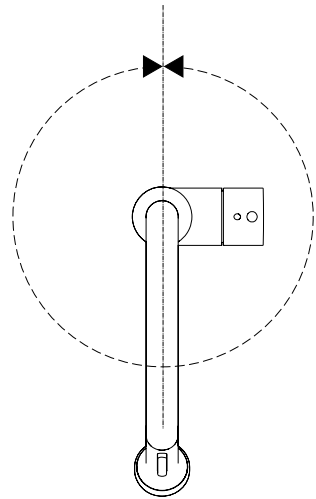

Press the diverter bar to obtain the spray mode.

Release the diverter bar to return to the aerated mode.

Pour activer le mode jet, appuyez sur l'inverseur et retenez-le.

Lorsque vous relâchez l'inverseur, le robinet retourne en mode normale.

Presione y mantenga oprimido el distribuidor para activar el modo de rociado.

Suéltelo para volver al modo de corriente.

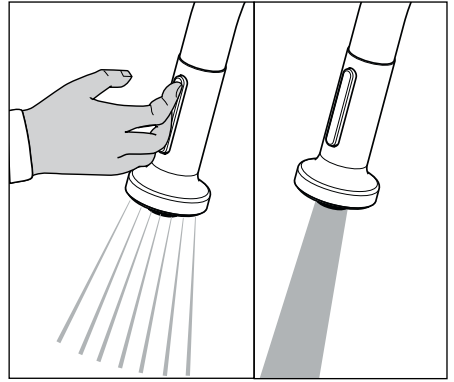

If the flow of water decreases over time, clean the filter.

Si le débit d'eau diminue au fil du temps, retirez le filtre et nettoyez-le.

Si el caudal de agua disminuye con el tiempo, lave el filtro con agua limpia.

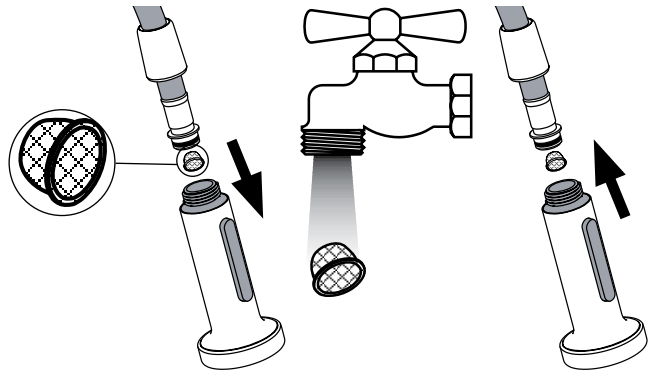

# Replacement Parts / Pièces détachées / Repuestos

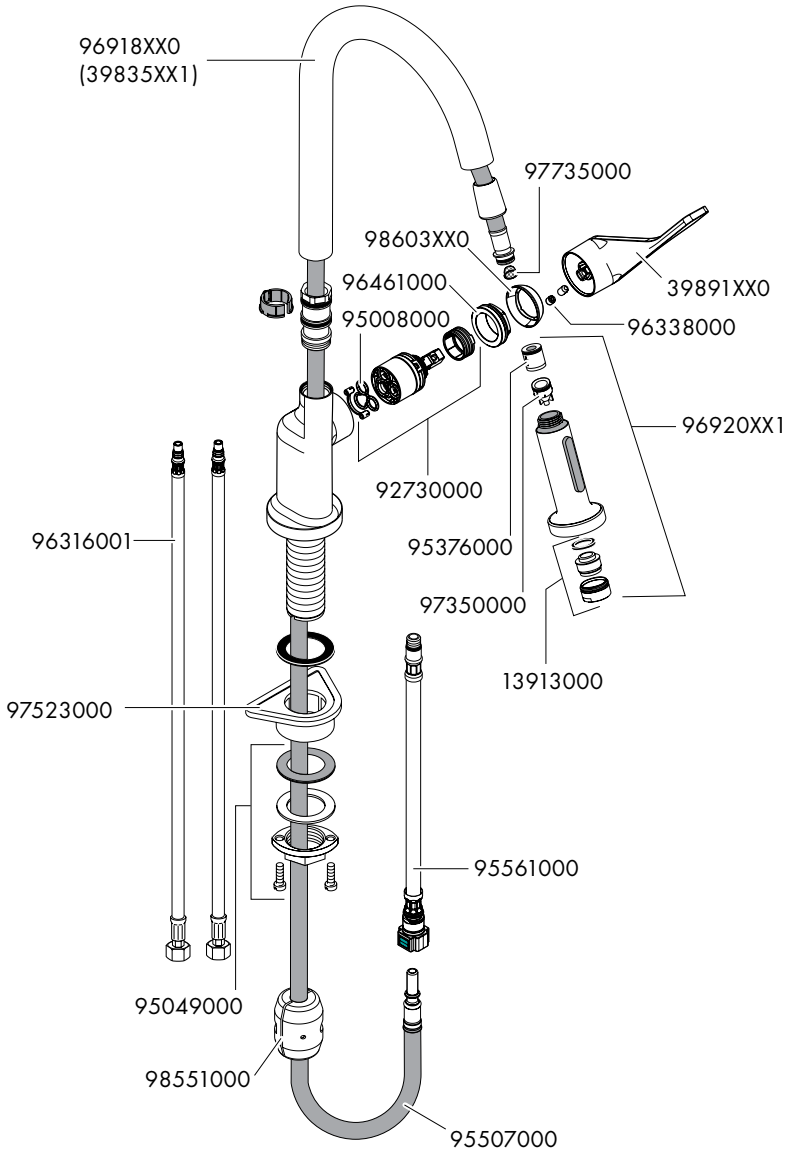

XX = colors / couleurs / acabados

00 = chrome

80 = steel optik

# Cleaning Recommendation for Hansgrohe Products

Modern lavatory faucets, kitchen faucets, and showers consist of very different materials to comply with the needs of the market with regard to design and functionality. To avoid damage and returns, it is necessary to consider certain criteria when cleaning.

## Cleaning Materials for Faucets and Showers

Acids are a necessary ingredient of cleaning materials for removing lime, however please pay attention to the following points when cleaning faucets and showers:

- Only use cleaning materials which are explicitly intended for this type of application.
- Never use cleaning materials which contain hydrochloric, formic, phosphoric, or acetic acid, as they cause considerable damage.
- Never mix one cleaning material with another.
- Never use cleaning materials or appliances with an abrasive effect, such as unsuitable cleaning powders, sponge pads, or micro fiber cloths.

## Cleaning Instructions for Faucets and Showers

Please follow the cleaning material manufacturer's instructions. In addition, pay attention to the following points:

- Clean the faucets and showers as and when required
- Use the amount of cleaning product and the amount of time recommended by the manufacturer. Do not leave the cleaner on the fixture longer than necessary.
- Regular cleaning can prevent calcification.
- When using spray cleaners, spray first onto a soft cloth or sponge. Never spray directly onto the faucet as droplets can enter openings and gaps and cause damage.
- After cleaning, rinse thoroughly with clean water to remove any cleaner residue.

## Important

Residues of liquid soaps, shampoos, and shower foams can also cause damage, so rinse with clean water after using.

**Please note:** if the surface is already damaged, the effect of cleaning materials will cause further damage.

**Components with damaged surfaces must be replaced or injury could result.**

**Damage caused by improper treatment is not covered under the warranty.**

# Recommandations pour le nettoyage des produits Hansgrohe

Les robinetteries modernes de lavabo, de cuisine et de douche utilisent des matériaux très différents pour répondre aux besoins du marché en termes de conception et de fonctionnalité. Certaines règles de base doivent être respectées lors du nettoyage de ces produits afin d'éviter de les endommager ou d'avoir à les retourner.

## Produits de nettoyage pour robinetteries et douches

Les acides sont une partie intégrante nécessaire de tous les produits de détartrage; il faut cependant prendre les précautions suivantes lors du nettoyage des robinets et des douches :

- N'utilisez que des produits/articles de nettoyage conçus spécifiquement pour les articles de robinetterie et de douche.
- N'utilisez jamais de produits/articles de nettoyage contenant de l'acide chlorhydrique, formique, phosphorique ou acétique car ils pourraient causer des dommages considérables.
- Ne mélangez jamais deux produits de nettoyage.
- N'utilisez jamais de produits/articles de nettoyage de nature abrasive tels que poudres de nettoyage, tampons-éponge ou chiffons microfibre non appropriés.

## Instructions de nettoyage pour robinetteries et douches

Veuillez suivre les instructions du fabricant de produits/articles de nettoyage. De plus, tenez compte des conseils suivants :

Nettoyez vos produits de robinetterie et de douche aussi souvent que nécessaire.

- Utilisez la quantité de produit nettoyant et respectez la durée recommandée par le fabricant. Ne laissez pas le produit sur les articles de robinetterie plus longtemps que nécessaire.
- Un nettoyage régulier peut prévenir la formation de dépôts calcaires.
- Si vous utilisez des nettoyeurs en vaporisateur, vaporisez d'abord sur une éponge ou un chiffon. Ne vaporisez jamais directement sur un robinet : des gouttelettes pourraient s'infiltrer dans les ouvertures et les interstices et endommager celui-ci.
- Après le nettoyage, rincez abondamment avec de l'eau propre pour éliminer tout résidu de produit nettoyant.

## Important

Les résidus de savon liquide, de shampoing et de mousse pour la douche peuvent également endommager la robinetterie; rincez donc avec de l'eau propre après utilisation de ces produits.

**Veillez noter :** si la surface est déjà endommagée, les produits de nettoyage l'endommageront encore plus.

**Les composants dont la surface est endommagée devraient être remplacés sous peine d'entraîner des blessures.**

**Les dommages dus à un mauvais traitement ne sont pas couverts par la garantie.**

# Recomendación de limpieza para los productos de Hansgrohe

Hoy en día, las griferías de baño y de cocina así como duchas modernas se componen de materiales muy distintos para satisfacer las exigencias del mercado respecto al diseño y la funcionalidad. Para evitar daños reclamaciones hay que tener en cuenta ciertos aspectos tanto en el uso como en su limpieza posterior.

## **Para elucido de las griferías y las duchas en principio hay que seguir lo siguiente:**

- Usar sólo detergentes previstos específicamente para este campo de aplicación.
- No aplicar detergentes que contengan hipoclorito sódico, ácido clorhídrico, fórmico o acético porque pueden causar daños importantes.
- Detergentes que contienen ácido fosfórico tampoco pueden ser aplicados ilimitadamente.
- Por regla general no se deben mezclar detergentes.
- Tampoco se deben utilizar utensilios abrasivos, como son polvos abrasivos, esponjas o paños de microfibra.
- Si tienen que seguir siempre las instrucciones de uso de los fabricantes de los detergentes.
- La limpieza tiene que ser realizada según la dosificación y el tiempo de actuación, en función del objeto y ajustada a las necesidades específicas del mismo.
- Gracias a una limpieza periódica se pueden evitar las incrustaciones de cal.
- No conviene rociar el detergente en ningún caso sobre la grifería sino sobre los textiles y ejecutar la limpieza así porque el líquido puede entrar en aperturas o hendiduras de la grifería y causar daños.
- Después de la limpieza hay que aclarar con suficiente agua para eliminar completamente el resto de detergente.
- La utilización de limpiadores a vapor no está permitida, las altas temperaturas pueden dañar los productos.

## **Indicaciones importantes**

Los residuos de productos de aseo como jabón líquido, champús y gel de ducha pueden dañar también los materiales.

Por lo que también se deberá prestar atención a lo siguiente: aclarar con abundante agua después del uso.

Con materiales ya dañados la acción de detergentes incrementará el desgaste de estos.

**Los componentes con superficies dañadas deberán cambiarse, en otro caso se corre el peligro de lesionarse.**

**Los daños que resulten de un uso inadecuado no están incluidos en nuestra garantía.**

# Limited Lifetime Consumer Warranty

This product has been manufactured and tested to the highest quality standards by Hansgrohe, Inc. ("Hansgrohe"). This warranty is limited to Hansgrohe products which are purchased by a consumer in the United States after March 1, 1996, and installed in either the United States or Canada.

## WHO IS COVERED BY THE WARRANTY

This warranty extends to the original consumer purchaser only. This warranty is non-transferable.

## WHAT IS COVERED BY THE WARRANTY

This warranty covers only your Hansgrohe manufactured product. Hansgrohe warrants this product against defects in material or workmanship as follows: Hansgrohe will repair at no charge for parts only or, at its option, replace any product or part of the product that proves defective because of improper workmanship and/or material, under normal installation, use, service and maintenance. If Hansgrohe is unable to provide a replacement and repair is not practical or cannot be timely made, Hansgrohe may elect to refund the purchase price in exchange for the return of the product.

## LENGTH OF WARRANTY

Replacement or repaired parts of products will be covered for the term of this warranty as stated in the following two sentences. If you are a consumer who purchased the product for use primarily for personal, family, or household purposes, this warranty extends for as long as you own the product and the home in which the product is originally installed. If you purchased the product for use primarily for any other purpose, including, without limitation, a commercial purpose, this warranty extends only (i) for 1 year, with respect to Hansgrohe and Commercial products, and (ii) for 5 years, with respect to AXOR products.

## THIS WARRANTY DOES NOT COVER, AND HANSGROHE WILL NOT PAY FOR:

- A. Conditions, malfunctions or damage not resulting from defects in material or workmanship.
- B. Conditions, malfunctions or damage resulting from (1) normal wear and tear, improper installation, improper maintenance, misuse, abuse, negligence, accident or alteration, or (2) the use of abrasive or caustic cleaning agents or "no-rinse" cleaning products, or the use of the product in any manner contrary to the product instructions. (3) Conditions in the home such as excessive water pressure or corrosion.
- C. Labor or other expenses for the disconnection, deinstallation, or return of the product for warranty service, or for installation or reinstallation of the product (including but not limited to proper packaging and shipping costs), or for installation or reinstallation of the product.
- D. Accessories, connected materials and products, or related products not manufactured by Hansgrohe.

## TO OBTAIN WARRANTY PARTS OR INFORMATION

Contact your Hansgrohe retailer, or contact Technical Service at:

Hansgrohe Inc.  
1492 Bluegrass Lakes Parkway  
Alpharetta GA 30004  
Toll-free (800) 334-0455.

In requesting warranty service, you will need to provide

1. The sales receipt or other evidence of the date and place of purchase.
2. A description of the problem.
3. Delivery of the product or the defective part, postage prepaid and carefully packed and insured, to Hansgrohe Inc. 1492 Bluegrass Lakes Parkway, Alpharetta, Georgia 30004, Attention: Technical Service, if required by Hansgrohe.

When warranty service is completed, any repaired or replacement product or part will be returned to you postage prepaid.

## EXCLUSIONS AND LIMITATIONS

REPAIR OR REPLACEMENT (OR, IN LIMITED CIRCUMSTANCES, REFUND OF THE PURCHASE PRICE) AS PROVIDED UNDER THIS WARRANTY IS THE EXCLUSIVE REMEDY OF THE PURCHASER. HANSGROHE NEITHER ASSUMES NOR AUTHORIZES ANY PERSON TO CREATE FOR IT ANY OBLIGATION OR LIABILITY IN CONNECTION WITH THIS PRODUCT.

HANSGROHE SHALL NOT BE LIABLE TO PURCHASER OR ANY PERSON FOR ANY INCIDENTAL, SPECIAL, OR CONSEQUENTIAL DAMAGES, ARISING OUT OF BREACH OF THIS WARRANTY OR ANY IMPLIED WARRANTY (INCLUDING MERCHANTABILITY).

Some States do not allow the exclusion or limitation of incidental or consequential damages, so the above limitation or exclusion may not apply to you. This warranty gives you specific legal rights, and you may have other rights which vary from State to State. You may be required by law to give us a reasonable opportunity to correct or cure any failure to comply before you can bring any action in court against us under the Magnuson-Moss Warranty Act.

#### PRODUCT INSTRUCTIONS AND QUESTIONS

Upon purchase or prior to installation, please carefully inspect your Hansgrohe product for any damage or visible defect. Prior to installing, always carefully study the enclosed instructions on the proper installation and the care and maintenance of the product. If you have questions at any time about the use, installation, or performance of your Hansgrohe product, or this warranty, please call or write to us or call us toll-free at 800 334 0455.

**hansgrohe**

Hansgrohe, Inc. • 1490 Bluegrass Lakes Parkway • Alpharetta, GA 30004  
Tel. 770-360-9880 • Fax 770-360-9887

**[www.hansgrohe-usa.com](http://www.hansgrohe-usa.com)**