

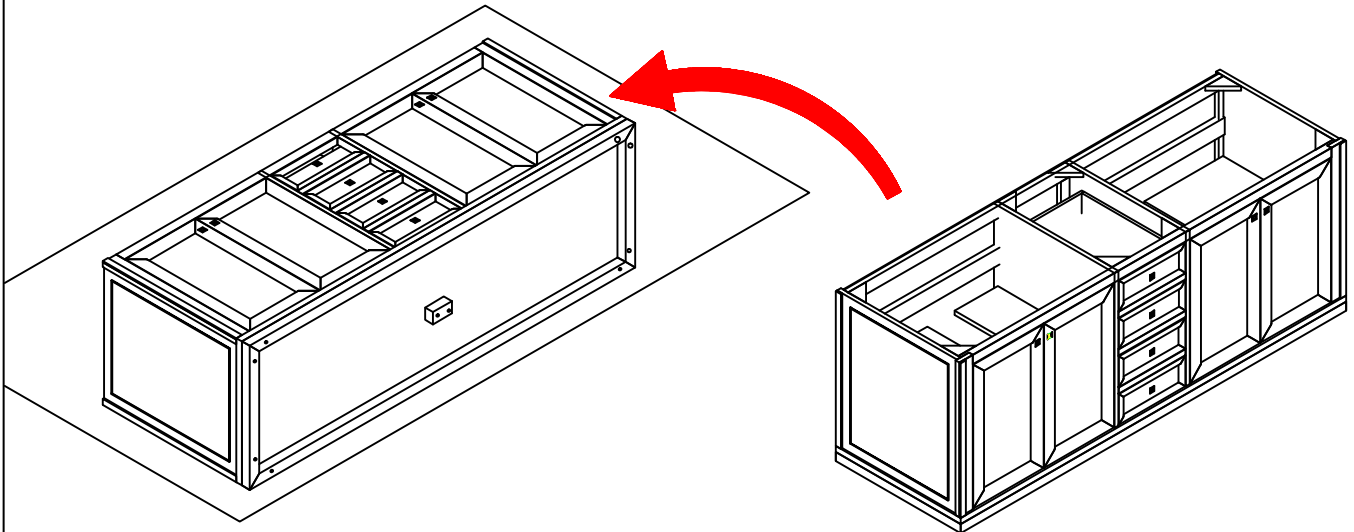

305-V72-WWW Vanity Assembly Instructions

IMPORTANT:

This product may be wall-mounted, or you may use the metal legs (included) for standard installation. If you wish to hang the cabinet on the wall, please read all pages very carefully. if you wish the cabinet sit on the floor, please read page 1 only.



Step 1:

To attach the legs, place the cabinet lay down on a blanket or similar soft material.

A=10PCS	ø5/16*3/4	
B=1PC	ø5	
C=10PCS	ø5/16	
D=10PCS	ø5/16*3/4	
E=4PCS	83*83*127	
J=1PCS	84*40*127	

Step 2:

Attach the Legs to the Cabinet, insert the bolt (A) through the Spring Washer (C), Flat Washer (D) through into the pre-drilled holes at the bottom of Cabinet, then tighten the bolts using by Allen Wrench.



305-V72-WWW Vanity Assembly Instructions

Tools required

Screw driver drill with 5/16" bit Pencil Measuring tape Screw driver Leveler Hammer

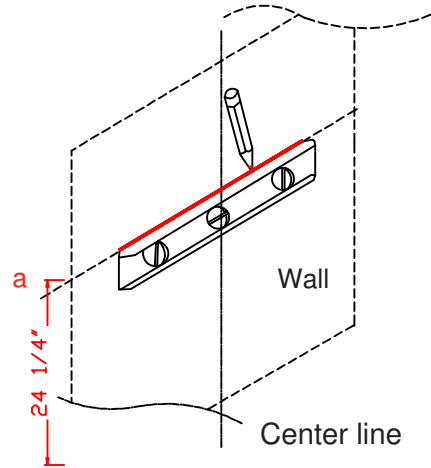
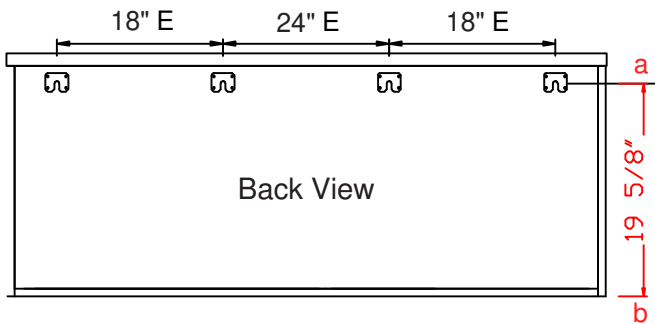
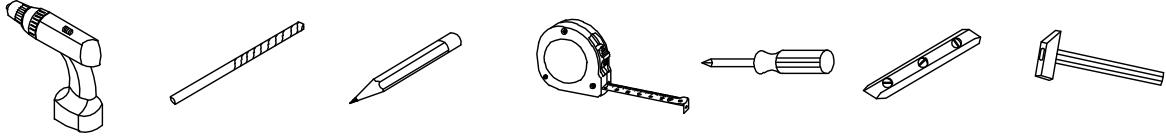

Step 1:
Metal plates has been pre-installed to the back of cabinet,
Measure the distance between the bottom of the cabinet
and point a.

Step 2:
Draw a horizontal line from the point a by using
a leveler.
(suggested H24 1/4" from floor to "a" line)

F=16PCS $\varnothing 8 \times 38$



G=4PCS 58*48*7



H=16PCS $\varnothing 4 \times 40$

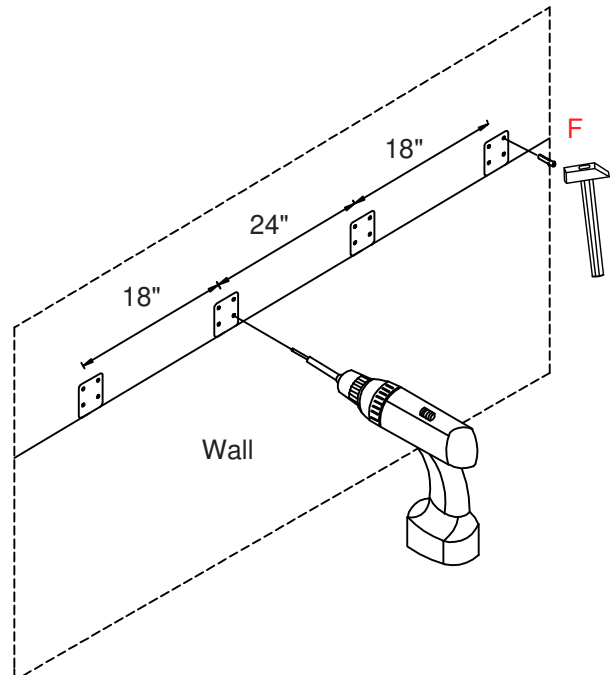
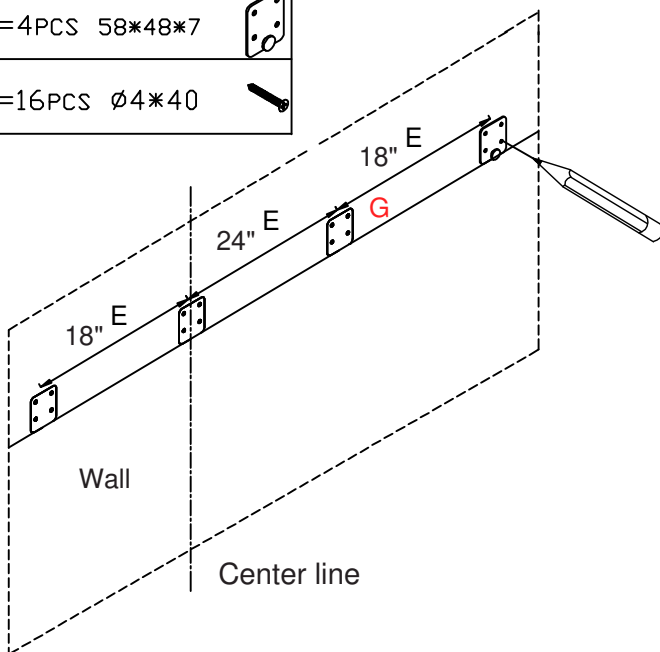

Step 3:
Draw the points according to the hole of the mounting
bracket

Step 4:
Drill the holes' depth no less than 40mm, and
insert "F" to the holes by using hammer.



305-V72-WWW Vanity
 Assembly Instructions

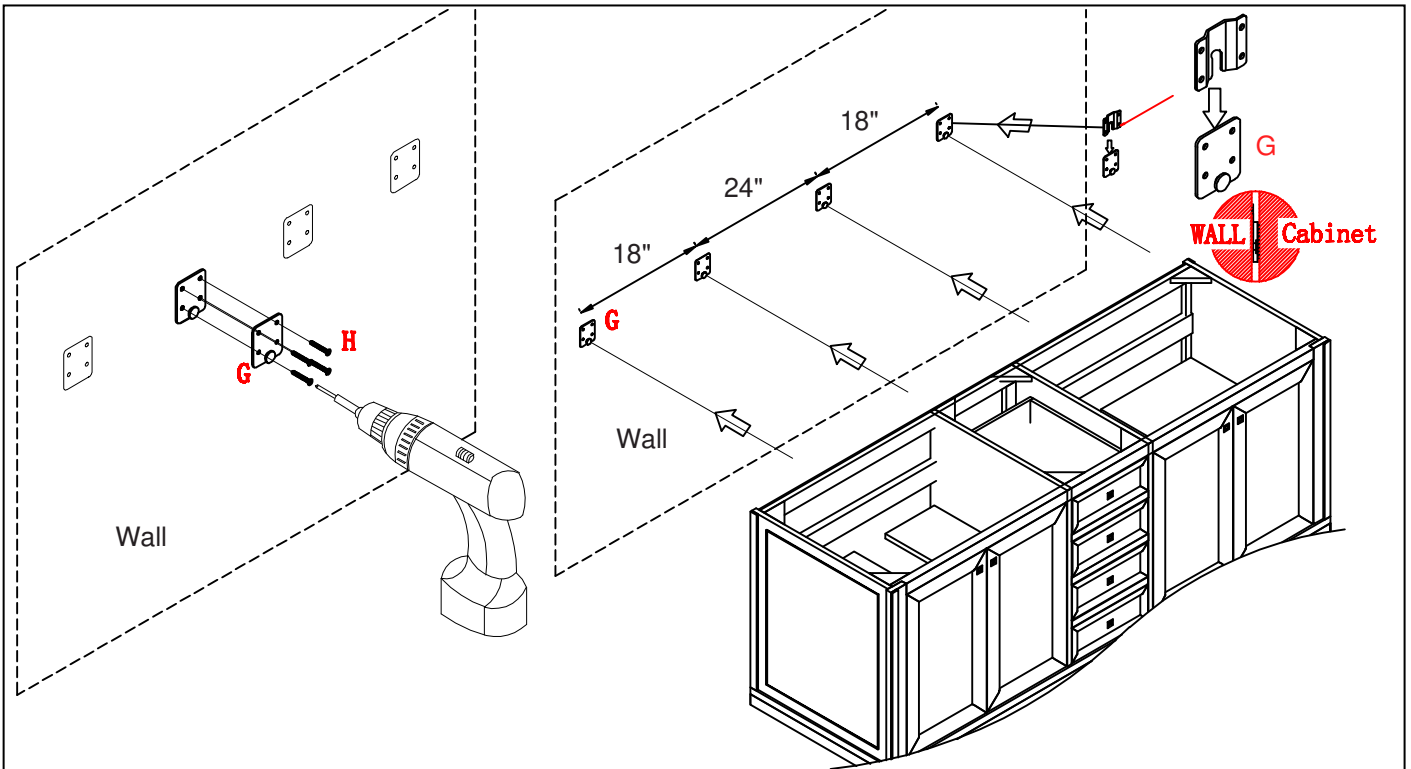

Step 5: Attach the mounting bracket to the wall.

Step 6: Hang the cabinet on the mounting bracket.

Note: Always use two or more people when hanging cabinet.

