

**MARSHALL  
71" CAST IRON  
DOUBLE  
SLIPPER TUB**

Cat. No.  
CTDSH



L: 71"  
W: 30 1/2"  
H: 30" (from floor to top of tub)  
22" (from floor to lowest tub rim)  
18 1/2" (from bottom of tub to top center of tub)  
26 3/4" (from bottom of tub to top of tub)

**Toe to Toe Measurements:**

35" Front to back  
20-1/2" Side to side



**The following is recommended for CTDSH tubs with deck holes:**

- Rim-mounted faucet: part #4601
- Straight bath supplies: part #5577
- Leg tub drain: part #5599

Gallon Capacity: 43 1/2  
Shipping Weight: 544 lbs.  
Empty Weight: 364 lbs.  
Filled Weight: 728 lbs.

**Features:**

- ▶ Inside finish is white enamel
- ▶ Lion feet available in 6 finishes
- ▶ Tub exterior is white
- ▶ Non-skid strips
- ▶ 7" deck holes in long side of tub
- ▶ Feet are attached and leveled before shipment
- ▶ Tub is thoroughly inspected before shipment
- ▶ Cast Iron base available: part# **CIDSB**

**Extra Paint Charge** (inside of tub is always white enamel):

**Bisque Paint** - \$160

**Black Paint** - \$160

Bathtubs painted in bisque or black are considered "special order" and are not returnable.

**Foot Finishes:**

**BP** Polished Brass

**SN** Brushed Nickel

**CP** Polished Chrome

**WH** White

**PN** Polished Nickel

**ORB** Oil-rubbed Bronze

Meets or exceeds the following specifications: A112-19-1M 1994.

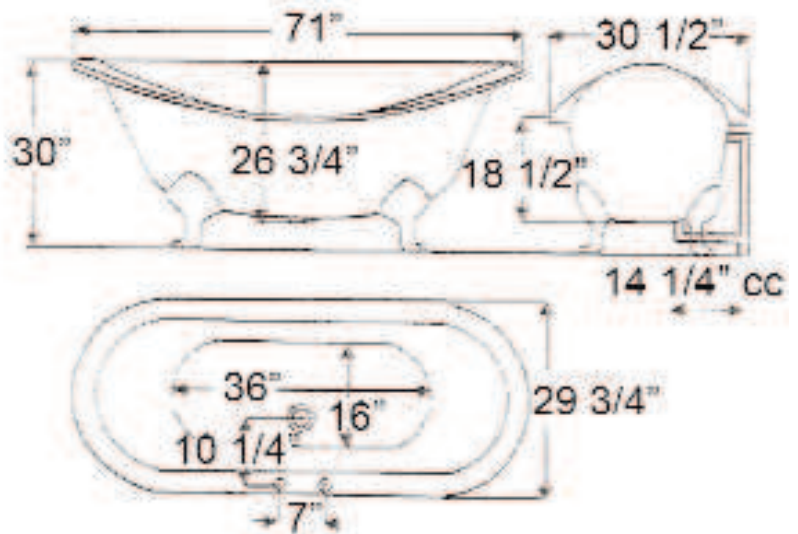

Dimensions of fixture are nominal and may vary within the range of tolerances established by ANSI Standard A112.19.2. Dimensions and specifications subject to change without notice.