

**LIVINGSTONE
68" ACRYLIC
SLIPPER TUB**

Cat. No.
ATSN68LP



L: 67 1/4"
W: 28 3/4"
H: 25 3/4" - 30 1/4"

Water depth: 17 1/2" to top of tub

The following is recommended for ATSN68LP tubs:

- Faucets: part #4602, 4022, and 4025
- Rigid, freestanding supplies: part #4502
- Leg tub drain: part #5599LT

Gallon Capacity: 57
Shipping Weight: 200 lbs.
Empty Weight: 150 lbs.
Filled Weight: 626 lbs.

Features:

- ▶ Acrylic construction for lighter weight
- ▶ Space between walls partially filled with fiberglass & resin
- ▶ Lion paw feet available in 4 finishes
- ▶ No faucet holes
- ▶ No overflow
- ▶ Tub feet are attached and leveled before shipment.
- ▶ Tub is thoroughly inspected before shipment

Feet Finishes:

BN Brushed Nickel **PB** Polished Brass
CP Polished Chrome **ORB** Oil Rubbed Bronze

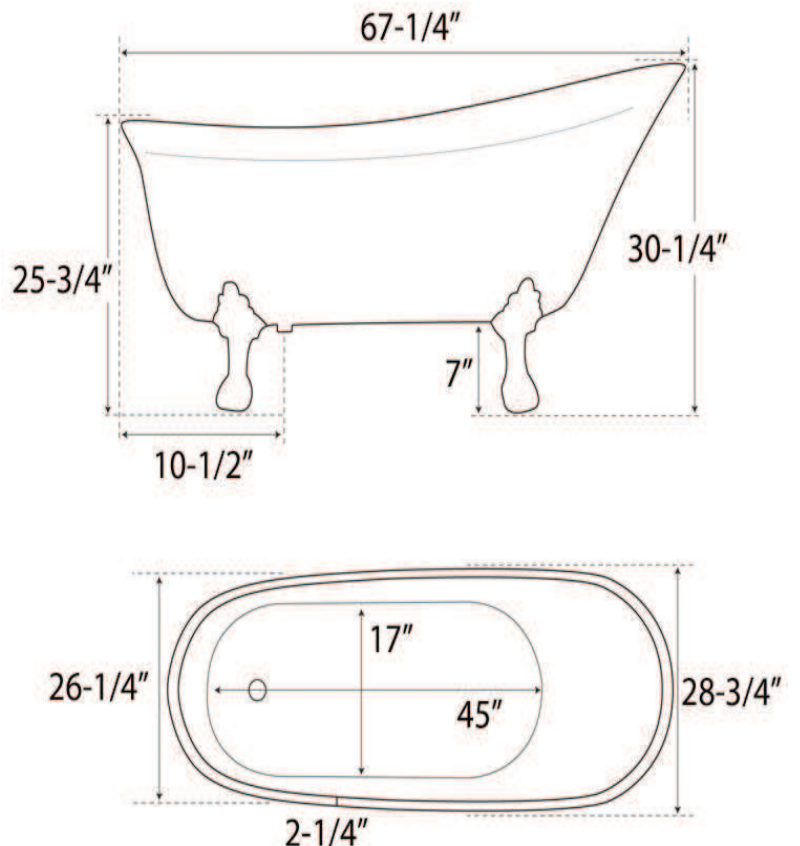

Dimensions of fixture are nominal and specifications subject to change without notice.