

**FOSTER
61" ACRYLIC
SLIPPER TUB**

Cat. No.
ATSN61LP



L: 61"
W: 27 1/2"
H: 24" - 30 1/2"

Water depth: 14 1/4" to overflow

The following is recommended for ATSN tubs:

- Faucets: part #4602
- Rigid, freestanding supplies: part #4502
- Leg tub drain: part #5599

Gallon Capacity: 39
Shipping Weight: 425 lbs.
Empty Weight: 200 lbs.
Filled Weight: 526 lbs.

Features:

- ▶ Acrylic construction for lighter weight
- ▶ Lion paw feet available in 4 finishes
- ▶ No faucet holes
- ▶ Tub feet are attached and leveled before shipment.
- ▶ Tub is thoroughly inspected before shipment

Feet Finishes:

BN Brushed Nickel **PB** Polished Brass
CP Polished Chrome **ORB** Oil Rubbed Bronze

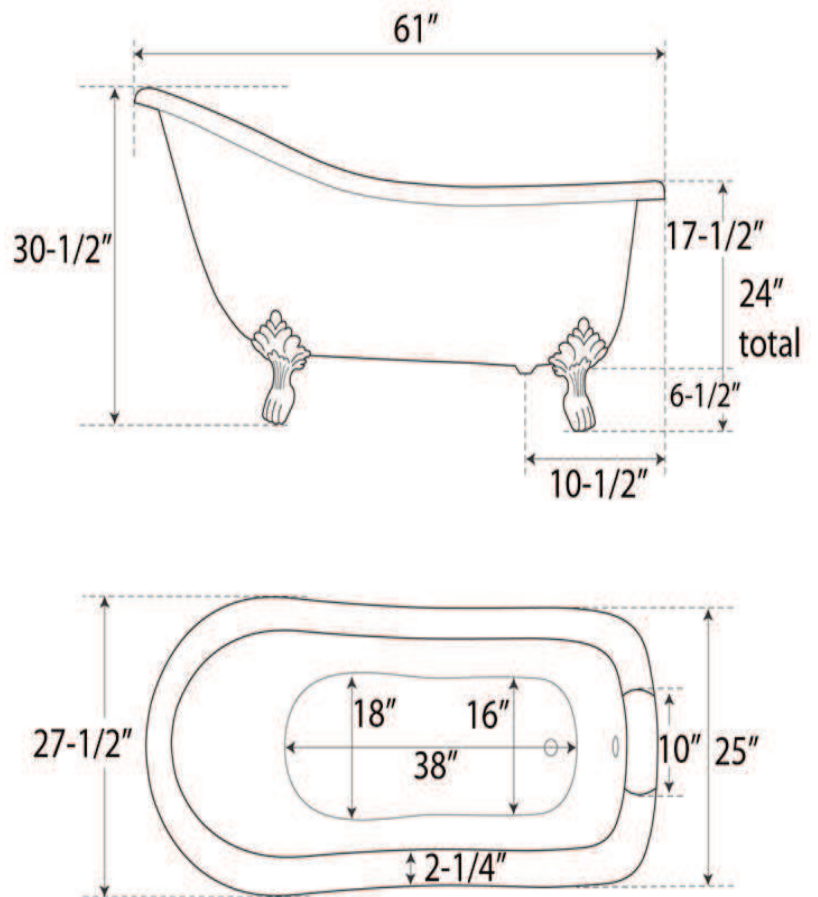

Dimensions of fixture are nominal and specifications subject to change without notice.