

# ESTELLE ACRYLIC SLIPPER TUB

Cat. No.  
ATS60



L: 60"  
W: 30"  
H: 21" (from floor) short end  
31" (from floor) tall end

**The following is recommended for  
ATS60 slipper tubs:**

- Faucets: part #4602, 7393 or 7410
- Use with Freestanding Bath Supplies:  
part #4502-PL
- Leg tub drain: part #5599

Gallon Capacity: 33  
Shipping Weight: 120 lbs.  
Empty Weight: 100 lbs.  
Filled Weight: 376 lbs.

All ATS60 tubs have no faucet holes.

## Features:

- ▶ Inside finish is either white or bisque to match outside color
- ▶ Ball and Claw Feet available in 8 finishes
- ▶ Outside is textured fiberglass reinforced polyester coated with two-part epoxy
- ▶ Feet are attached and leveled before shipment
- ▶ Tub is thoroughly inspected before shipment

## Tub Colors:

**WH** White  
**BQ** Bisque

## Foot Finishes:

<b>BP</b> Polished Brass	<b>PN</b> Polished Nickel
<b>CP</b> Polished Chrome	<b>BQ</b> Bisque
<b>BN</b> Brushed Nickel	<b>BL</b> Black
<b>ORB</b> Oil Rubbed Bronze	<b>WH</b> White

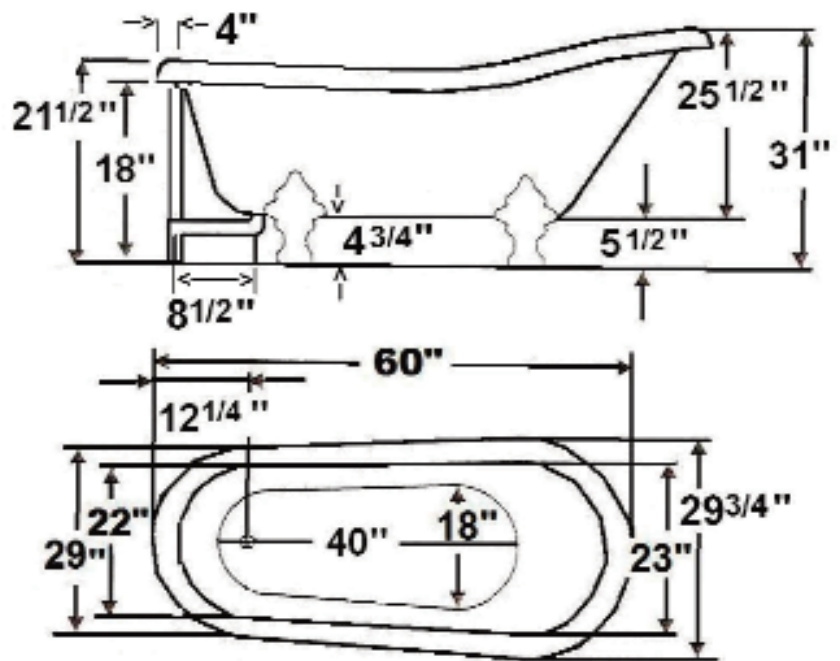

Dimensions of fixture are nominal and specifications subject to change without notice.