

**NOTTINGHAM
66" ACRYLIC
SLIPPER TUB**

Cat. No.
ATFSN66



L: 65 3/4"
W: 28 3/8"
H: 22 3/4"

Water depth: 17 1/2" to top of tub

The following is recommended for ATFSN66 tubs:
 •Faucets: part #7901 or 7913
 •Leg tub drain: part #5599LT

Gallon Capacity: 44
 Shipping Weight: 282 lbs.
 Empty Weight: 82 lbs.
 Filled Weight: 450 lbs.

Features:

- ▶ Interior and exterior walls acrylic sheets
- ▶ Air between sheets provides insulation to help retain warmth
- ▶ For use with a freestanding tub filler or faucet mounted on the wall
- ▶ No faucet holes
- ▶ No overflow
- ▶ Tub is thoroughly inspected before shipment

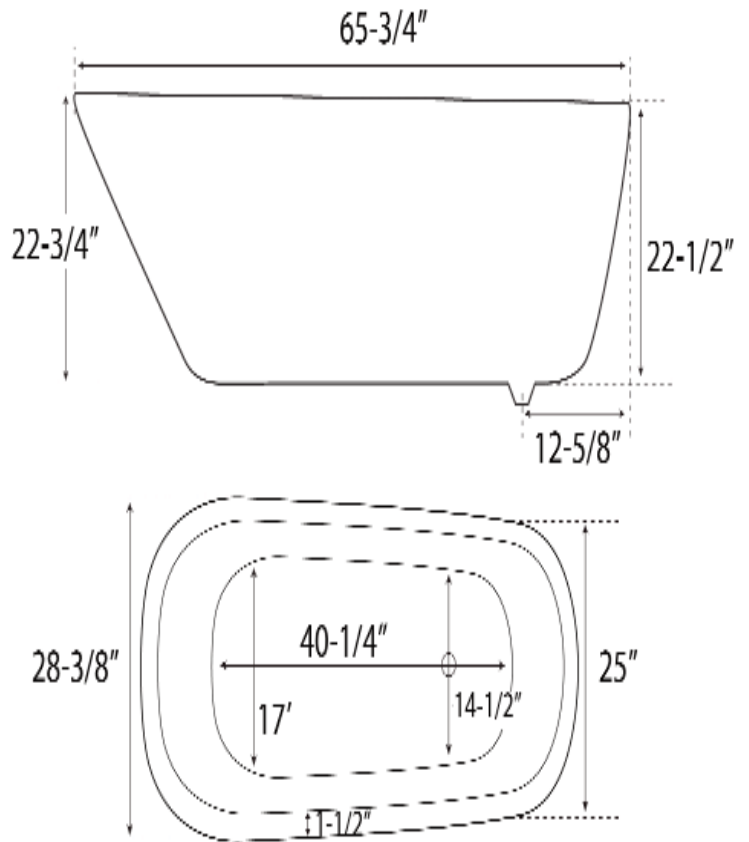

Dimensions of fixture are nominal and specifications subject to change without notice.