

**NORMANDY  
70" ACRYLIC DOUBLE  
SLIPPER TUB**

Cat. No.  
ATDSN70B



L: 69 1/2"  
W: 26 1/4"  
H: 26 1/2"

Water depth: 17" to top of tub

**The following is recommended for ATDSN70B tubs:**  
 •Faucets: part #7901 or 7913  
 •Leg tub drain: part #5599LT

Gallon Capacity: 55  
 Shipping Weight: 425 lbs.  
 Empty Weight: 200 lbs.  
 Filled Weight: 660 lbs.

**Features:**

- ▶ Interior and exterior walls acrylic sheets
- ▶ Space between walls partially filled with fiberglass & resin
- ▶ Petite base provides added flair
- ▶ For use with freestanding tub filler or faucet mounted on the wall
- ▶ No faucet holes
- ▶ No overflow
- ▶ Tub is thoroughly inspected before shipment

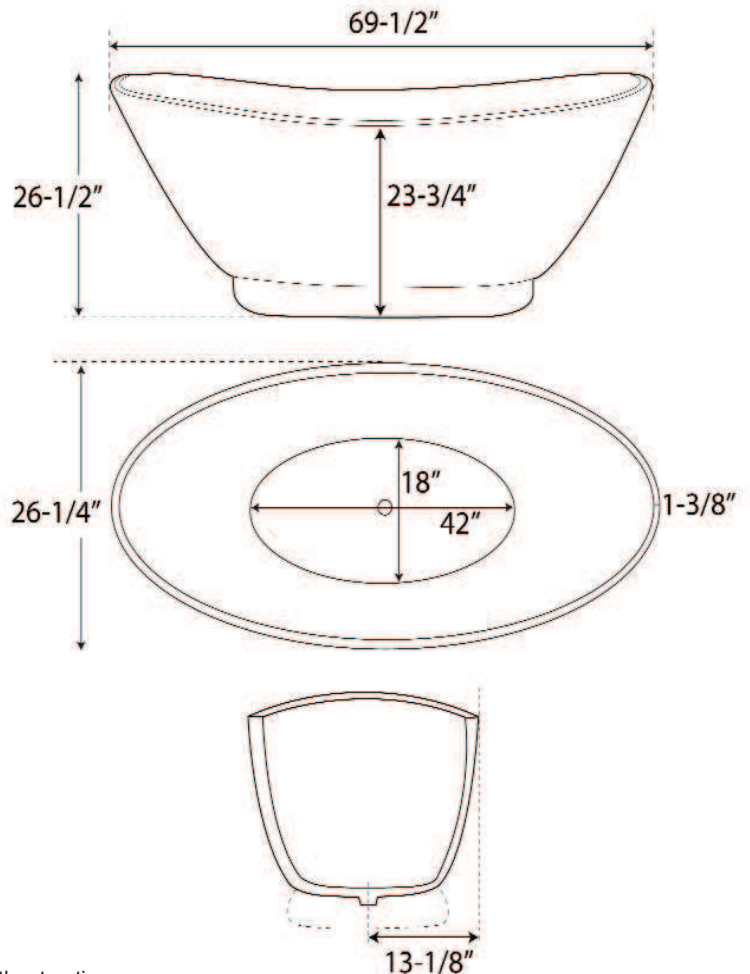

Dimensions of fixture are nominal and specifications subject to change without notice.