

**NEMO  
67" ACRYLIC DOUBLE  
SLIPPER TUB**

Cat. No.  
ATDSN67B



L: 67"  
W: 29 1/4"  
H: 27"

Water depth: 17 3/4" to top of tub

**The following is recommended for ATDSN67B tubs:**  
•Faucets: part #7082 or 7088  
•Rigid, freestanding supplies: part #4502  
•Leg tub drain: part #5599LT

Gallon Capacity: 61  
Shipping Weight: 425 lbs.  
Empty Weight: 200 lbs.  
Filled Weight: 709 lbs.

**Features:**

- ▶ Interior and exterior walls acrylic sheets
- ▶ Space between walls partially filled with fiberglass & resin
- ▶ For use with a freestanding tub filler or faucet mounted on the wall
- ▶ No faucet holes
- ▶ No overflow
- ▶ Tub is thoroughly inspected before shipment

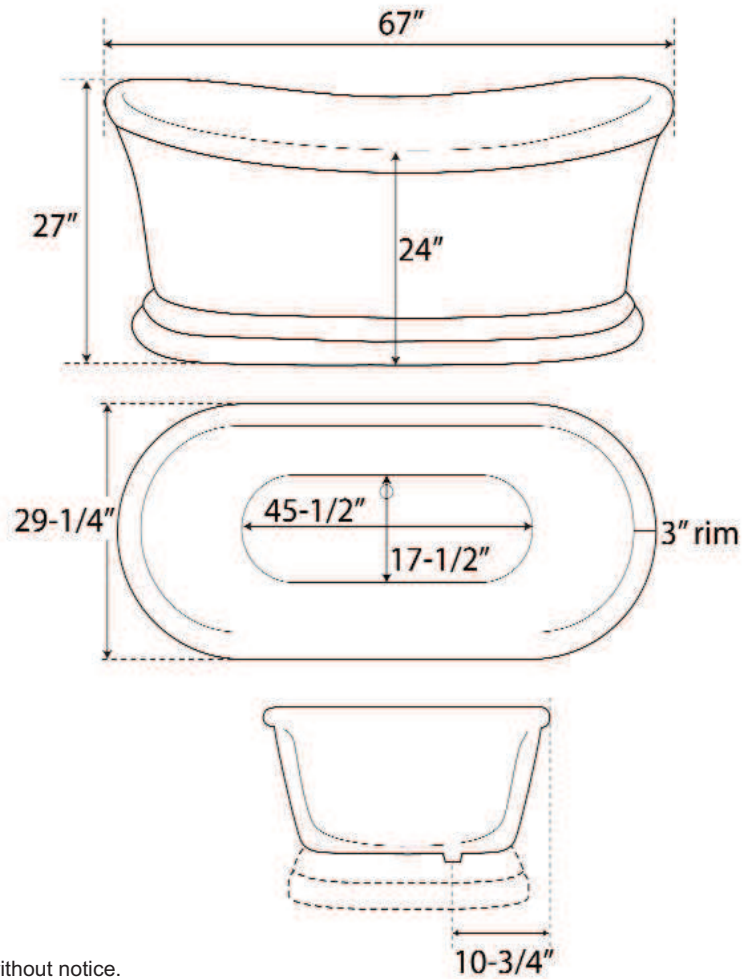

Dimensions of fixture are nominal and specifications subject to change without notice.